

Signet 2552 Metal Magmeter Flow Sensors



Features

- Test certificate included
- Award winning hot-tap magnetic flow sensor up to DN2550 (102 in.)
- Patented Magmeter technology*
- Operating range 0.05 to 10 m/s (0.15 to 33 ft/s)
- Reliable operation in harsh environments
- Repeatable: $\pm 0.5\%$ of reading @ 25 °C
- Three output options: 4 to 20 mA, Frequency/Digital (S³L)
- ISO or NPT Threads

Description

The Signet 2552 Metal Magmeter from Georg Fischer features all-stainless steel construction. The PVDF nosepiece and FPM O-rings are the only other wetted materials. The 2552 installs quickly into standard 1/4 in. or 1/2 in. pipe outlets, and is adjustable to fit pipes from DN50 to DN2550 (2 to 102 inches). Two sensor lengths allow maximum flexibility to accommodate a variety of hardware configurations, including ball valves for hot-tap installations.

When equipped with the frequency output, the 2552 is compatible with any externally powered Signet flow













instrument, while the digital (S³L) output enables multi-channel compatibility with the Signet 8900 Multi-Parameter Controller. Select the blind 4 to 20 mA current output to interface directly with dataloggers, PLCs or telemetry systems. Key features include Empty Pipe Detection, LED-assisted troubleshooting, and bi-directional span capability (in 4 to 20 mA models).

The Signet 3-0250 USB to Digital (S³L) Configuration/Diagnostic Tool is available to customize every performance feature in the 2552 so it can be adapted to the user's application requirements.

Applications

- Municipal Water Distribution
- Process and Coolant Flow
- Chemical Processing
- Waste Water
- Mining Applications
- Water Process Flow

System Overview

In-line Installation			
Panel Mount Signet Flow Instrument (sold separately) 5075 5500 5600 8550 8900 	Pipe, Tank, Wall Mount Signet 8550 Flow Instrument (sold separately)  Signet Universal Adapter Kit (3-8050) (sold separately) 	4 to 20 mA Input Chart Recorder OR Programmable Logic Controller  	
Signet 2552 Magmeter (standard or Hot-Tap) 			
for standard: ball or gate valve 1/4" or 1/2"		 	
for Hot-Tap: standard valve plus nipple 1/4" or 1/2"			
Weld-on weldolet 1/4" or 1/2" outlet 	Iron strap-on saddle 1/4" or 1/2" outlet 	Transition Saddles 1/4" or 1/2" outlet 	
Iron Multi-Saddle Plus 1/4" or 1/2" outlet 			



Dimensions

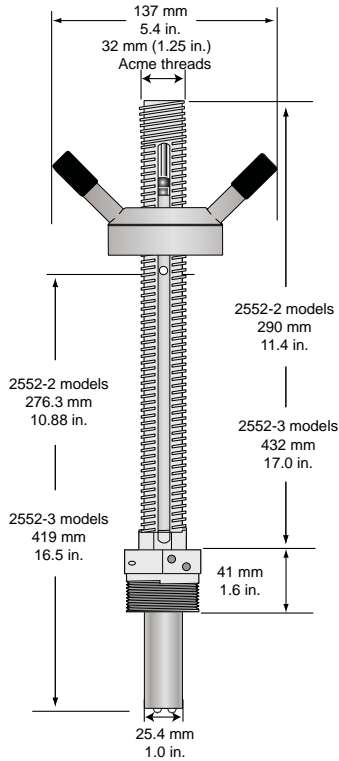

Specifications

General

Operating Range:

- Minimum: 0.05 m/s (0.15 ft/s)
- Maximum: 10 m/s (33 ft/s) for pipes to DN1200 (48 in.)
3 m/s (10 ft/s) for pipes over DN1200 (48 in.)

Pipe Size Range:

DN50 to DN2550 (2 in. to 102 in.)

Linearity: $\pm(1\% \text{ reading} + 0.01 \text{ m/s})$

$\pm(1\% \text{ reading} + 0.033 \text{ ft/s})$

Repeatability: $\pm 0.5\%$ of reading @ 25 °C

Accuracy: $\pm 2\%$ of measured value*

*[in reference conditions where the fluid is water at ambient temperature, the sensor is inserted at the correct depth and there is a fully developed flow profile which is in compliance with ISO 7145-1982 (BS 1042 section 2.2)]

Minimum Conductivity: 20 $\mu\text{S/cm}$

Wetted Materials

- 316L stainless steel body and electrodes
- PVDF Insulator
- O-rings: FPM (standard)
- Cable: 4-cond + shield, PVC jacket (Fixed cable models) or Water-resistant rubber cable assembly with Turck® NEMA 6P connector

Power Requirements

- 4 to 20 mA:
24 VDC $\pm 10\%$, regulated,
22.1 mA maximum
- Frequency:
5 to 24 VDC $\pm 10\%$, regulated,
15 mA maximum
- Digital (S³L):
5 to 6.5 VDC 15 mA maximum
- Reverse polarity and short circuit protected

Cable Options

- Fixed 7.6 m (25 ft) cable
- Detachable water tight sensor cable with Turck® connector sold separately, two lengths: 4 m (13 ft) or 6 m (19.5 ft)

Electrical

Current Output (4 to 20 mA)

- Programmable and reversible
- Loop Accuracy:
32 μA max. error (@ 25 °C @ 24 VDC)
- Temp. Drift: $\pm 1 \mu\text{A}$ per °C max.
- Power Supply Rejection: $\pm 1 \mu\text{A}$ per V
- Isolation: Low voltage < 48 VAC/DC from electrodes and auxiliary power
- Maximum Cable: 300 m (1000 ft)
- Max. Loop Resistance: 300 Ω
- Error Condition: 22.1 mA

Electrical (continued)

Frequency Output:

- Compatible with Signet 5075, 5500, 5600, 8550 and 8900
- Max. Pull-up Voltage: 30 VDC
- Short Circuit Protected:
 $\leq 30 \text{ V @ } 0 \Omega$ pull-up for one hour
- Reverse Polarity Protected to -40 V for 1 hour
- Overvoltage Protected to +40 V for 1 hour
- Max. Current Sink:
50 mA, current limited
- Maximum cable: 300 m (1,000 ft)

Digital (S³L) Output:

- Compatible with Signet 8900
- Serial ASCII, TTL level 9600 bps
- Maximum Cable: Application dependent (See 8900 manual)

Max. Temperature/Pressure Rating

Storage Temperature:

-15 °C to 70 °C (5 °F to 158 °F)
in non-icing conditions

Operating Temperature

- Ambient:
-15 °C to 70 °C (5 °F to 158 °F)
in non-icing conditions
- Media:
-15 °C to 85 °C (5 °F to 185 °F)

Maximum Operating Pressure

20.7 bar @ 25 °C (300 psi @ 77 °F)

Hot-Tap Installation Requirements

- Maximum Installation Pressure:
20.7 bar (300 psi)
- Maximum Installation Temp (Insertion/Removal):
40 °C (104 °F)

Do not use hot-tap installation where temperatures will exceed 40 °C or if hazardous liquids are present.

Standards and Approvals

- CE
- RoHS compliant
- U.S. Patent No.: 7,055,396 B1
- NEMA 4 (IP65) (fixed cable models)
- NEMA 6P (IP68) (Submersible cable models only)
Signet recommends maximum 3 m (10 ft) submersion depth for maximum 10 days continuous submersion.
- Manufactured under ISO 9001 for Quality and ISO 14001 for Environmental Management

Sensor Selection Guide

The 2552 Magmeter can be installed into a variety of pipe sizes. Follow the steps below to ensure that you choose the right sensor for your application.

Step 1: Determine how the sensor will be installed

A. For standard (non Hot-Tap) installations:

The height of the weldolet (threadolet) and pipe adapter(s) should be determined before the sensor is purchased.

- For retrofit installations, the stack height, or "A" dimension (see Fig. 1), is the overall height from the top of the pipe to the highest point of the stack.
- Sensor tip must be positioned at 10% of pipe ID
- For new installations, Signet recommends a weldolet (threadolet) and an adapter to accommodate the 1¼ in. (or 1½ in. for 2552-3) sensor process threads. The stack height, or "A" dimension (see Fig. 1), is the overall height from the top of the pipe to the highest point of the stack before the sensor is connected

B. For Hot-Tap installations:

The stack height of the ball valve, nipple weldolet (threadolet) and pipe adapters should be determined before the sensor is purchased.

- For retrofit installations, the ball valve must be at least a 1¼ in. (or 1½ in. for 2552-3) valve. The stack height, or "A" dimension (see Fig. 2), is the overall height from the top of the pipe to the top of the ball valve.
- Sensor tip base must be positioned at 10% of pipe ID
- For new installations, Signet recommends a 1¼ in. or 1½ in. full port ball valve, a short nipple and a weldolet (threadolet). The stack height or "A" dimension (see Fig. 2) is the overall height from the top of the pipe to the top of the ball valve before the sensor is connected.

Step 2: Determine how the sensor will be installed

Once the "A" dimension is determined, go to the sensor selection table and find your "A" dimension on the left column. Next, find the appropriate pipe size at the top of the chart. To determine the correct sensor size locate where the pipe size column meets the max "A" dimension row.

		Pipe Size																										
		DN	50	65	80 to 90	100	125	150 to 200	250	300 to 350	400	450	500	600	650 to 700	750 to 800	850	900 to 950	1000 to 1100	1200	1400	1500	1700	1800	2000	2100	2288 m	
Max. "A" Dim	mm	inches	2	2	2	2	2	2	2	2	2	2	2	2	2	2	2	2	2	2	2	2	2	2	2	2	2	2
	50.8	2	2	2	2	2	2	2	2	2	2	2	2	2	2	2	2	2	2	2	2	2	2	2	2	2	2	2
	63.5	2.5	2	2	2	2	2	2	2	2	2	2	2	2	2	2	2	2	2	2	2	2	2	2	2	2	2	2
	76.2	3	2	2	2	2	2	2	2	2	2	2	2	2	2	2	2	2	2	2	2	2	2	2	2	2	2	2
	88.9	3.5	2	2	2	2	2	2	2	2	2	2	2	2	2	2	2	2	2	2	2	2	2	2	2	2	2	2
	101.6	4	2	2	2	2	2	2	2	2	2	2	2	2	2	2	2	2	2	2	2	2	2	2	2	2	2	2
	114.3	4.5	2	2	2	2	2	2	2	2	2	2	2	2	2	2	2	2	2	2	2	2	2	2	2	2	2	2
	127	5	2	2	2	2	2	2	2	2	2	2	2	2	2	2	2	2	2	2	2	2	2	2	2	2	2	2
	139.7	5.5	2	2	2	2	2	2	2	2	2	2	2	2	2	2	2	2	2	2	2	2	2	2	2	2	2	2
	152.4	6	2	2	2	2	2	2	2	2	2	2	2	2	2	2	2	2	2	2	2	2	2	2	2	2	2	2
	165.1	6.5	2	2	2	2	2	2	2	2	2	2	2	2	2	2	2	2	2	2	2	2	2	2	2	2	2	2
	177.8	7	2	2	2	2	2	2	2	2	2	2	2	2	2	2	2	2	2	2	2	2	2	2	2	2	2	2
	190.5	7.5	2	2	2	2	2	2	2	2	2	2	2	2	2	2	2	2	2	2	2	2	2	2	2	2	2	2
	228.6	9	2	2	2	2	2	2	2	2	2	2	2	2	2	2	2	2	2	2	2	2	2	2	2	2	2	2
	241.3	9.5	3	3	3	3	3	3	3	3	3	3	3	3	3	3	3	3	3	3	3	3	3	3	3	3	3	3
	254	10	3	3	3	3	3	3	3	3	3	3	3	3	3	3	3	3	3	3	3	3	3	3	3	3	3	3
	266.7	10.5	3	3	3	3	3	3	3	3	3	3	3	3	3	3	3	3	3	3	3	3	3	3	3	3	3	3
279.4	11	3	3	3	3	3	3	3	3	3	3	3	3	3	3	3	3	3	3	3	3	3	3	3	3	3	3	
292.1	11.5	3	3	3	3	3	3	3	3	3	3	3	3	3	3	3	3	3	3	3	3	3	3	3	3	3	3	
304.8	12	3	3	3	3	3	3	3	3	3	3	3	3	3	3	3	3	3	3	3	3	3	3	3	3	3	3	
317.5	12.5	3	3	3	3	3	3	3	3	3	3	3	3	3	3	3	3	3	3	3	3	3	3	3	3	3	3	
330.2	13	3	3	3	3	3	3	3	3	3	3	3	3	3	3	3	3	3	3	3	3	3	3	3	3	3	3	
342.9	13.5	3	3	3	3	3	3	3	3	3	3	3	3	3	3	3	3	3	3	3	3	3	3	3	3	3	3	
355.6	14	3	3	3	3	3	3	3	3	3	3	3	3	3	3	3	3	3	3	3	3	3	3	3	3	3	3	
375.9	14.8	3	3	3	3	3	3	3	3	3	3	3	3	3	3	3	3	3	3	3	3	3	3	3	3	3	3	
381	15																											

This chart is based on the thickest commonly available pipe.

Step 3: Refer to Ordering Information to select corresponding part numbers

Fig. 1
Standard installation with "A" dimension using a weldolet (threadolet)

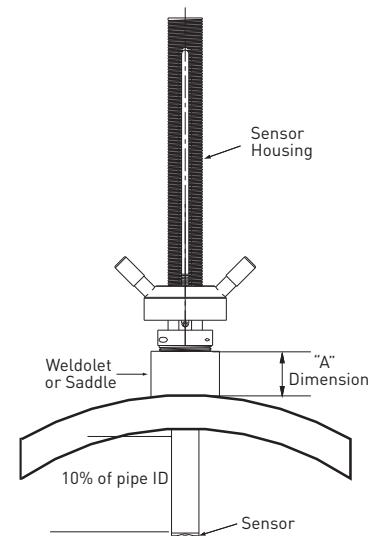
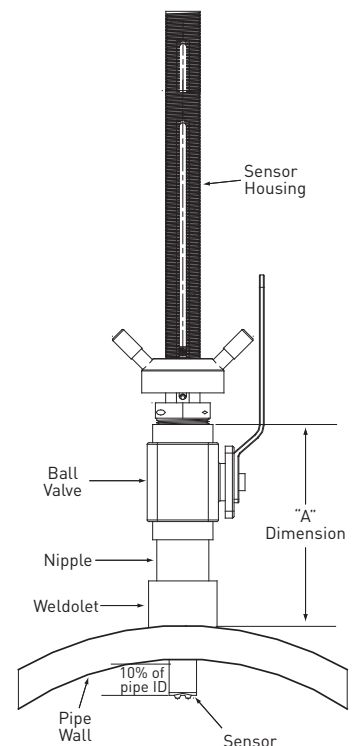

Fig. 2
Hot-Tap installation with "A" dimension using a ball valve, short nipple and weldolet (threadolet)



Legend:

- Use 3-2552-2, max. insertion = 236 mm (9.3 in.)
- Use 3-2552-3 max. insertion = 368 mm (14.8 in.)

Model 2552

Ordering Notes

- 1) Sensor insertion depth is the distance from the bottom of the sensor housing to the tip of the sensor.
- 2) Hot-Tap installations require a 1¼ in. or 1½ in. ball valve.
- 3) See Sensor Selection Guide on previous page to determine the sensor length required.

Application Tips

- Minimum process liquid conductivity requirement is 20 µS/cm.
- 1½ x 1¼ inch and 2 x 1¼ inch (2552-2 only) retrofit adapters are available for replacement installations of Signet 2550 and 2540 sensors.

Ordering Information

Model 2552 Metal Magmeter Ordering Matrix					
3-2552	Mounting Depth Options - Choose One*				
	-2	Sensor insertion depth = 9.3 inches*			
	-3	Sensor insertion depth = 14.8 inches*			
	Process Connection Options - Choose One				
	1	1¼ inch NPT process connection threads**			
	2	1¼ inch ISO process connection threads**			
	3	1½ inch (2552-3 only) NPT process connection threads**			
	4	1½ inch (2552-3 only) ISO process connection threads**			
	Cable and Connector Options - Choose One				
	-A	Fixed Cable, 7.6 m (25 ft); no connector			
	-B	Watertight sensor connector; cable sold separately			
	Output Options - Choose One				
	-11	Frequency or Digital (S ³ L); for use with any Signet Flow Instrument or the 8900 Multi-Parameter Controller			
	-12	4 to 20 mA output			
	↓				
3-2552	-1	1	-A	-12	Example Part Number

* Customer must determine stack height (ball valve, nipple, weldolet, etc.). Refer to Sensor Selection on previous page to determine "A" dimension. Sensor tip must be positioned at 10% of pipe ID.

** 1¼ inch process connection is the standard thread size on the 3-2552-2X-X-XX: For the 2552-3 the 1½ inch process connection is standard and the 1¼ inch is available as a special order.

Mfr. Part No.	Code	Mfr. Part No.	Code
3-2552-21-A-11	159 001 513	3-2552-33-A-11	159 001 521
3-2552-21-A-12	159 001 514	3-2552-33-A-12	159 001 525
3-2552-21-B-11	159 001 515	3-2552-33-B-11	159 001 523
3-2552-21-B-12	159 001 516	3-2552-33-B-12	159 001 527
3-2552-22-A-11	159 001 517	3-2552-34-A-11	159 001 522
3-2552-22-A-12	159 001 518	3-2552-34-A-12	159 001 526
3-2552-22-B-11	159 001 519	3-2552-34-B-11	159 001 524
3-2552-22-B-12	159 001 520	3-2552-34-B-12	159 001 528

Accessories and Replacement Parts

Mfr. Part No.	Code	Description
2120-1512	159 001 425	1½ x 1¼ inch NPT adapter for retrofitting 2540 installation to 2552 - 316 SS
2120-2012	159 001 426	2 x 1¼ inch NPT adapter for retrofitting 2550 installation to 2552 - 316 SS
3-2552.392	159 001 530	1¼ inch NPT full port stainless steel ball valve and nipple kit
3-2552.393	159 001 531	1¼ inch NPT full port brass ball valve & nipple kit
3-2552.394	159 001 532	1½ inch NPT conduit adapter, aluminum for -1 and -2 units
4301-2125	159 001 533	1¼ inch NPT full port ball valve - brass
4301-3125	159 001 387	1¼ inch NPT full port ball valve - stainless steel
5541-4184	159 001 388	4-conductor, 22 AWG, water-tight connector, 4 m (13 ft)
5541-4186	159 001 389	4-conductor, 22 AWG, water-tight connector, 6 m (19.5 ft)
special order	special order	4-conductor, 22 AWG, water-tight connector, cable length in 25 ft increments
special order	special order	1¼ in. NPT or ISO process connection threads to replace 1½ in. NPT or ISO threads
3-0250	159 001 538	USB to Digital (S ³ L) Configuration/Diagnostic tool

