

Hygienic Type Turbine Flowmeter

The BNO series flowmeters have been designed specifically for high accuracy flow measurement and batch control in the liquid food industries, and conforms to the same exacting standards as our NT industrial flowmeters so far as performance is concerned.

In the basic design, icenta CONTROLS has been aware of the particular hygienic requirements of the brewing and dairy industries, and great care has been taken to ensure the absence of crevices where bacteria can lodge and breed.

The materials used in construction ensure that no corrosive attack occurs when in-place cleaning agents are used.

Manufactured entirely from stainless steel, except the bearing bushes which are normally of PTFE/Carbon. There are no seals or 'O' rings, nor any internal screw threads. Rotors are machined from the solid, and bearing supports (hangers) are stepped in order to reduce the contact area between hanger and meter internal bore.

Operating principle

A ferritic stainless steel rotor revolves within a nonmagnetic housing on the outside of which is located a pick off coil containing a permanent magnet. As the rotor blades pass the tip of the permanent magnet, the reluctance of the magnetic circuit is changed, and a small a.c. voltage is generated in the coil. The frequency of the a.c. voltage is proportional to flowrate, and the total number of pulses produced represents total flow passed through the meter.

The flowmeter may be located some considerable distance from the associated secondary instrument, and remote flow rate indication, total flow, and most important remote batch control are thus possible.

Advantages

- Minimum of bacteria breeding crevices
- Simple robust design
- Easy one circlip dismantling
- Strong rotor design
- Long bearing life
- Steam cleaning permissible
- Hot detergent Sterilizing permissible
- Excellent repeatability for batching
- Wide variety of end fittings available

A range of electronic readout instruments have been designed to complement our range of turbine flowmeters. Information is available on pages 13-16.



Installation and use

For best results the flowmeter should be installed well away from heavy current carrying cables and with control valves etc. located downstream of the meter.

A length of straight pipe of bore equal to the meter inlet should be provided, preferably 10 diameters in length, and if possible containing flow straightening vanes at the inlet end. Turbine meters are sensitive to swirl and any pipe swirl present upstream may cause a change in meter factor.

Strainers should be provided to minimise the risk of damage due to small solids in suspension. Meters maybe installed in any attitude but the flow direction and mounting attitude should be advised at the order stage if other than horizontal.

All flowmeters are calibrated on water at our test facility before despatch and a calibration certificate issued.

Full instructions concerning the electrical connections and signal cables are supplied with the handbook for the particular electronic readout equipment being supplied, but it is important to remember that the signal cable screen should be earthed at one point only in the system to avoid earth loops.

Pick off coils should be screwed down to the bottom of the coil well but should not be tightened by spanner.

Operating pressures are in most cases limited by the type of end fittings, and meters have been supplied to operate up to 350 bar.

Varying densities have no appreciable affect on the accuracy of axial flow turbine meters so far as volumetric flow is concerned. If readout is required in mass flow terms we can supply density or temperature compensation equipment to automatically correct for density variation. All turbine meters are to some extent sensitive to viscosity changes and any likely viscosity variation should be advised at the order stage. High viscosity and/or low density will tend to reduce the operating flow range over which the meter will yield the stated linearity.

Care should be taken to avoid cavitation at the meter and a good general rule is to ensure that the static pressure downstream is equal to at least twice the pressure drop across the flowmeter plus the vapour pressure of the fluid.

Temperatures up to 150°C are permissible using our standard pick off coil.

Servicing may be carried out by our service engineers in the field, but meters should be returned to our factory wherever possible for repair.

Bearing replacement can be effected on site by any skilled fitter and instructions will be provided on request.

When requesting service visits or spares the full serial number should be stated, which immediately gives us access to the original order files for the installation.

Sizing table

Type Number	Flow Range (Linear)		Approx. K Factor		Linearity	Pressure Drop (Bar) at max. flow	Overall Length	End Fittings Type		
	ltrs/min	I.G.P.M.	ltrs	Imp. Gall.				RJT	ISS	Tri-clamp
BNO250	2.0-20	.4-4	3000	13600	±0.5%	.22	127	1"	1"	1/2"
BNO500	9.0-90	2-20	1000	4550	±0.5%	.22	162	1"	1"	1"
BNO1000	18-180	4-40	330	1500	±0.5%	.22	162	1"	1"	1"
BNO1500	25-250	6-55	240	1090	±0.5%	.20	162	1 1/2"	1 1/2"	1"
BNO2000	45-450	10-100	100	454	±0.5%	.25	155	2"	2"	1 1/2"
BNO36	65-650	14-140	90	400	±0.5%	.30	155	2"	2"	1 1/2"
BNO50	90-900	19-190	33	150	±0.5%	.30	165	2"	2"	2"
BNO65	120-1200	26-260	17	78	±0.5%	.30	216	3"	3"	3"

The flow ranges given assume a liquid with viscosity 1 cps and s.g. of 1.0. Increase in viscosity increases the minimum linear flowrate such that overall linear range is reduced. For increased viscosities refer to Head Office. The pressure drop figures given assume a viscosity of 1 cps and are the maximum estimated figures for

maximum flowrate for the given meter size. For lower flowrates the pressure drop reduces as the square of the flowrate. The performance figures given above are based on previous experience and are what we would expect to achieve on calibration. No guarantee is however given unless specifically agreed at the order stage.

Dimensions

Type Number	A	B	C
BNO 250	80	50	70
BNO 500	162	50	75
BNO 1000	162	50	78
BNO 1500	162	50	80
BNO 2000	155	70	82
BNO 36	155	64	85
BNO 50	165	75	92
BNO 65	216	96	98

Allow an extra 50mm height on dimension C for pick off coil connector.

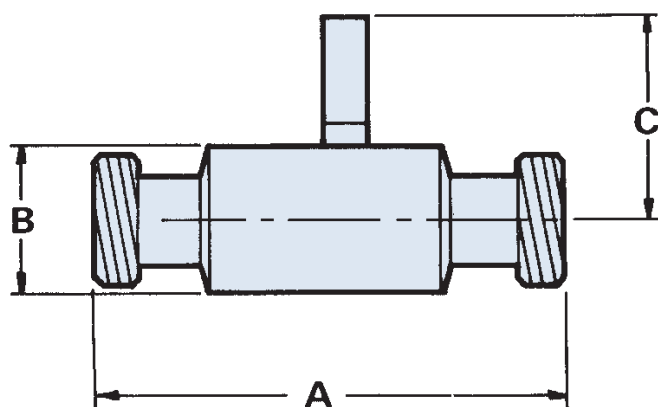

Parts and materials

1	Circlip	302 st/stl
2	Downstream Hanger	316 st/stl
3	Rotor with bush	431 st/stl PTFE/Carbon
4	Spindle	316 st/stl
5	Upstream Hanger	316 st/stl
6	Housing	316 st/stl
7	Coil collar	316 st/stl
8	Pick off coil	st/stl body

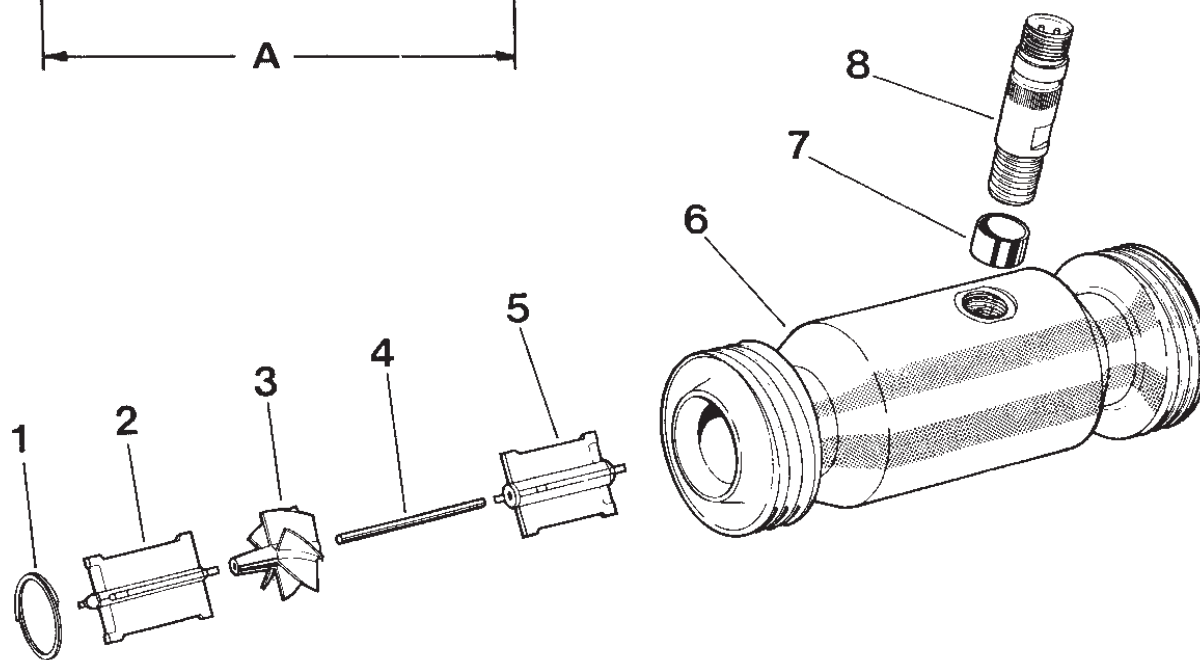

Technical data

Measuring range	10-1
Accuracy	±0.5%
Repeatability	±0.1%
Flow ranges	min. 2-20 l/min max. 120-1200 l/min
Maximum operating temperature	150°C
Maximum operating pressure	Limited only by coupling design
Transmission length	Up to 300 mtrs. without pre-amp
Pick off coil	Reluctance type with amphenol connector for miniature screened cable. I.S. version available for hazardous locations

The BNO range of turbine meters have been particularly successful in the brewing industry where thousands of units are employed throughout Britain and abroad in keg filling operations. Several leading breweries have standardised on the BNO design to ensure high accuracy batching and long maintenance free operation. icenta CONTROLS offer a flexible approach to design and end fittings such as RJT and tri clamp hygienic couplings can be supplied without any penalty in cost and delivery. Special designs have been considered for unusual applications e.g. wine bag filling, where a heavy duty design was employed to cope with continuous repetition of very small batches.



1" tri clamp fittings



1" CB/TS two start

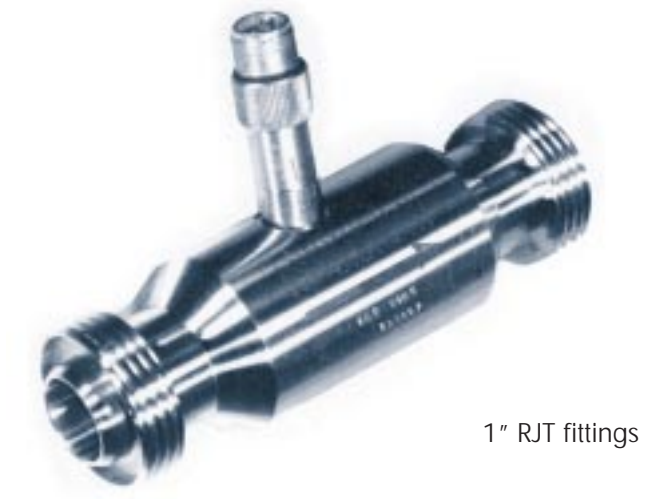

1" RJT fittings