



## Inexpensive Microflow Coriolis Flowmeter

# CoriMate II

MODEL:CR002, CR003, CR004

**GENERAL SPECIFICATION**  
**GS.No.GBN064E-1**

## ■ GENERAL

Based on the knowledge and experience on Coriolis technologies OVAL has gained over many years, the Corimate is a compactly built Coriolis flowmeter integral with a transmitter and display. It is characterized by competitive price, outstanding performance, user friendliness, and operating safety to most effectively meet customer needs. It has expanded the range of precise metering at extreme low flow rates and the size of non-explosionproof instruments market.

## ■ FEATURES

1. Low priced Coriolis flowmeter series.
2. Single case construction with built-in probe and transmitter (with display).
3. Vibration-proof base not required.
4. Simple installation and easy to use.
5. Wetted parts material: SUS316L
6. Flow range: 2.5 to 2700 g/min in three types.
7. CE-Marking conformity product.

## ■ TYPICAL APPLICATIONS

1. The mass flow measurement.
2. Multiple liquid measurements with a study, experiment facilities.
3. Medicinal solution, solution process.
4. Slurry liquid, mixture process.
5. Paint, spray, additive applications.

## ■ GENERAL SPECIFICATIONS

Item	Description		
Model	CR002	CR003	CR004
Nominal Size	0.7mm	1.5mm	3mm
Materials	Wetted parts	SUS316 (*1)	
	Base	SUS304	
	Housing and cover	ADC12	
	Display shield	Polycarbonate	
Process connection	Rc 1/8		
Acceptable fluid	Liquid (Density range : 0.3 to 2.0g/mL)		
Operating temp. range	-10 to +60°C (Free of dew condensation)		
Max. operating pressure	2MPa		
Flow directions	Forward flow only		
Power supply (*2)	20 to 30VDC		
Power consumption	Max. 10W		
Furnished cable	AWG24×7-conductor, φ6.8×3m		
Dustproof, waterproof construction	IP66		
Installation	<ul style="list-style-type: none"> <li>• Horizontal installation (clamp not required)</li> <li>• Vertical installation (optional bracket available)</li> </ul>		
Display	Backlit dot matrix : 8 digits		
Variables displayed	Instant mass flow, mass flow total, temperature		
Weight	Approx. 6kg		
Communication interface	Bell 202 (using the HART protocol)		
Pulse output (*3)	Mass flow total open collector output (30V, 50mADC max.) FS: 0.1 to 10000Hz selectable • CR002 : 0.01g/P at 125Hz • CR003 : 0.01g/P at 500Hz • CR004 : 0.1g/P at 450Hz		
Analog output (*3)	4 to 20mADC Max. load 600Ω Instant mass flowrate Damping: 1 sec. (std.) • CR002 : 0 to 75g/min • CR003 : 0 to 300g/min • CR004 : 0 to 2700g/min		
Applicable EU directive	EMC directive : 2004/108/EC		

(\*1): Corrosion resistance of nickel brazing used in wetted parts is equivalent to SUS314.

(\*2): SU1503 power unit is not acceptable to this meter.

(\*3): The pulse output at the time of the shipment and analog output are standard setting. (The setting change is possible)



# OVAL Corporation

<http://www.oval.co.jp>

Head Office (Tokyo): Phone. 81-3-3360-5121. Fax. 81-3-3365-8605  
 Beijing Office: Phone. 86-10-5867-4711. Fax. 86-10-5867-4713  
 Overseas Branch Offices: Seoul, Singapore and Taipei

■ GENERAL PERFORMANCE

Item	Description			
	Model	CR002	CR003	CR004
Flowrate (Liquid)	Max. Flowrate g/min	75	300	2700
	Min. Analog range g/min	5	20	180
	Cutoff g/min (※1)	1.5	6	54
	Factory calibration accuracy	±0.1% of F.S. (Below 33% of flowrate) ±0.3% RD (33% to 100% of flowrate)		
	Repeatability	±0.07% of F.S. (Below 33% of flowrate) ±0.2% RD (33% to 100% of flowrate)		
	Analog accuracy	Accuracy ±0.1% of full scale		

(※1) : The flowrate (output signal and indication level) becomes zero at cutoff level lower. (Setting change by the customer is available.)

■ METER ERROR

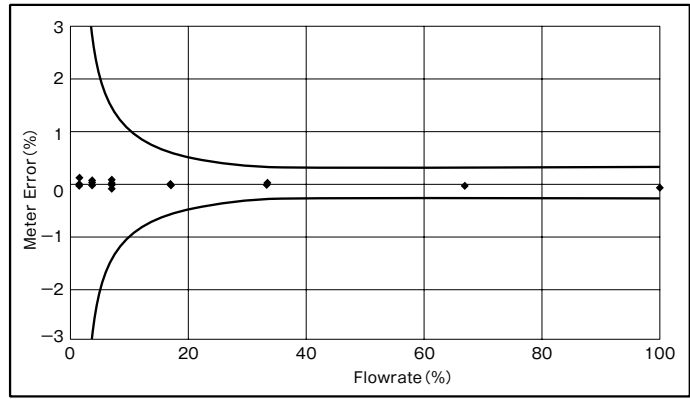

■ PRESSURE LOSSES

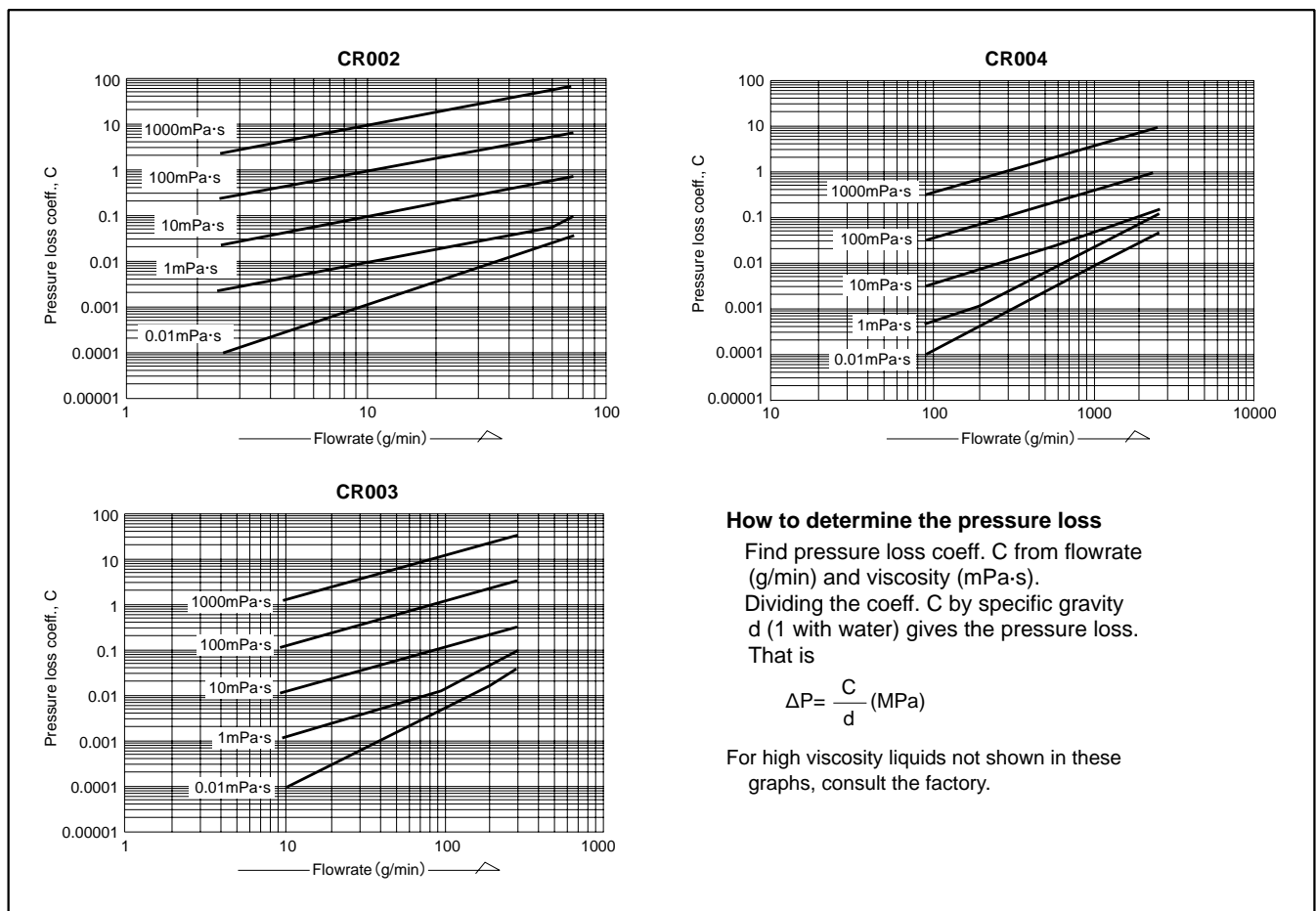

How to determine the pressure loss

Find pressure loss coeff. C from flowrate (g/min) and viscosity (mPa·s).  
Dividing the coeff. C by specific gravity d (1 with water) gives the pressure loss.  
That is

$$\Delta P = \frac{C}{d} \text{ (MPa)}$$

For high viscosity liquids not shown in these graphs, consult the factory.

■ PRODUCT CODE EXPLANATION

Item	Code No.												Description		
	①	②	③	④	⑤	⑥	-	⑦	⑧	-	⑨	⑩		⑪	⑫
Model	C	R													CoriMate
Nominal Size			0	0	2										0.7mm, Flow range (g/min) : 2.5 to 75 (Rc1/8)
			0	0	3										1.5mm, Flow range (g/min) : 10 to 300 (Rc1/8)
			0	0	4										3mm, Flow range (g/min) : 90 to 2700 (Rc1/8)
Structural category						D	-								CoriMate II
Material						S	S	-							SUS316L
Process connection										2					Screw connection
Connection rule											0				Always "0"
Pressure category												0			Always "0"
Transmitter construction														N	Non-explosionproof integral type transmitter

# OVAL Coriolis Flowmeters CoriMate II (Reference drawing)

OUTLINE DIMENSIONS [Unit in mm]

GS. No. GBN064E

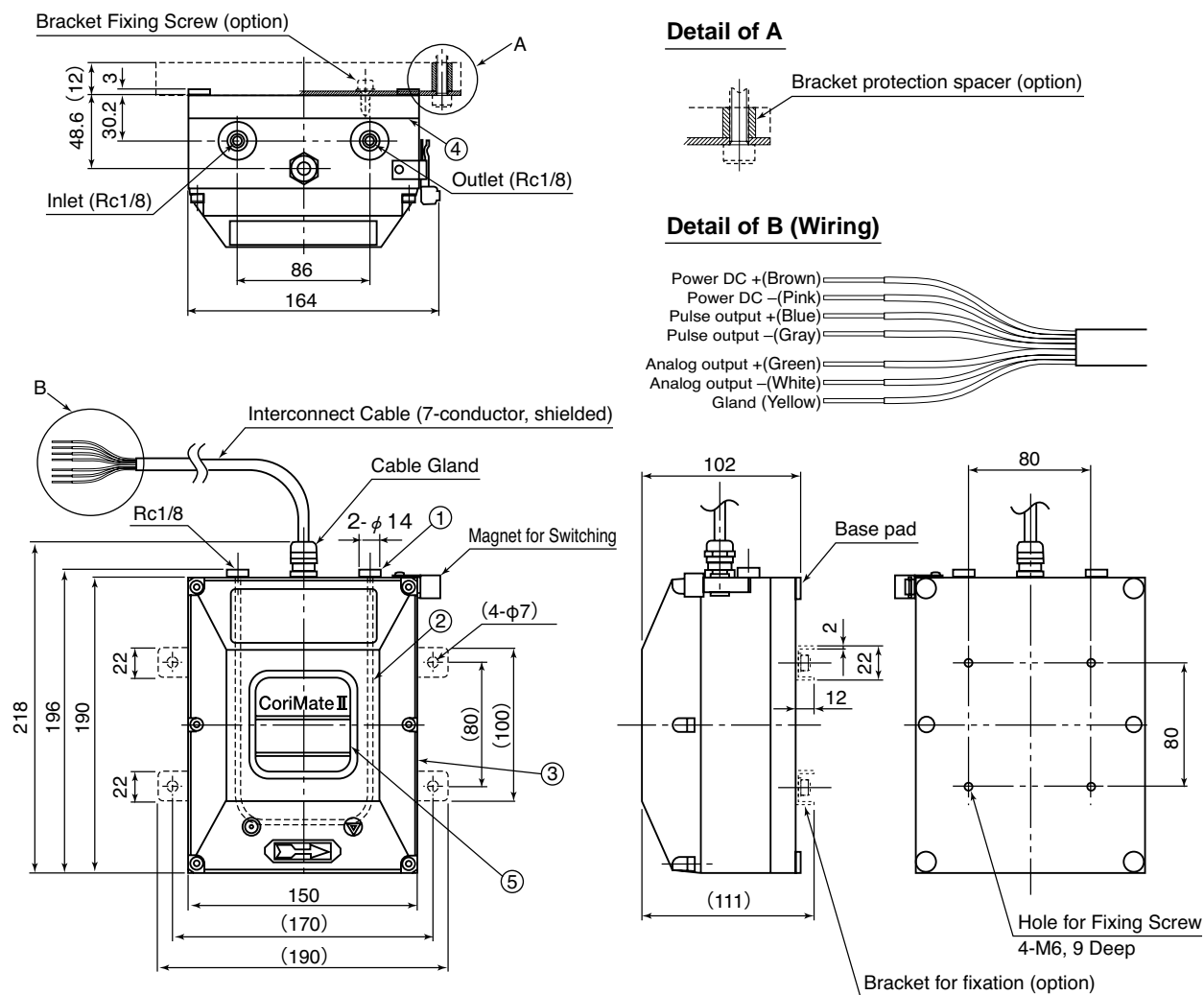

## ■ PRODUCT CODE EXPLANATION

C\FMD	Model	Nominal Size	Max. allowable pressure (MPa)	Weight Approx. (kg)
	CR002D-SS-200N	Rc1/8	2.00	6.0
	CR003D-SS-200N	Rc1/8	2.00	6.0
	CR004D-SS-200N	Rc1/8	2.00	6.0

No.	Name	Material	Quantity
①	Nozzle	SUS316L	2
②	Flowtube	SUS316L-TP	1
③	Housing and Cover	ADC12 equivalent	1
④	Base	SUS304	1
⑤	Display shielding	Polycarbonate	1

## ■ GENERAL SPECIFICATIONS

Item	Description
Acceptable fluid	Liquid (Density range : 0.3 to 2.0g/mL)
Liquid temperature	-10 to +60°C (Free of dew condensation)
Flow directions	Forward flow only
Power supply	20 to 30VDC
Power consumption	Max.10W
Cable	AWG24×7-conductor, 3m (finished OD : φ6.8mm)
Explosionproof configuration	Non-explosionproof
Dustproof, waterproof construction	IP66
Physical orientation	Horizontal (unnecessary to fix), Vertical (bracket for fixation is option)
Display	8 digits LCD, Backlit dot matrix
Variables displayed	Instant mass flow, mass flow total, temperature
Communication interface	Bell 202 (using the HART protocol)
Pulse output	Mass flow total open collector output (10V min. to 30V max. 50mADC)
	Flowrate span : 0.1 to 10000Hz selectable
Analog output	4 to 20mADC Max., load 600Ω, Instant mass flowrate
	Addition Damping : 0 to 200 sec (0 sec standard)

## ■ PLEASE SUPPLY THE FOLLOWING INFORMATION WHEN YOU INQUIRE

(Fill in the form below to the extent possible. Further details will be finalized in later consultation.)

•Fill in the blanks. Tick the boxes  that apply.

1. <b>Sensor unit</b>	CR <input type="checkbox"/> <input type="checkbox"/> <input type="checkbox"/> D-SS-200N
2. <b>Process fluid(*1)</b>	Name_____ SP. gr_____ Viscosity_____ Concentration_____%
3. <b>Flow range</b>	Max._____ Normal_____ Full scale_____ <input type="checkbox"/> g/min <input type="checkbox"/> Others_____
4. <b>Fluid temperature</b>	Max._____°C Normal_____°C Min._____°C
5. <b>Operating pressure</b>	Max._____MPa Normal_____MPa Min._____MPa
6. <b>Ambient temperature</b>	Max._____°C Normal_____°C

\*1 : Special fluids, such as of high viscosity or slurries, should be stated precisely and in detail.

The specification as of Sep., 2011 is stated in this GS Sheet. Specifications and design are subject to change without notice.



**Sales Representative:**  
**icenta CONTROLS Ltd**  
**North Station Yard, Warminster Road, Wilton, Salisbury, SP2 0AT**  
**Tel: +44 (0)1722 741890 Lo-Call: 0845 895 1020 Fax: +44 (0)1722 742031**  
**Email: sales@icenta.co.uk**  
**www.icenta.co.uk**

GS.No.GBN064E  
 初版 改訂 印刷

11.09		