



High Performance Inexpensive Vortex Flowmeter

DELTA FLOWPET
MODEL FLX

GENERAL SPECIFICATION
GS.No.GBD620E-4

■ **GENERAL**

DELTA FLOWPET combines OVAL's field-proven, stainless steel body industrial vortex flowmeter EX DELTA with a newly designed, small preamplifier featuring a flow switch. Besides fast delivery and competitively priced, it offers the best price/performance, rugged construction, and ease of operation.

■ **FEATURES**

1. Can monitor the total flow or instantaneous flowrate with an externally furnished selector magnet in the field.
2. A sturdy stainless steel body contains no moving parts to deteriorate from age and wear.
3. Inherently no limitation on physical orientation in meter installation.
4. Provides an output (total flow in pulse or instantaneous flowrate in analog form) for remote processing.



■ **GENERAL SPECIFICATIONS**

● **Meter Body**

Item	Description
Nominal Size	10, 15, 25, 40, 50, 80, 100mm
Process Connection	Wafer type
Flange Ratings	JIS 10, 16, 20, 30K ANSI/JPI 150, 300 (10mm in nominal size is not applicable.)
Standard Piping	Nominal thickness Sch. 40
Applicable Fluid	Liquid, gas, and steam (Steam is not acceptable for meters 10mm in nominal dia.)
Flow Range	See pages 2 and 3.
Operating Temp. Range	Standard models: -10 to +80°C, High temp. models: -10 to +200°C
Max. Operating Pressure	Depends on process connections. See table below. (Design pressure: 5.00MPa)
Accuracy	±1% of full scale or better (10mm in nominal size ±2% or better) (*: In analog output, ±0.5% of full scale is added.)
Material	Meter body, bluff body SCS14A (Nom. size 10mm, meter body: SS14A; Bluff body: SUS316) Sensor 10 to 25mm: SUS316, 40 to 100mm: XM19 (Super stainless steel) Adapter SCS13A
Physical Orientation	No limitation to cause loss of accuracy (Take into consideration ease of service, waterproof work at cable entry.)
Installation Location	Under the eaves (Avoid locations exposed to the sun.)

● **Converter**

Item	Description	
Model	PA55	
Mounting Design	Integrally mounted on the meter	
Display (digital LCD display)	1 Cumulative total flow (8-digit) 1, 2, 3, 4 are selectable with a selector magnet furnished external to the unit. 2 Instantaneous flowrate (hourly) 5-digit Shows the flow units (L, m ³ , g, kg, t, L (normal), m ³ (normal) and decimal point on the LCD. 3 Instantaneous flowrate (per-minute) 5-digit 4 Resettable total flow 7-digit (Display is rotatable through 360° for max. viewability.)	
Remote Output	Battery powered	None
	※ Externally powered	Analog output 4 to 20mA at 0 to FS (analog is adjustable with front-face switch.) Open collector output allowable current: 20mA Max. voltage applied: 30V
		Alarm output LED on top (red in color) indicates an alarmed status. (High and low alarm output status setpoints (ON/OFF select) are adjustable with a switch on top.) Pulse output Open collector output allowable current: 20mA Max. voltage applied: 30V Pulse width (Scaled pulse: 30ms; Unscaled pulse: 1ms)
Cable	5-conductor shielded cable (one meter long) ... furnished for externally powered model	
Transmission Length	Max.1km (conductor area 1.25mm ²)	
Power Supply	Battery powered	Lithium battery pack Good for 4 years (at room temperature) ... with low battery alarm
	Externally powered	12 to 45VDC
Installation location	① Free from rainwater and running water. ② Minimal temperature variation. ③ Not exposed to the direct rays of the sun.	
Construction	Non-explosionproof	
Material	Polycarbonate	
Backup	An EEPROM retains parameters and variables.	

※ : Analog output and open collector output cannot be used simultaneously.

● **Flange Ratings and Max. Operating Pressure (MPa)**

Flange Rating	JIS10K	JIS16K	JIS20K	JIS30K	ANSI/JPI 150	ANSI/JPI 300
Max. Pressure	1.18	1.96	2.45	4.51	1.21	3.20

OVAL Corporation

<http://www.oval.co.jp>

Head Office (Tokyo): Tel. 81-3-3360-5121. Fax. 81-3-3365-8605
Beijing Office: Tel. 86-10-5867-4711. Fax. 86-10-5867-4713
Overseas Branch Offices: Seoul, Singapore and Taipei

■ FLOW RANGES

● Liquid Service

Select the minimum flowrate from Table A (based on specific gravity) or Table B (based on viscosity), whichever is greater.

Table A (based on specific gravity) Unit: m³/h

Sp. gr. Size, mm	Min. Flowrate								Max. Rate
	0.5	0.6	0.7	0.8	0.9	1.0	1.1	1.2	
10	0.3	0.3	0.3	0.2	0.2	0.2	0.2	0.2	2.2
15	0.4	0.4	0.4	0.4	0.3	0.3	0.3	0.3	4.7
25	1.0	0.9	0.9	0.8	0.8	0.7	0.7	0.7	16
40	1.7	1.5	1.4	1.3	1.3	1.2	1.2	1.1	31
50	2.7	2.5	2.3	2.2	2.1	2.0	1.9	1.8	53
80	6.0	5.5	5.1	4.7	4.6	4.6	4.6	4.6	118
100	11	11	11	11	11	11	11	11	205

Table B (based on viscosity) Viscosity unit: mm²/s

K. viscosity Size, mm	Min. Flowrate (m ³ /h)									
	1	2	3	5	10	15	20	25	30	40
10		0.3	0.4	0.6	1.1					
15	0.4	1.2	1.8	2.9						
25				1.8	5.9					
40				2.8	6.5	14				
50				3.6	7.1	15	24			
80					11	16	26	38		
100					14	21	28	45	55	

Beyond the bounds of measurement

● In the shadowed area , determine using Table A (based on specific gravity).

● Gas Service

This table shows flow ranges in actual flowrate.

Size, mm	Density kg/m ³	Min. Flowrate (m ³ /h)										Max. Flowrate (m ³ /h)
		0.38	0.7	1.2	2.0	3.6	6	11	19	34	(60)	
10		4.5	3.3	2.6	2.2	1.8	1.5	1.3	1.1	0.9	0.7	8.5
15		9.4	6.9	5.4	4.6	3.8	3.2	2.6	2.2	1.8	1.5	18
25		23	17	13	12	10	8	7	6	5	4	60
40		39	29	23	19	16	13	11	9	8	6	119
50		63	46	37	31	26	22	18	15	12	10	199
80		140	101	80	67	56	47	38	32	26	22	741
100		240	174	140	115	95	80	66	55	45	37	1280

Kind of Gas	Density kg/Nm ³	Gas Pressure MPa (gauge) at 20°C										Gas Viscosity
		0.02	0.12	0.26	0.55	1.05	2	3.6	0.007(mPa·s)			
Argon	1.785	—	—	—	0.02	0.12	0.26	0.55	1.05	2	3.6	0.007(mPa·s)
Air	1.293	—	—	0	0.07	0.20	0.4	0.85	1.5	2.7	—	0.017
Oxygen	1.429	—	—	0	0.05	0.17	0.35	0.75	1.35	2.5	4.4	0.0192
Carbon dioxide	1.977	—	—	—	0.01	0.1	0.23	0.5	0.95	1.7	3.3	0.0138
Nitrogen	1.251	—	—	—	0.07	0.21	0.42	0.85	1.55	2.8	—	0.0166

○ How to Determine the Minimum Flowrate

Find a value nearest (lower value) to the applicable gas pressure in Table D, follow the same column upwards and find a value intersecting the desired nominal size in Table C for the minimum flowrate. If it is desired to determine the minimum flowrate more accurately, calculate as follows:

Example 1

Find the min. flowrate of a fluid: air, temperature: 20°C, pressure: 0.5MPa (gauge), and nom. size: 80mm.
 Solution: The min. flowrate at 0.4MPa and 0.85MPa of air with respect to nom. size 80mm in Table D are 47m³/h and 38m³/h, respectively, from corresponding Table C. The min. flowrate at 0.5MPa is thus determined by proportion as follows:

$$Q_{min} = 38 + \frac{0.85 - 0.5}{0.85 - 0.4} \times (47 - 38) \approx 45\text{m}^3/\text{h}$$

Or, it can be determined by calculating the actual density. Actual density ρ of air at 20°C and 0.5MPa is

$$\rho = 1.293 \times \frac{273.15}{273.15 + 20} \times \frac{0.1013 + 0.5}{0.1013} \approx 7.04\text{kg/m}^3$$

From Table C, the min. flowrate at a density of 6 and nom. size 80mm is 47m³/h; at a density of 11 is 38m³/h. The min. flowrate at a density of 7.04 can thus be found by proportion as follows:

$$Q_{min} = 38 + \frac{11 - 7.04}{11 - 6} \times (47 - 38) \approx 45\text{m}^3/\text{h}$$

Example 2

Find the min. flowrate and applicable nom. size of a fluid: carbon dioxide, temperature: 5 to 30°C, pressure 0.8 to 1.5MPa, max. flowrate: 1800m³/h (normal).

Solution: Firstly, find the actual max. flowrate and determine the nom. size. If there is some latitude in temperature and pressure, take the higher value for temperature and the lower value for pressure as the reference value in calculating the max. flowrate. The actual max. flowrate is thus calculated as follows:

$$Q_{max} = 800 \times \frac{273.15 + 30}{273.15} \times \frac{0.1013}{0.1013 + 0.8} \approx 99\text{m}^3/\text{h}$$

It follows that the nominal size is 40mm, and the min. flowrate is based on the lower value in temperature and the higher value in pressure.

From Tables C and D, the min. flowrate at 40mm size and 0.95MPa pressure is 9m³/h. At 1.7MPa pressure, it is 8m³/h. The actual min. flowrate is thus determined by proportion as

$$Q_{min} = 8 + \frac{1.7 - 1.5}{1.7 - 0.95} \times (9 - 8) \approx 8.3\text{m}^3/\text{h}$$

NOTE: If the calculation results in a figure with decimal places, ignore decimal places in the max. flowrate. In the min. flowrate, round off fractional results.

● Saturated Steam Service

Unit : kg/h

Pressure MPa (gauge)	Nominal size											
	15mm		25mm		40mm		50mm		80mm		100mm	
	Min.	Max.	Min.	Max.	Min.	Max.	Min.	Max.	Min.	Max.	Min.	Max.
0.049	5.4	15	14	51	22	102	36	172	79	641	135	1100
0.098	6.1	20	15	67	25	133	41	224	90	834	154	1440
0.196	8.0	29	20	98	33	194	54	325	118	1210	202	2090
0.294	9.5	38	24	128	40	254	64	425	141	1580	241	2730
0.392	11	47	27	158	45	313	74	524	162	1950	277	3370
0.490	13	56	30	187	51	371	83	621	181	2310	310	4000
0.588	14	65	33	216	56	429	91	718	199	2670	342	4620
0.686	15	73	36	245	61	487	99	815	217	3030	372	5240
0.785	16	82	39	275	65	545	107	912	234	3390	400	5860
0.883	17	91	42	303	70	602	114	1000	250	3750	428	6480
0.981	18	99	44	333	74	661	121	1100	265	4110	455	7100
1.08	19	108	47	362	78	718	128	1200	281	4470	481	7730
1.18	20	117	49	391	83	776	135	1290	295	4830	507	8350
1.27	21	125	52	417	86	827	141	1380	308	5150	529	8900
1.37	22	133	54	446	90	885	147	1480	323	5510	553	9520

■ CONVERTER - SCALED PULSE UNITS

The tables below show the scaled pulse units in volume flow.

To reduce into units other than volume flowrate in fixed conversion, such as normal flowrate, determine using tables A through D (pages 4 and 5).

Applicable Fluid	Nominal Size mm	Max. Flowrate m ³ /h (Unscaled pulse freq., Hz)	Nominal Meter Factor L/P (Nom. Unscaled pulse units)	Unscaled Pulse Output Freq. (Hz) Q: Volume flowrate m ³ /h	Scaled Pulse Units
					Standard (m ³ /P)
Liquids	10	2.2 (142.6)	0.004285	64.8 Q	0.01
	15	4.7 (97.83)	0.01335	20.8 Q	0.01
	25	16 (55.11)	0.08065	3.44 Q	0.01
	40	31 (189.0)	0.04556	6.10 Q	0.01
	50	53 (147.1)	0.1001	2.78 Q	0.1
	80	118 (98.49)	0.3328	0.835 Q	0.1
	100	205 (75.25)	0.7567	0.367 Q	0.1
Gases	10	8.5 (110.2)	0.02143	13.0 Q	0.01
	15	18 (74.93)	0.06673	4.16 Q	0.01
	25	60 (41.33)	0.4033	0.689 Q	0.1
	40	119 (145.1)	0.2278	1.22 Q	0.1
	50	199 (110.4)	0.5005	0.555 Q	0.1
	80	741 (123.7)	1.664	0.167 Q	1
	100	1280 (93.98)	3.784	0.0734 Q	1

■ SCALED PULSE UNITS FOR FIXED CONVERSION

When it is required that the volume flowrate (flowrate in terms of volume) be reduced to the equivalent flowrate under standard conditions (normal flowrate) or to the mass flowrate by multiplying a conversion factor in fixed conversion, the scaled pulse units are determined by the units selector tables shown below.

Case	Fluid	Fixed Conversion or Not	Table to Select
1	Gases	Conversion to normal conditions (normal flowrate)	A
2	Saturated steam	Conversion to mass flowrate	B
3	Gases	Conversion to mass flowrate	C
4	Liquids	Conversion to mass flowrate	D

● Case 1

"Conversion factor" is calculated by the following equation:

$$\text{Conversion factor} = \frac{273.15}{T+273.15} \times \frac{P+0.1013}{0.1013} \times \frac{Z_0}{Z}$$

(Except where significant influence is expected, it is assumed that $Z_n/Z = 1$.)

where T=Operating temp. (°C)

P=Operating pressure (MPa [gauge])

Z_n =Compressibility coefficient under standard conditions

Z=Compressibility coefficient under operating conditions

Table A

Nom. Size mm	Conversion Factor	Standard Scaled Pulse Units m ³ (normal)
10	0.50 to 4.66	0.01
	4.67 to 46.6	0.1
	46.7 to 60.0	1
15	0.50 to 1.49	0.01
	1.50 to 14.9	0.1
	15.0 to 60.0	1
25	0.50 to 2.47	0.1
	2.48 to 24.7	1
	24.8 to 60.0	10
40	0.50 to 4.38	0.1
	4.39 to 43.8	1
	43.9 to 60.0	10
50	0.50 to 1.99	0.1
	2.00 to 19.9	1
	20.0 to 60.0	10
80	0.50 to 1.99	0.1
	2.00 to 19.9	1
	20.0 to 60.0	10
100	0.50 to 2.64	1
	2.65 to 26.4	10
	26.5 to 60.0	100

● Case 2

Table B

Nom. Size mm	Saturated Steam Press. MPa	Standard Scaled Pulse Units kg
15	0.05 to 0.167	0.01
	0.168 to 1.46	0.1
25	0.05 to 0.355	0.1
	0.356 to 1.46	1
40	0.05 to 0.745	0.1
	0.746 to 1.46	1
50	0.05 to 0.265	0.1
	0.266 to 1.46	1
80	0.05 to 1.03	1
	1.04 to 1.46	10
100	0.05 to 0.392	1
	0.393 to 1.46	10

● Case 3

Table C

Nom. Size mm	Fluid Density in Service kg/m ³	Standard Scaled Pulse Units, kg
10	0.50 to 4.66	0.01
	4.67 to 46.6	0.1
	46.7 to 60.0	1
15	0.50 to 1.49	0.01
	1.50 to 14.9	0.1
	15.0 to 60.0	1
25	0.50 to 2.47	0.1
	2.48 to 24.7	1
	24.8 to 60.0	10
40	0.50 to 4.38	0.1
	4.39 to 43.8	1
	43.9 to 60.0	10
50	0.50 to 1.99	0.1
	2.00 to 19.9	1
	20.0 to 60.0	10
80	0.50 to 1.99	0.1
	2.00 to 19.9	1
	20.0 to 60.0	10
100	0.50 to 2.64	1
	2.65 to 26.4	10
	26.5 to 60.0	100

● Case 4

Table D

Nom. Size mm	Liquid Sp. Gr.	Standard Total Flow Units, kg
10	0.500 to 2.00	1
15	0.500 to 0.749	1
	0.750 to 2.00	10
25	0.500 to 1.23	10
	1.24 to 2.00	100
40	0.500 to 2.00	10
50	0.500 to 0.999	10
	1.00 to 2.00	100
80	0.500 to 2.00	100
100	0.500 to 1.32	100
	1.330 to 2.00	1000

■ PRESSURE LOSSES

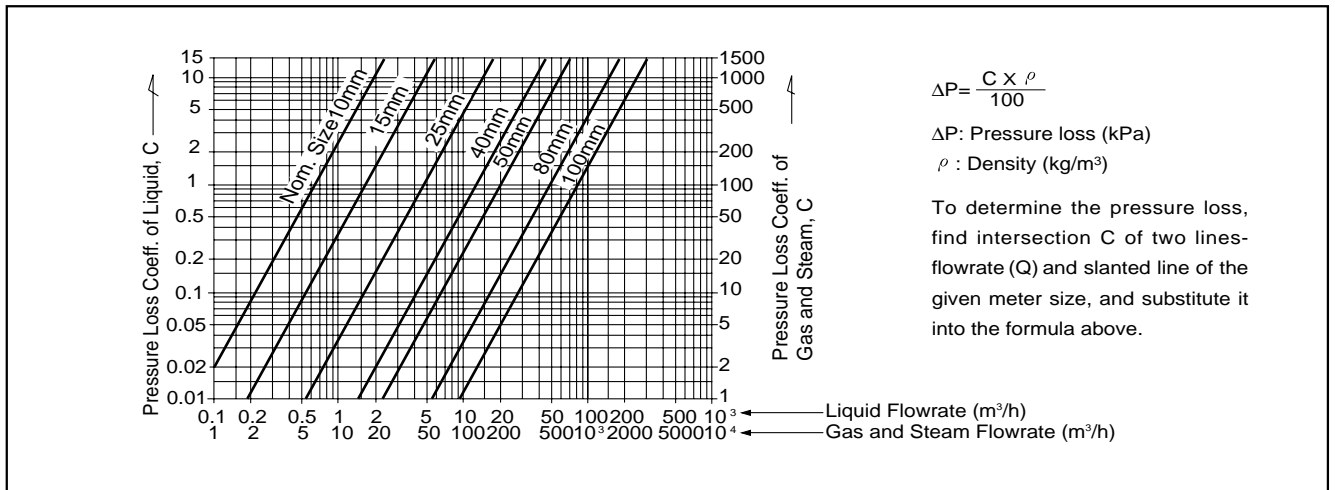

■ WIRING CONNECTIONS, EXTERNALLY POWERED TYPE

● **Analog Output (2-wire)**

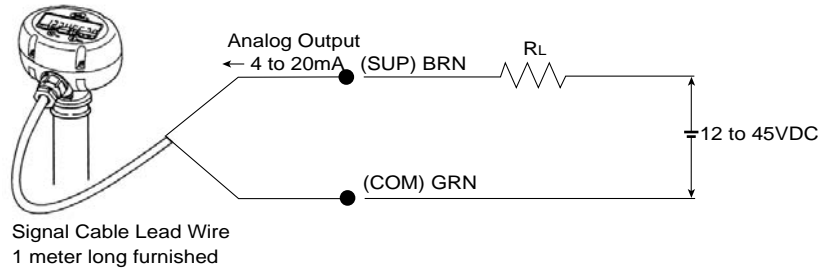

● **Scaled or Unscaled Pulse Output (3-wire)**

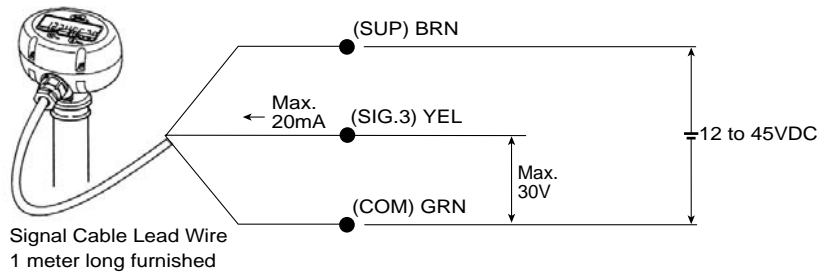

● **High/Low Alarm Output (2 outputs) (4-wire)**

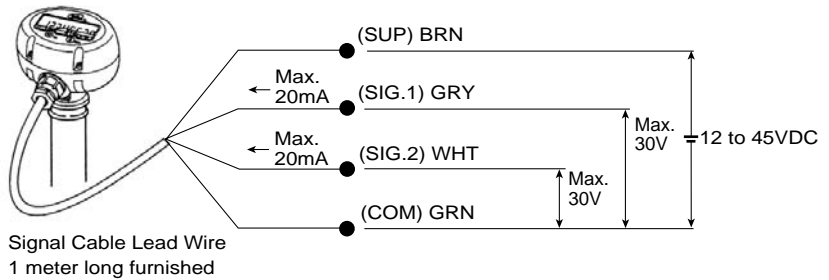

● **High/Low Alarm (2 output) + Scaled Pulse or Unscaled Pulse Output (5-wire)**

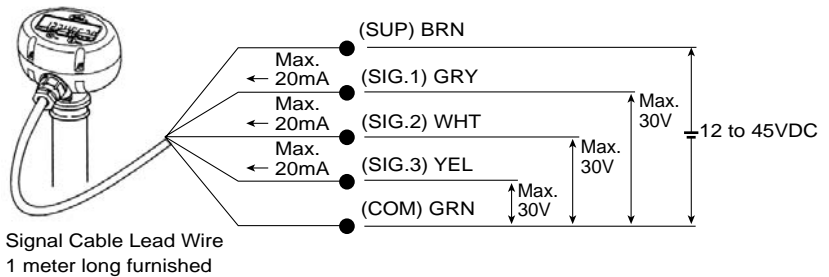

● **Polarities**

Lead Color	Description
BRN	SUP (and analog output)
GRY	SIG. 1 ... Alarm 1 output (high/low)
WHT	SIG. 2 ... Alarm 2 output (high/low)
YEL	SIG. 3 ... Factored/unfactored pulse output
GRN	COM

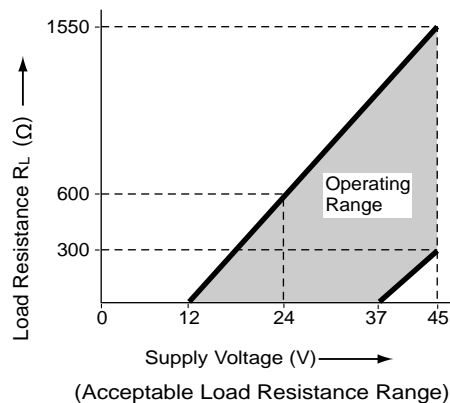

■ **OUTLINE DIMENSIONS (Unit: mm)**

● **Standard Type (Fluid temp.: -10 to +80°C)**

● **Nominal sizes: 10, 15mm**

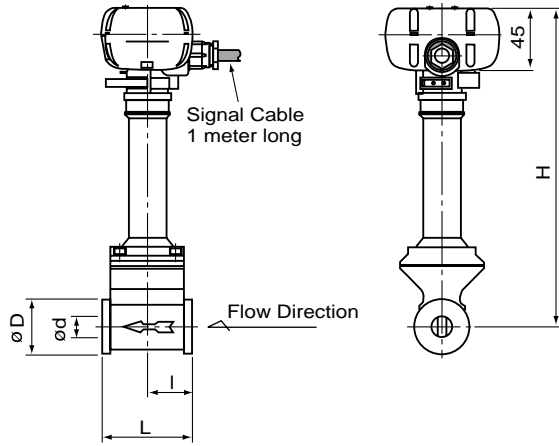

● **Nominal size: 25mm**

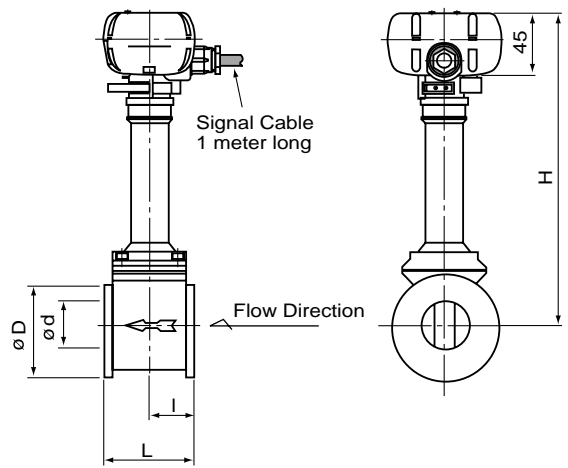

● **Nominal sizes: 40, 50mm**

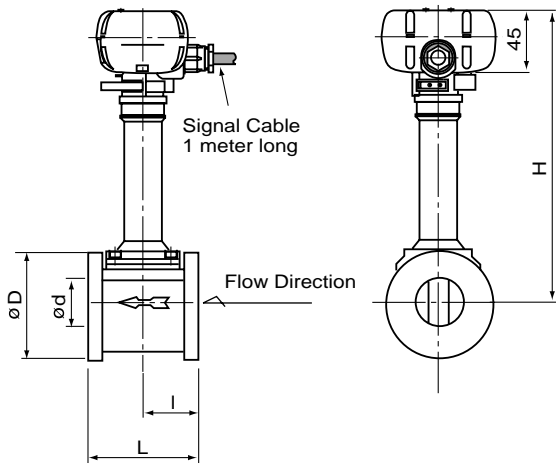

● **Nominal sizes: 80, 100mm**

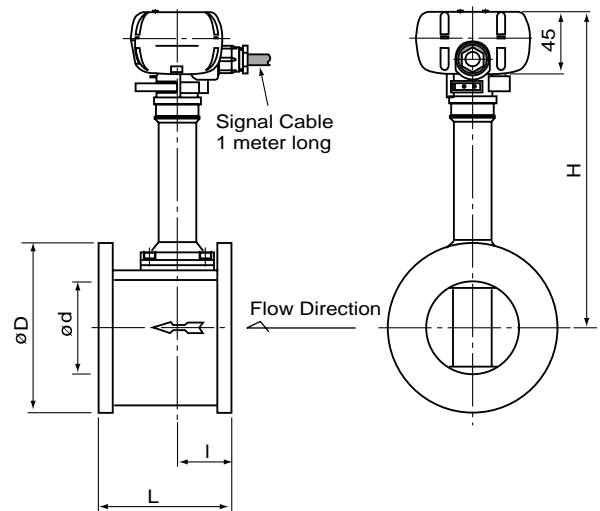

● **Display**

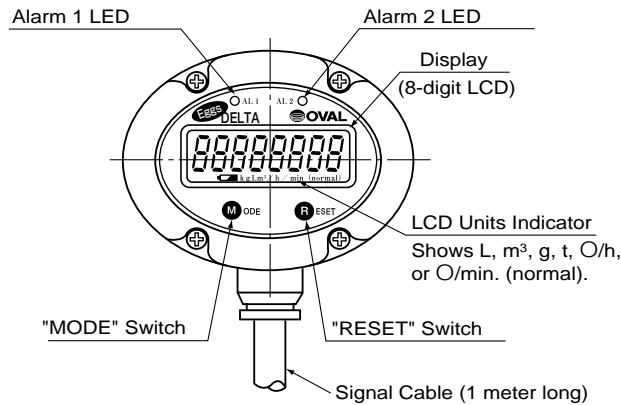

MODE/RESET is selectable with selector magnet furnished with the unit.

■ **OUTLINE DIMENSIONS (Unit: mm)**

● **High-temp. Type (Fluid temp.: -10 to +200°C)**

● **Nominal sizes: 10, 15mm**

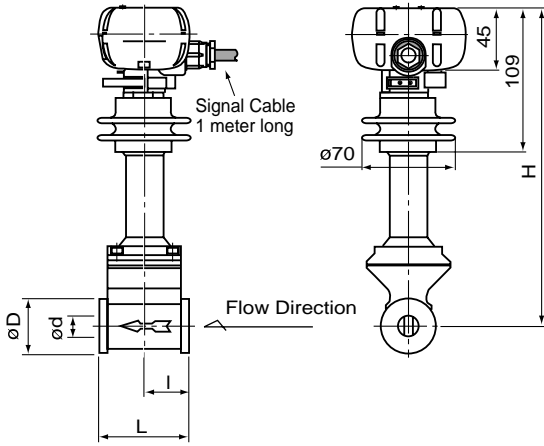

● **Nominal size: 25mm**

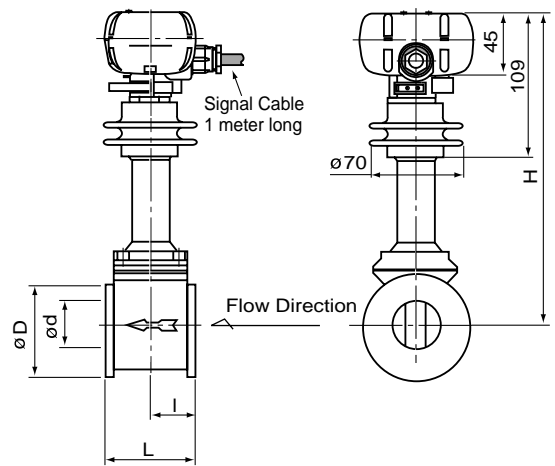

● **Nominal sizes: 40, 50mm**

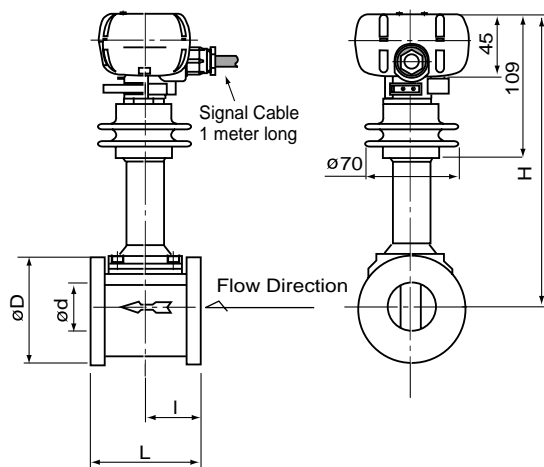

● **Nominal sizes: 80, 100mm**

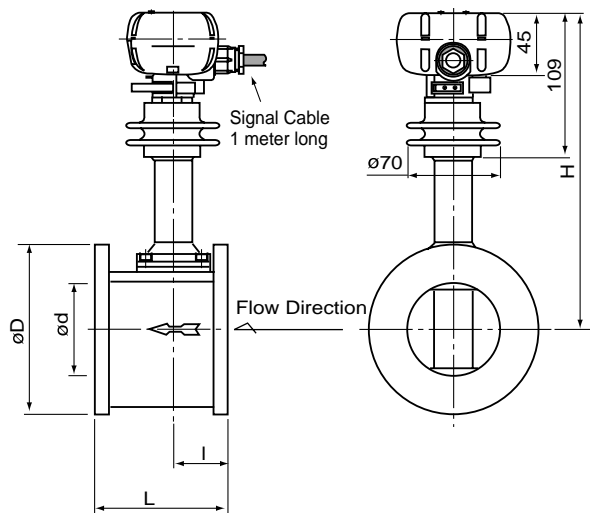

Nom. Size (mm)	L	I	ød	øD	H		Approx. Weight (kg)	
					-10 to +80°C service	-10 to +200°C service	-10 to +80°C service	-10 to +200°C service
10	65	32.5	10	40	232	264	1.4	1.6
15	65	32.5	14.5	40	232	264	1.4	1.6
25	65	32.5	26.6	67	232	264	2.0	2.2
40	80	40	37.6	81	217	249	2.7	2.9
50	80	40	48.5	91	221	253	2.8	3.0
80	100	40	72.4	126	237	269	5.6	5.8
100	125	48	95.2	156.2	257	289	9.3	9.5

■ INSTALLATION CONDITIONS

1. TYPICAL PIPING INSTRUCTIONS

It is generally required that the flow pattern of a fluid flowing in and out of an inferential type flow meter be as uniform as possible for accurate metering performance. All account of this, proper flow straightening measures

have to be applied for piping installation of EX DELTA. The standard piping instructions are shown in the following table.

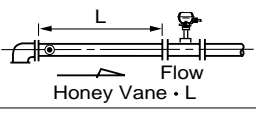
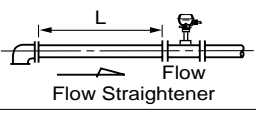
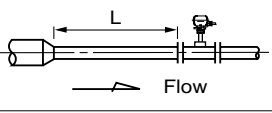
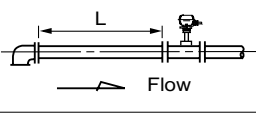
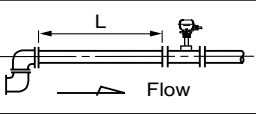
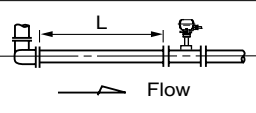
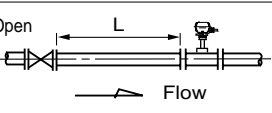
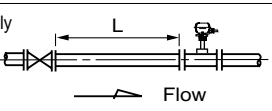
No.	Piping Arrangement	Straight Pipe Length(L)	Remarks	
1	OVAL's flow Straightener  Honey Vane • L Flow	8D	Refer to Paragraph 4 (page 10). Applicable to meter size>25mm.	
		 Flow Straightener Flow		12D
2	Reducer  Flow	15D Min.	A concentric reducer is upstream of the meter.	
3	Elbow  Flow	23D Min.	An elbow is upstream of the meter.	
		 Flow	25D Min.	Two elbows are upstream of the meter.
		 Flow	40D Min.	Two elbows are vertically upstream of the meter.
4	Fully open gate valve  Flow	15D Min.	A full-open gate valve is upstream of the meter.	
5	Partially open gate valve  Flow	50D Min.	A partially open gate valve, sharp orifice or something that markedly disturbs the flow pattern is upstream of the meter.	

Notes 1: Sch.40 pipe is used for the flow straightener.

2: A short pipe section, 5D or longer is provided downstream of the meter.

3: Taps for pressure gage and/or thermometer should be located downstream of the meter. (Fig. below).

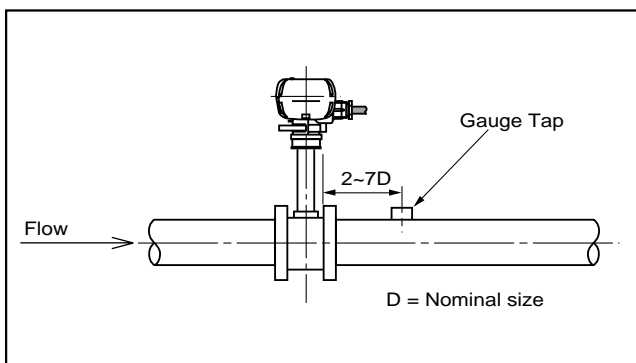

2. HEAT RETENTION WORK

If it is desired to thermally insulate the pipeline, simple lagging (without mortar finish) at the section where the meter is installed is suggested to facilitate servicing. This arrangement permits taking off flowmeter connecting bolts without breaking the lagging material.

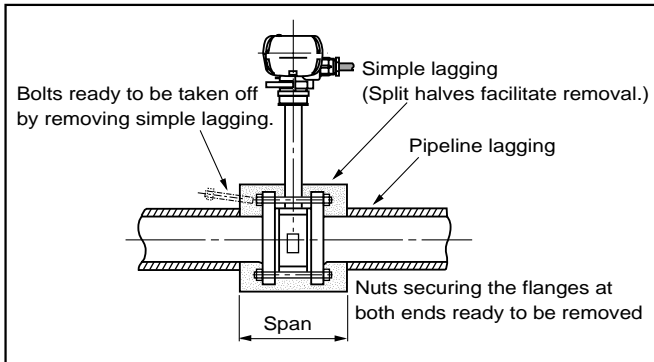

3. PRECAUTIONS TO BE TAKEN ON PROCESS CONDITIONS

(1) Preventing cavitation

In a liquid flow application, line pressure should be higher than the level calculated from the following equation to prevent cavitation:

$$P \geq 2.60\Delta P + 1.25P_o \text{ (MPa [abs])}$$

where ΔP : Pressure loss (MPa)

P_o : Vapor pressure of the liquid (MPa [abs])

(2) Pulsations

When the delta flowmeter is installed in a line where a pulsating pressure generating source, such as a Roots-blower and compressor, exists, care should be taken to the influences of ripples it may create. The allowable magnitude of pulsation pressure is given by the equation:

$$N < \frac{2.25 \rho V^2}{100} \text{ (kPa)}$$

where N: Pulsation pressure (kPa)

ρ : Density (kg/m³)

V: Min. flow velocity (m/s)

4. SPACE SAVING

If the required space for a straight pipe is not available upstream of the flowmeter due to installation space limitation, you can avoid the problem by installing a combination Honey Vane "S" and a short pipe.

● Honey Vanes

Outline Dimensions

Nominal size (mm)	ϕD ※ 1 (mm)	Honey Vane. S t (mm)	Honey Vane. L L (mm)
25	75	3.5	200
40	90	5.4	320
50	105	6.9	400
80	134	10.2	640
100	159	13.3	800

(※1) : Dimensions with JIS 10K.

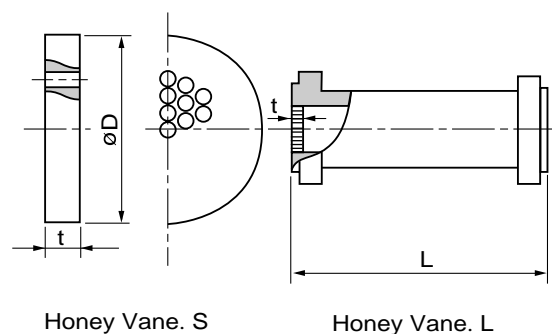

■ PRODUCT CODE EXPLANATION

Item	Code No.										Description		
	①	②	③	④	⑤	⑥	—	⑦	⑧	⑨		⑩	
Model	F	L	X									DELTA FLOWPET	
Nominal Size				0	1	0	—					10mm	
				0	1	5	—					15mm	
				0	2	5	—					25mm	
				0	4	0	—					40mm	
				0	5	0	—					50mm	
				0	8	0	—					80mm	
				1	0	0	—					100mm	
Flange Ratings								1				JIS 10K	
								2				JIS 16K	
								3				JIS 20K	
								4				JIS 30K	
								5				ANSI 150 (※1)	
								6				ANSI 300 (※1)	
								7				JPI 150 (※1)	
								8				JPI 300 (※1)	
								9				Other than above	
Applicable Fluid								G				Gas (−10 to +80°C)	Standard type
								L				Liquid (−10 to +80°C)	
								S				High-temp. gas (−10 to +200°C)	High-temp. type
								H				High-temp. liquid (−10 to +200°C)	
Output								0				None (battery powered)	
								1				Unscaled pulse	
								2				Scaled pulse output	
								3				Analog output	
								4				High/low alarm	
								5				Scaled pulse output + high/low alarm	
								6				Unscaled pulse output + high/low alarm	
Version												B	

(※1) : 10mm in nominal size is not applicable.

■ ORDERING INSTRUCTIONS

Please fill in the blanks or check the boxes below:

Item	Description
1. Fluid to the metered	
2. Flow range	Max. _____ Normal _____ Min. _____ <input type="checkbox"/> m ³ /h[normal] <input type="checkbox"/> m ³ /h[actual] <input type="checkbox"/> kg/h
3. Temperature range	Max. _____ Normal _____ Min. _____ °C
4. Pressure range	Max. _____ Normal _____ Min. _____ MPa [gauge]
5. Density or Sp. Gr.	Density _____ <input type="checkbox"/> kg/m ³ [normal], <input type="checkbox"/> kg/m ³ [actual] Sp. gr. _____
6. Viscosity	_____ <input type="checkbox"/> mPa·s, <input type="checkbox"/> mm ² /s at _____ °C
7. Process connection	Nominal size _____ <input type="checkbox"/> mm, <input type="checkbox"/> ", Flange rating <input type="checkbox"/> JIS _____ KRF <input type="checkbox"/> ANSI/JPI _____ RF
8. Flow straightener	<input type="checkbox"/> Req'd (Flow straightener and downstream pipe) <input type="checkbox"/> Not req'd (Prepare a straight pipe of specified length, I.D., Sch. No.)
9. Compensation	<input type="checkbox"/> Temp./press. comp. <input type="checkbox"/> Pressure comp. <input type="checkbox"/> Temp. comp.
10. Compensation range	Temp. _____ to _____ °C, Press. _____ to _____ MPa [gauge]
11. Compensation ref.	Ref. temp. _____ °C Press. ref. _____ MPa [gauge]
12. Compensation coeff. (gas measurement)	Z (service conditions) = _____ Zo (standard conditions) = _____
13. Accuracy test	<input type="checkbox"/> Req'd <input type="checkbox"/> Not Req'd
14. Converter	Type: <input type="checkbox"/> Integral construction <input type="checkbox"/> Separate construction Explosionproof construction: <input type="checkbox"/> Non-explosionproof <input type="checkbox"/> Flameproof
15. Output	<input type="checkbox"/> Unscaled pulse, <input type="checkbox"/> Scaled pulse, Pulse unit _____ / P <input type="checkbox"/> Analog output, Full scale _____ to _____ / h
16. Receiving instrument	<input type="checkbox"/> Separate-mount LCD counter <input type="checkbox"/> Remotely located receiver (Specify model and spec.)
17. Miscellaneous	

The specification as of July, 2008 is stated in this GS Sheet. Specifications and design are subject to change without notice.

Sales Representative:
icenta CONTROLS Ltd
 North Station Yard, Warminster Road, Wilton, Salisbury, SP2 0AT
 Tel: 0845 895 1020 Fax: 0845 895 1021
 Email: sales@icenta.co.uk
 www.icenta.co.uk



GS.No.GBD620E		
初版	改訂	印刷
01.9	08.7	