



Insertion type DELTA Flowmeter (for Exhaust Gas Measurement) MODEL VF

GENERAL SPECIFICATION
GS.No.GBD104E-3

■ GENERAL

Developed for large size pipelines, this instrument has a probe equivalent to a 2-inch (50A) delta meter to be inserted in the pipeline to determine the actual flow rate by measuring a representative flow velocity of the process fluid passing it. A thermistor sensor is used for Karman's vortex street detection.

■ FEATURES

1. A wide flow range at a high degree of accuracy.
2. Exceptionally small pressure loss to save energy.
3. A model with a gas-purge sensor allows high temperature gas measurement (up to 350°C).
4. The replaceable sensor assembly eliminates the need of interrupting the process flow while inspecting or replacing it.
5. Inherently insensitive to vibration in the surrounding environment.
6. There are no moving parts to wear out: long service life.

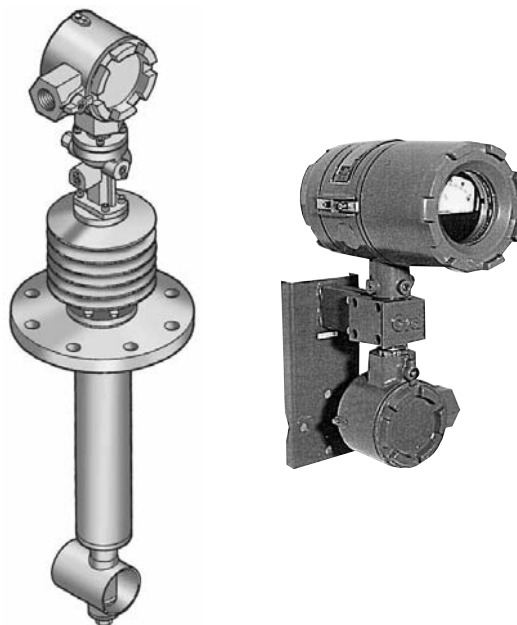

■ GENERAL SPECIFICATIONS

● Meter body

Item	Description
Installation	Inserted in the pipeline, fixed
Probe design	A thermistor sensor installed externally 1 Standard (clean gas service), 2 Gas-purge (dirty gas service), 3 Gas-purge type with radiator fins (dirty/high temp. gas service)
Applicable fluid	Gas
Nominal size to be applied	200 to 5000 mm
Nominal size of the probe	50mm
Materials	Measuring pipe: or SCS13A Bluff body: SUS304 or SCS13A Meter body: SUS304 or SCS13A
Max. operating pressure	0.971MPa
Operating temp. range	1 Standard: -40 to +130°C, 2 Gas-purge type: -40 to +130°C, 3 Gas-purge type with radiator fins: -40 to +350°C
Max. flow velocity	30m/s
Accuracy	±2% of full scale, or better
Physical orientation	No limit to affect meter accuracy. Typically horizontal. (Take into account ease of maintenance and waterproofing at cable entry.)
Mounting flange	100mm flange in nominal size. (RF standard) JIS 10, 20K, ANSI 150
Mounting nozzle length (Ln)	Ln=100mm (from pipe inner wall to mounting flange face)
Insertion depth (Y)	Y=0.5D when D<500 or Y=0.2D when D≥500 (where D: nominal pipe dia.)
Finish (terminal box)	Baked melamine. Color: Munsell 2.5G 8/2

● Converter

Item	Description	
Type	PA11, separately mounted type	
Operating temp. range	-10 to +60°C (when used in non-explosionproof rating: -20 to +60°C)	
Housing	Material	Watertight light alloy casing
	Finish	Munsell 7.5G/2.5, baked melamine
Field wiring	Probe-converter	3-conductor shielded cable 10 meters max. (intrinsically safe, explosionproof work)
	converter-receiver	3-conductor shielded cable 1 kilometer max. (flameproof work)
Output	Open collector output (capacitance : 27VDC, 20mA) Pulse width: 1ms	
Power	32VDC±2V	
Current drain	25mA max.	
Explosion-proof rating	Probe	Intrinsically safe explosionproof construction i3nG5
	Converter	Combined explosionproof construction id2G4
Mounting	Secured to a 2" pipe stanchion (mounting hardware and bolts furnished)	
Cable entry	G3/4 (internal thd.) Pressure-tight packing may be used (fittings optionally available)	
Flow indicator (option)	Scale	0 to 100% linear scale
	Full scale	100% at flowmeter's max. flow rate

OVAL Corporation

<http://www.oval.co.jp>

Head Office (Tokyo): Tel. 81-3-3360-5121. Fax. 81-3-3365-8605
Beijing Office: Tel. 86-10-5867-4711. Fax. 86-10-5867-4713
Overseas Branch Offices: Seoul, Singapore and Taipei

■ PURGING CONDITIONS (Gas-purge type)

1 Purging fluid: Clean, dry and noncorrosive gas (nitrogen gas, etc.)

2 Purging flow rate

Line pressure Pm	Pm ≤ 19.6kPa [gauge]	19.6 < Pm ≤ 294kPa [gauge]
Purging pressure	29.4kPa [gauge]	Pm + 49kPa [gauge]
Purging flow rate	* 0.5L/min (1L/min)	

* Purging rate 1L/min. is suggested in applications that come under the following conditions:

- Gases with large quantities of dust and mist
- Process fluid velocity is high (20 m/s or greater, for example).

■ PRESSURE LOSSES (*)

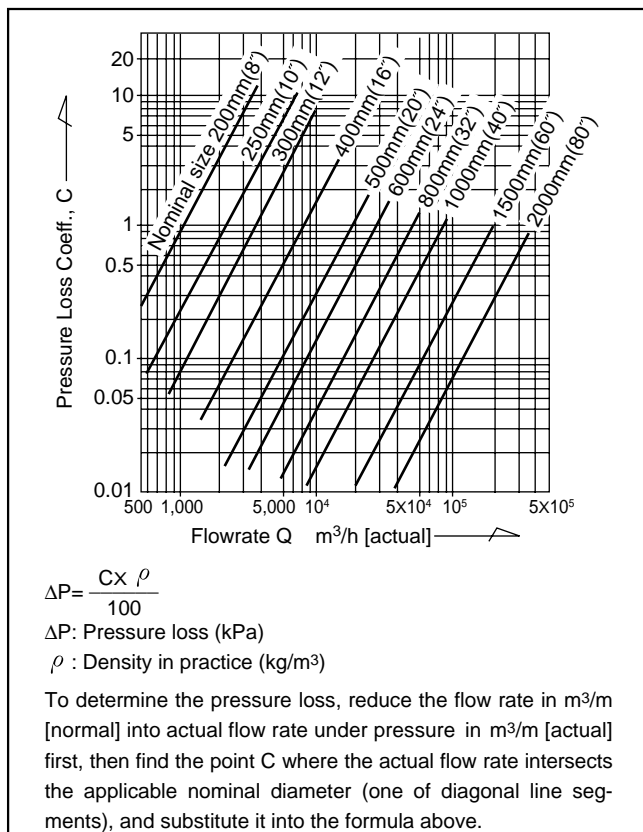

■ PURGE BOX OUTLINE DIMENSIONS (FB0₁)

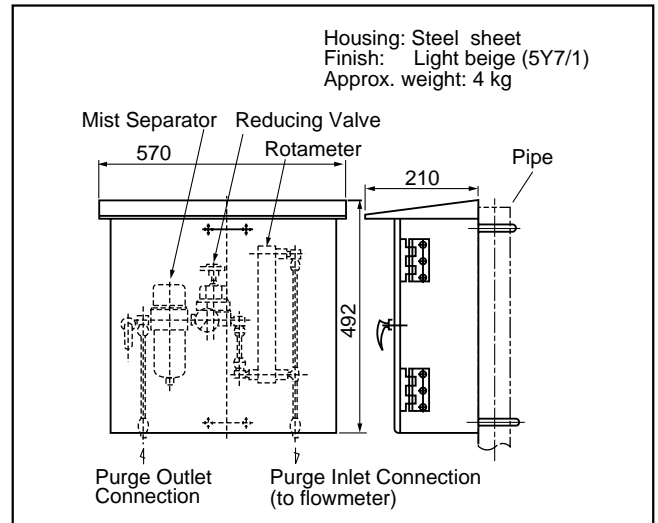

● Nominal meter factors (*)

Nominal pipe dia. mm	Nominal meter factor (L/P)	Pulse frequency at max. flow rate (Hz)	Max. flow rate (m³/h)
200 (8")	2.42	390	3,400
250 (10")	3.88	387	5,400
300 (12")	5.73	373	7,700
400 (16")	10.6	366	14,000
500 (20")	18.9	324	22,000
600 (24")	27.6	312	31,000
800 (32")	49.2	311	55,000
1000 (40")	76.8	307	85,000
1500 (60")	173	307	191,000
2000 (80")	308	306	339,000

* If nominal size exceeds 2000 mm, consult the factory.

■ PRODUCT CODE EXPLANATION

● Body

Item	Product Code															Description				
	①	②	③	④	⑤	⑥	⑦	⑧	-	⑨	⑩	⑪	-	⑫	⑬		⑭	⑮		
Model	V	F																Thermistor type delta flowmeter		
Nom. probe dia.	0	5	0															50mm		
Style				6														Sensor to be inserted externally		
Body material							D											SUS304 or equivalent		
Flange rating								1	-									JIS 10K		
								2	-									JIS 20K, ANSI 150		
Bluff body material										D								SUS304 or equivalent		
Probe construction											1							Standard		
											2							Gas-purge type (room temp. service)		
											3							Gas-purge type (high temp. service with heat radiator fins)		
Explosionproof specification												2	-					Explosionproof rating		
												6	-					Combined explosionproof		
Converter														1	1			Converter (PA11)		
Local indicator																0			Without local indicator	
																1			Local indicator provided	
Output signal																	0			Output not required
																	1			Unfactored pulse output

● Purge box

	Code	Description
Box for purging	FB01—	Pressure : 19.6kPa (gauge) or lower
	FB02—	Pressure : 19.6kPa (gauge) or higher (with flow controller)
Purge fluid	1	Non-flammable gases such as air or nitrogen
	2	Flammable gases

■ TYPICAL INSTALLATION

It is generally required that the flow pattern of a material moving into an inferential type meter be as uniform as possible for accurate metering. All account of this, proper flow straightening means must be taken when the application engineer considers installation of a delta flowmeter.

If you plan to cope with flow straightening problem with straight pipes alone, the length of straight pipes conforming to the ISO standard given in the table at right should be secured.

We also supply flow straighteners which are much shorter than straight pipes yet effective in this regard (up to 24" size). For complete details, see our technical data sheet, General Specification No. GCF001-E.

● Mounting nozzle

Flowmeter mounting nozzle dimensions are given below:

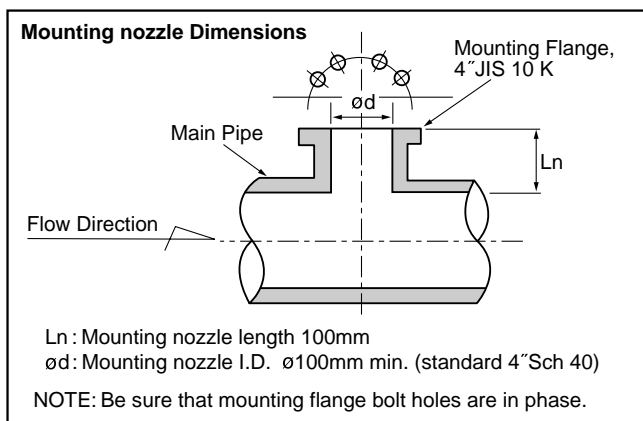

● Gage and/or thermometer location

Gage tap and/or thermometer tap, if required, should be located downstream of the meter as shown below:

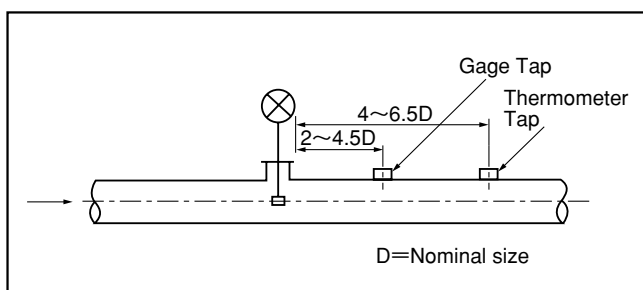

● When a flow straightener is connected
 Straight pipe lengths based on the ISO-5167 recommendations

Piping Arrangement	Straight Pipe Length, L	Description
Reducer	15D min.	A concentric reducer is upstream of meter.
Elbow	23D min.	An elbow is upstream of meter.
	25D min.	Two elbows are horizontally upstream of meter.
	40D min.	Two elbows are vertically upstream of meter.
Gate valve	15D min.	Full-open gate valve is upstream of meter.

On the downstream side:
 Provide a downstream pipe 5D long min.
 D is the nominal pipe diameter, not the nominal probe diameter.

● Pulsation

A precaution to remember: a Roots blower, compressor, or other pressure pulsation generating source present in a line where this delta flowmeter is installed may adversely affect meter performance.

Permissible pressure pulsation level is expressed in the following formula:

$$N < \frac{0.73 \rho V_2}{100}$$

where N: Pulsation pressure (kPa)

ρ : Density (kg/m³)

v: Minimum flow velocity (m/s)

● Lagging work

If heat retention of the pipeline is desired, we suggest a simple lagging (not mortar finished) over the area where the flowmeter is installed in order to facilitate meter inspection and disassembly. This arrangement will permit you to take off connecting bolts and service the flowmeter without ruining the cover of lagging material.

This General Specification is printed as of June, 2008 and all specifications are subject to change without notice for improvement.



Sales Representative:
icenta CONTROLS Ltd
 North Station Yard, Warminster Road, Wilton, Salisbury, SP2 0AT
 Tel: 0845 895 1020 Fax: 0845 895 1021
 Email: sales@icenta.co.uk
 www.icenta.co.uk

GS.No.GBD104E		
初版	改訂	印刷
00.5	08.6	