



# THERMISTOR TYPE DELTA FLOWMETER for St'd and Gas purge type MODEL VF SERIES

**GENERAL SPECIFICATION  
GS.No.GBD101E-16**

## ■ GENERAL

This flowmeter is a kind of vortex flowmeters, which makes use of the regular and periodic characteristics of Karman vortex street. A thermistor sensor picks up changes in flow velocity that come with vortex shedding in the manner - changes in thermistor temperature → changes in resistance value → a train of pulses proportional to the flow velocity. In the gas purge type, changes in fluid velocity that come with vortex shedding are replaced by changes in fluid velocity of a purge gas (clean gas) introduced from an external source.

Thanks to this arrangement, the thermistor sensor constantly remains in contact with clean, room temperature purge gas, permitting precise flow measurement of gases containing dust and mist, high or low temperature gases, or others previously thought difficult to be measured.

## ■ FEATURES

1. Gas purge type is primarily intended for metering gases containing dust and mist, or high or low temperature gases of broad flow ranges.
2. Total absence of mechanical moving parts and components subject to abrasion ensures long life and continuous operation with no loss of accuracy with time.
3. Provides a frequency output proportional to the flowrate to simplify counting pulses
4. Insensitive to changes in temperature, pressure and other physical properties.
5. Small pressure loss saves energy.

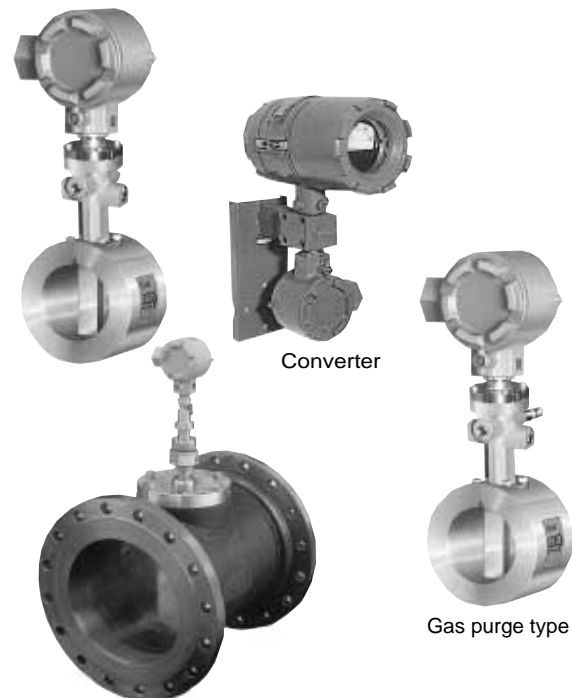

6. Replaceable sensor facilitates maintenance and servicing without the need of interrupting the gas flow.
  7. Pre-amplifier separated from the sensor body may be located anywhere for maximum ease of maintenance irrespective of piping conditions.
- We also supply indicator-equipped models for monitoring in the field.

## ■ GENERAL SPECIFICATIONS

### ● Standard Meter Body

Item	Description					
Body style	Flangeless			Flanged		
Nominal size (mm)	20, 25, 32, 50, 80, 100, 150		200, 250, 300		400, 500	
Material	Meter body	SUS304	STPG370	SUS304	STPY400	SUS304TP
	Flange	—	SFVC2A	SUSF304	SFVC2A	SUSF304
	Bluff body	SUS304	SCS13A(SUS304)			
Flange rating	(Piping Flange) JIS 10, 20, 30K ANSI 150, 300	JIS 10, 20, 30K ANSI 150, 300		JIS 10K ANSI 150		
Operating temp. range	-30 to +130°C	0 to+ 130°C	-30 to+ 130°C	0 to+ 130°C	-30 to+ 130°C	
Max. operating pressure	As per JIS and ANSI flange ratings					
Design pressure	5.00MPa	5.00MPa	5.00MPa	1.89MPa	1.89MPa	
Accuracy	±1% of RD or ±1% of FS					
Repeatability	±0.2% of better					
Installation	Horizontal or vertical					

# OVAL Corporation

<http://www.oval.co.jp>

Head Office (Tokyo): Phone. 81-3-3360-5121. Fax. 81-3-3365-8605  
Beijing Office: Phone. 86-10-5867-4711. Fax. 86-10-5867-4713  
Overseas Branch Offices: Seoul, Singapore and Taipei

## ■ GENERAL SPECIFICATIONS

### ● Gas-purge type meter body

Item		Description								
Applicable gas		Room temp. gas with dust and mist			High temp. gas service			Low temp. gas service		
Style		Flangeless	Flanged		Flanged			Flanged		
Nominal size (mm)		50	200	400	50	200	400	50	200	400
		80	250	500	80	250	500	80	250	500
		100	300		100	300		100	300	
		150			150			150		
Materials	body	SCS13A	STPG370	STPY400	STPG370	STPG370	STPY400	SUS304TP		
	Flanges	—	SFVC2A		SFVC2A			SUSF304		
Meter	Bluff body	SUS304	SCS13A (SUS304)		SCS13A (SUS304)			SUS304		
	Sensor housing	SCS13A								
Flange rating		—	JIS 10K							
Operating temp. range, °C		-30 to +130	0 to +130		+350 (Max. operating temp.)			-200 (Mni. operating temp.)		
Operating temp. span		50°C								
Max. operating pressure		0.971MPa								
Design pressure, MPa		5.00	5.00	1.89	5.00	5.00	1.89	5.00	5.00	1.89
Accuracy		Within ±1% of indicated reading, or within ±1% of full scale								
Repeatability		Within ±0.2%								
Installation		Horizontal or vertical								
Purge gas		Instrumentation air, nitrogen, or the same gas as the metered fluid								
Purge rate		0.5L/min to 1.0L/min at 19.6 to 29.4kPa								
Purge connection		Rc1/4 fitting provided								

### ● Converter

Item		Description
Model		PA11 separate-mount
Operating temperature range		-10 to +60°C (Non-explosionproof application, -20 to +60°C)
Housing	Material	Waterproof light metal alloy
	Finish	Munsell 2.5G 8/2
Field wiring	Sensor to transducer	3-conductor shielded cable, 10m max. (intrinsic safety explosionproof configuration)
	Transducer to receiver	3-conductor shielded cable, 1km max. (flameproof configuration)
Output signal		Transistor open collector output; Max. volts X current: 27V DC X 20mA; Pulse width: 1 ms.
Power supply		32VDC±2V
Current drain		25mA max.
Type of explosion protection	Sensor	Intrinsic safety i3nG5
	Converter	Flameproof id2G4
Installation		Mounting on 2" pipe stand (clamp and bolts furnished)
Conduit connection		G 3/4 (internal thread), Flameproof packing type leading method possible (cable attachment available as an option).
Flow indicator *	Scale	0 to 100% graduations (linear scale)
	Full scale	Flowmeter's max. flowrate to be 100%

\* Option

### ● Meter Factors

Nominal Size mm (inch)	Nominal Meter Factor L/P	Pulse Freq. at Max. Flowrate Hz	Max. Flowrate m <sup>3</sup> /h
20(3/4)	0.008438	411.5	12.5
25(1)	0.01733	408.7	25.5
32(1 1/4)	0.03852	407.4	56.5
50(2)	0.1260	407.8	185
80(3)	0.4197	350.8	530
100(4)	0.9432	265.1	900
150(6)	3.033	192.3	2100
200(8)	7.032	134.3	3400
250(10)	13.57	106.4	5200
300(12)	23.26	89.6	7500
400(16)	52.38	63.6	12000
500(20)	102.8	51.3	19000

**FLOW RANGES**

The Delta Flowmeter for gas service measures actual flow rate (m<sup>3</sup>/h[actual]) of gas under pressure. If a flowrate information is given under the standard conditions (0°C, 1 atmospheric pressure) (m<sup>3</sup>/h[normal]), it must be converted into an actual flowrate before you refer to the flowrange table, frequency characteristics and pressure loss graphs below.

Nom. size mm	Sp. weight kg/m <sup>3</sup>	Accuracy	Minimum flowrate m <sup>3</sup> /h [actual]													Max. Flowrate m <sup>3</sup> /h	
			0.08	0.12	0.22	0.38	0.7	1.2	2.0	3.6	6	11	19	34	60		
Table A	20 (3/4")	±1% of reading	—	—	—	—	—	9	5	3	2	1	0.7	0.5	0.4	12.5	
		±1% of full scale	—	—	—	○ 9	○ 6	○ 5.5	○ 3.1	1.8	1.1	0.8	0.7	0.5	0.4		
	25 (1")	±1% of reading	—	—	—	—	18	12	7	4	2.5	1.5	1	0.8	0.6	25.5	
		±1% of full scale	—	—	○ 19	○ 11	○ 7.5	○ 6.5	4	2.3	1.8	1.3	1	0.8	0.6		
	32 (1-3/4")	±1% of reading	—	—	—	23	20	15	9	6	4	2.2	1.7	1.3	1.0	56.5	
		±1% of full scale	—	—	○ 24	○ 14	○ 9.5	○ 8.5	5	4	3.0	2.2	1.7	1.3	1.0		
	50 (2")	±1% of reading	—	—	115	68	46	42	25	21	18	14	12	10	8	185	
		±1% of full scale	90	65	35	26	20	15	11	8.5	6.5	5	3.7	2.8	2.1		
	80 (3")	±1% of reading	440	320	170	100	69	63	48	40	33	27	23	19	16	530	
		±1% of full scale	130	100	75	58	43	32	25	19	15	11	8	6	5		
	100 (4")	±1% of reading	600	420	230	135	90	75	64	52	44	36	30	25	21	900	
		±1% of full scale	175	125	81	62	45	35	27	20	16	12	9	8	8		
	150 (6")	±1% of reading	880	620	340	200	155	130	110	90	76	62	52	43	36	2,100	
		±1% of full scale	290	240	180	135	100	75	60	44	34	26	26	26	26		
	200 (8")	±1% of reading	1150	800	430	280	230	190	160	130	110	90	75	60	50	3,400	
		±1% of full scale	510	420	310	240	170	140	100	80	60	50	50	50	50		
	250 (10")	±1% of reading	1400	1000	540	380	300	250	215	175	150	130	100	100	100	5,200	
		±1% of full scale	800	650	480	370	270	210	160	120	100	100	100	100	100		
	300 (12")	±1% of reading	1700	1200	680	520	400	330	270	225	190	170	170	170	170	7,500	
		±1% of full scale	1200	930	680	520	380	300	230	170	170	170	170	170	170		
400 (16")	±1% of reading	2200	1600	1200	890	700	500	410	380	380	380	380	380	380	12,000		
	±1% of full scale	2000	1600	1200	890	650	500	390	380	380	380	380	380	380			
500 (20")	±1% of reading	3100	2500	1900	1400	1050	800	750	750	750	750	750	750	750	19,000		
	±1% of full scale	3100	2500	1900	1400	1050	800	750	750	750	750	750	750	750			
Table B	Type of Gas	Sp. weight kg/Nm <sup>3</sup>	Pressure of Gas MPa (gauge)										Temperature 20°C				Find the value closest to the pressure of gas to be used (lower value) in Table B and determine the minimum flow rate in Table A.
	Acetylene	1.175	—	—	—	—	—	—	0	0.0785	0.226	0.539	0.883	1.62	2.94	(5.30over)	
	Argon	1.785	—	—	—	—	—	—	—	0.0196	0.118	0.255	0.539	1.03	1.96	3.43"	
	Carbon Monoxide	1.250	—	—	—	—	—	—	0	0.0686	0.206	0.412	0.834	1.52	2.75	5.00"	
	Ethane	1.357	—	—	—	—	—	—	0	0.0588	0.177	0.363	0.785	1.37	2.55	4.61"	
	Ethylene	1.264	—	—	—	—	—	—	0	0.0686	0.206	0.412	0.834	1.52	2.75	5.00"	
	Air	1.293	—	—	—	—	—	—	0	0.0686	0.196	0.392	0.834	1.47	2.65	4.90"	
	Oxygen	1.429	—	—	—	—	—	—	0	0.0490	0.167	0.343	0.735	1.32	2.45	4.31"	
	Hydrogen	0.0899	0	0.0392	0.157	0.343	0.716	1.30	2.26	4.12	(6.96)	(12.7)	(22.1)	(39.6)	(69.6)"		
	Carbon Dioxide	1.977	—	—	—	—	—	—	—	0.00981	0.0981	0.226	0.490	0.932	1.67	3.14"	
	Nitrogen	1.251	—	—	—	—	—	—	0	0.0686	0.206	0.412	0.834	1.52	2.75	5.00"	
	City Gas	0.802	—	—	—	—	0	0.0588	0.167	0.373	0.686	1.37	2.40	4.41	(7.85)"		
	Natural Gas	0.828	—	—	—	—	0	0.0588	0.157	0.363	0.667	1.32	2.35	4.22	(7.55)"		
	Freon—12	5.533	—	—	—	—	—	—	—	0	0.0196	0.118	0.265	0.549	1.08"		
	Propane	2.020	—	—	—	—	—	—	0.00981	0.0883	0.216	0.481	0.883	1.67	3.04"		
Butane	2.703	—	—	—	—	—	—	0	0.0392	0.137	0.333	0.637	1.18	2.26"			
Methane	0.717	—	—	—	—	0	0.0785	0.196	0.431	0.785	1.52	2.75	4.90	(8.73)"			

- NOTES: 1. Figures in brackets ( ) are for reference purpose only and not commercially available.  
 2. Mark ○ : Accuracy ±3% of full scale, Mark ◎ : Accuracy ±2% of full scale.  
 3. If it is desired to determine the minimum flow rate precisely, refer to "How to Determine Minimum Flow rate" below.  
 4. In case of full scale accuracy, the full scale value should be greater than 50% of the maximum flow rate above.

**How to Determine Minimum Flowrate**

**Example 1** A 200mm (8") size meter is to be used for air having a pressure of 0.834MPa [gauge] at room temperature. Find the minimum flowrate.

[Solution] Finding the minimum flowrate for nominal size 200mm (8") in Table A corresponding to 0.834MPa [gauge] air in Table B, we obtain:

where accuracy is ±1% of reading 90m<sup>3</sup>/h, where accuracy is ±1% of full scale 50m<sup>3</sup>/h

**Example 2** A 250mm (10") size meter is to be used for city gas having a pressure of 0.245MPa [gauge] at room temperature with an accuracy of ±1% of reading. Find the minimum flowrate.

[Solution] Finding the minimum flowrate for nominal size 250mm (10") in Table A corresponding to 0.373MPa [gauge] and 0.167MPa [gauge] of city gas in Table B are 175m<sup>3</sup>/h and 215m<sup>3</sup>/h, respectively. Hence, at 0.245MPa [gauge] we obtain from the rule of proportion:

$$Q_{min} = 175 + \frac{0.373 - 0.245}{0.373 - 0.167} \times (215 - 175) \approx 200m^3/h$$

**Example 3** A 200mm (8") size meter is to be used for butane gas having a pressure of 0.637MPa [gauge] at 80°C with an accuracy of 1% of reading. Find the minimum flowrate.

[Solution] Although the minimum flowrate in Table A corresponding to 0.637MPa [gauge] is 75m<sup>3</sup>/h, it has a higher minimum flow rate by the amount of decrease in specific weight as a result of elevated temperature as follows:

$$\text{Butane Sp. weight } \gamma = 2.703 \times \frac{0.10332 + 0.637}{0.10332} \times \frac{273.2}{273.2 + 80} = 15.1kg/m^3$$

$$\text{Hence } Q_{min} = 75 + \frac{19 - 15.1}{19 - 11} \times (90 - 75) \approx 82m^3/h$$

**PERFORMANCE CHARACTERISTICS**

**Output Frequency Characteristics by Size**

There is a perfect linear relationship between flowrate and output frequency. "Flowrate vs. output frequency characteristics" by nominal size are shown in the figure below.

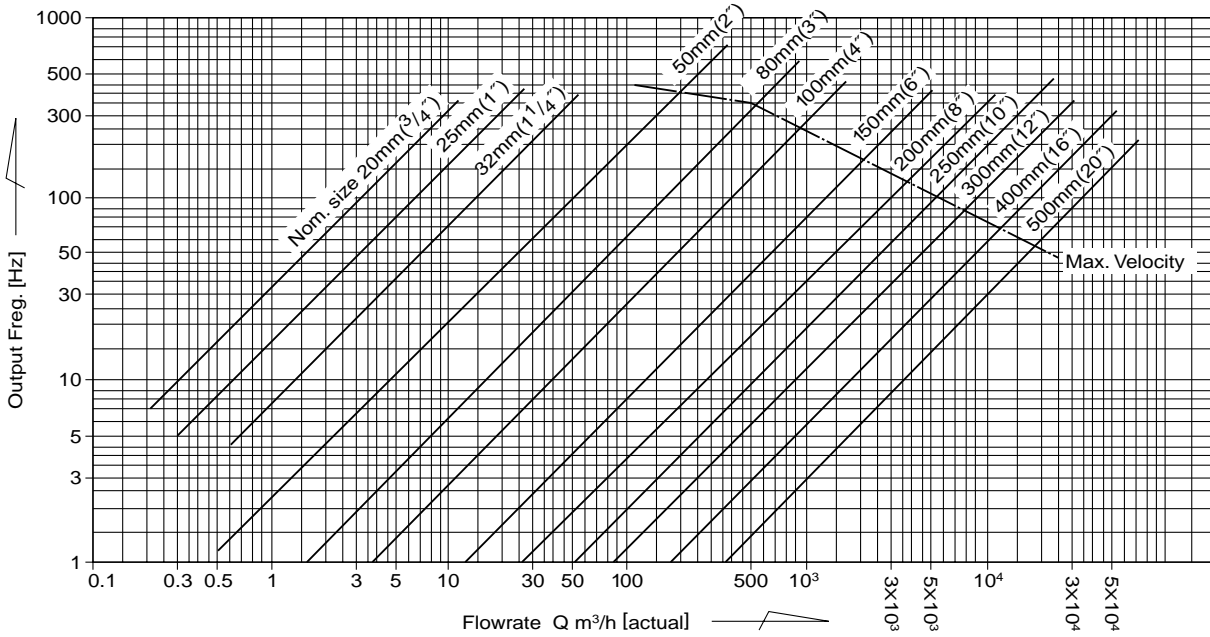

**Pressure Loss**

One obvious advantage of DELTA meters is their exceptionally small pressure loss. Shown in the figure below is the pressure losses by nominal size.

**Nominal sizes 20 to 32mm**

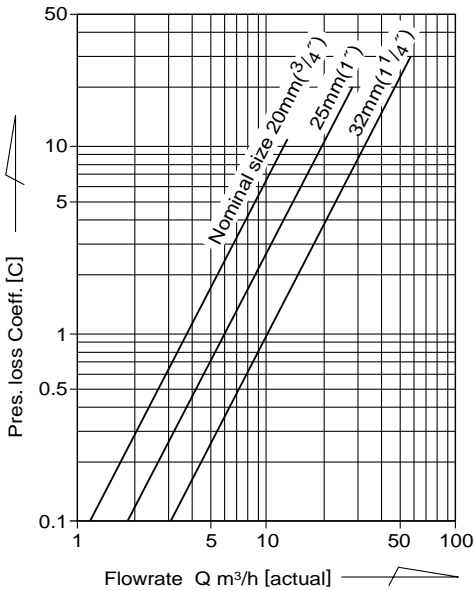

**Nominal sizes 50 to 500mm**

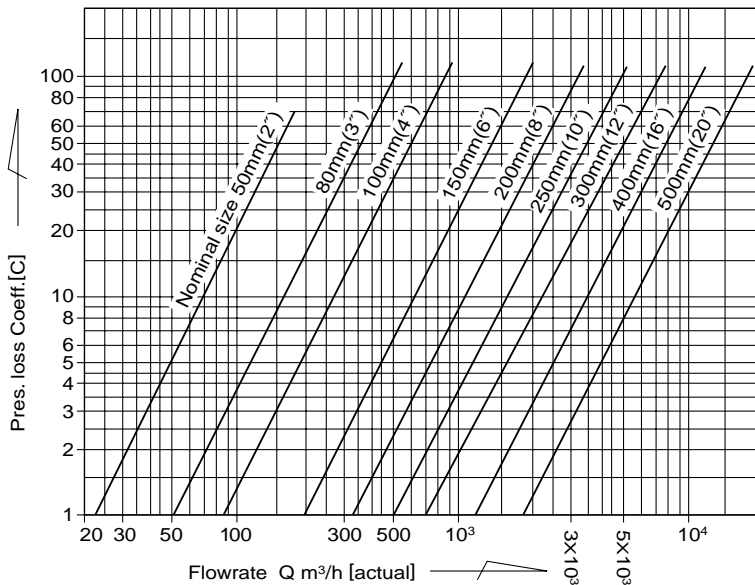

$$\Delta P = \frac{C \times \gamma}{100}$$

$\Delta P$  : Pressure loss (kPa)  
 $\gamma$  : Sp. weight (kg/m<sup>3</sup>)

To find the pressure lose, read the coefficient C at the intersection of the flowrate Q and the solid line of the particular size and determine  $\Delta P$  by the equation above.

■ OUTLINE DIMENSIONS (Unit in mm)

● Flangless 20mm (3/4")

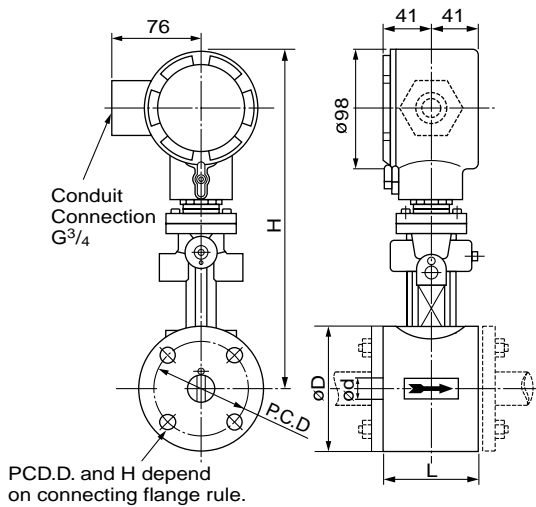

● Flangless 25mm (1") to 150mm (6")

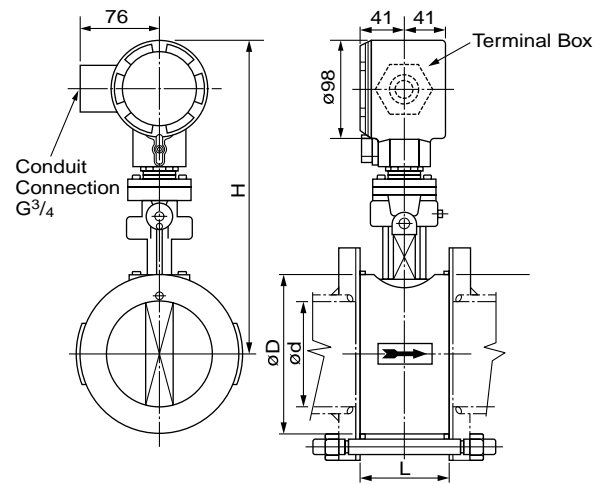

● Flanged 200mm (8") to 500mm (20")

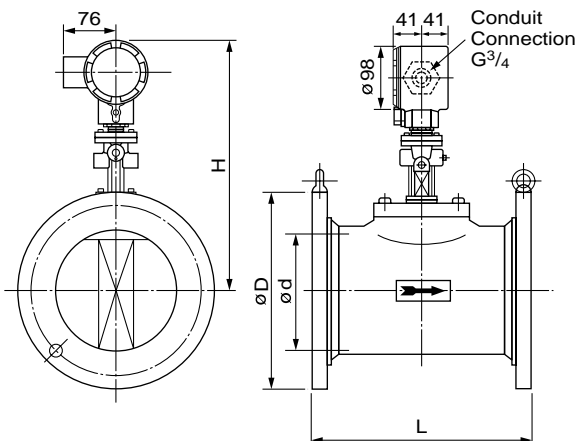

Style	Nom. size mm(inch)	Flange rating	L	H	d	D	Approx. Weight (kg)
Flange less	20 (3/4)	Companion Flange	80	285	21.4	100	7
	25 (1)	JIS 10 K FF	80	273	27.2	70	4.5
	32 (1 1/4)	JIS 20 K RF	80	277	35.5	80	5.0
	50 (2)	JIS 30 K RF	80	280	52.7	92	5.9
	80 (3)	ANSI 150 RF	80	299	78.1	127	9.1
	100 (4)	ANSI 300 RF	86	314	102.3	157.2	11
	150 (6)		108	349	151	216	20.4
Flanged	200 (8)	JIS 10 K FF	350	396	200	330	60
		JIS 20 K RF				350	74
		JIS 30 K RF				370	89
		ANSI 150 RF				343	70
		ANSI 300 RF				381	94
	250 (10)	JIS 10 K FF	450	428	249	400	100
		JIS 20 K RF				430	125
		JIS 30 K RF				450	151
		ANSI 150 RF				406	110
		ANSI 300 RF				445	146
	300 (12)	JIS 10 K FF	500	469	298	445	140
		JIS 20 K RF				480	168
		JIS 30 K RF				515	213
		ANSI 150 RF				483	165
		ANSI 300 RF				520	216
	400 (16)	JIS 10 K FF	600	519	390.6	560	240
		ANSI 150 RF				595	365
	500 (20)	JIS 10 K FF	650	579	489	675	430
ANSI 150 RF		700				590	

● In case the meter is used for metering gases of the following specifications, the pressuretight seal (P.T.S) type applies and the dimension H<sub>1</sub> increases by 91mm.

(1) Fluid name : H<sub>2</sub>, LPG (C<sub>2</sub> to C<sub>4</sub>), LNG, City gas, and

(2) Pressure : 1.47 to 5.00MPa, and

(3) Temperature : -20 to +100°C

(If the temperature exceeds 100°C, consult factory.)

● For insertion type of outline dimensions, refer to general specification sheets.



● Purge Box (FB0<sub>2</sub>)

(Unit in mm)

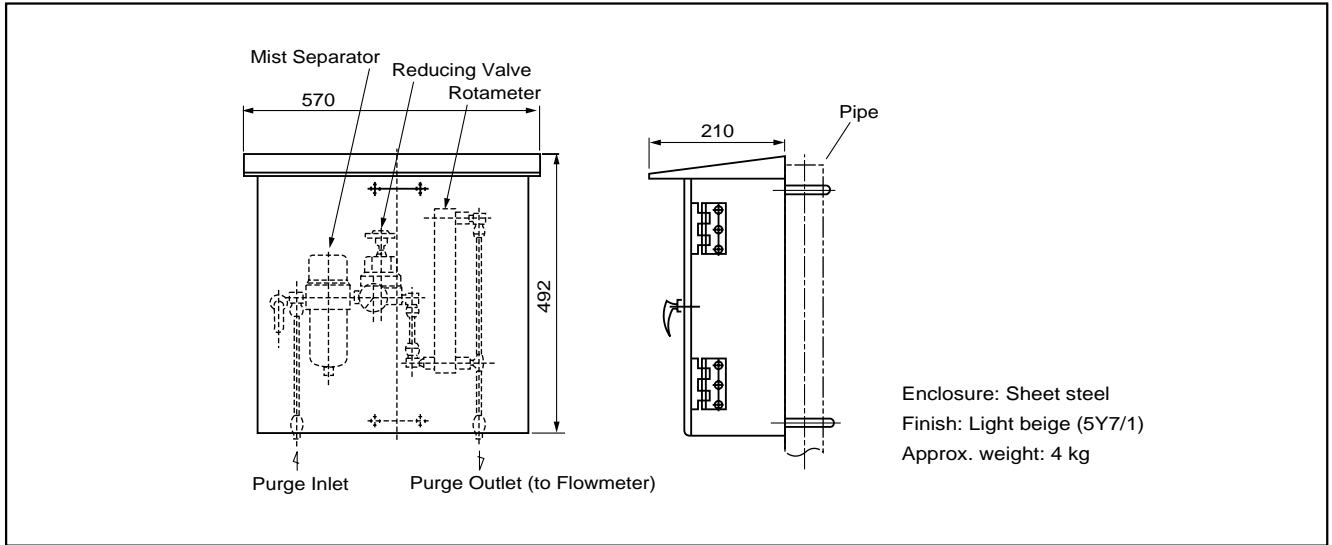

● Converter

(Unit in mm)

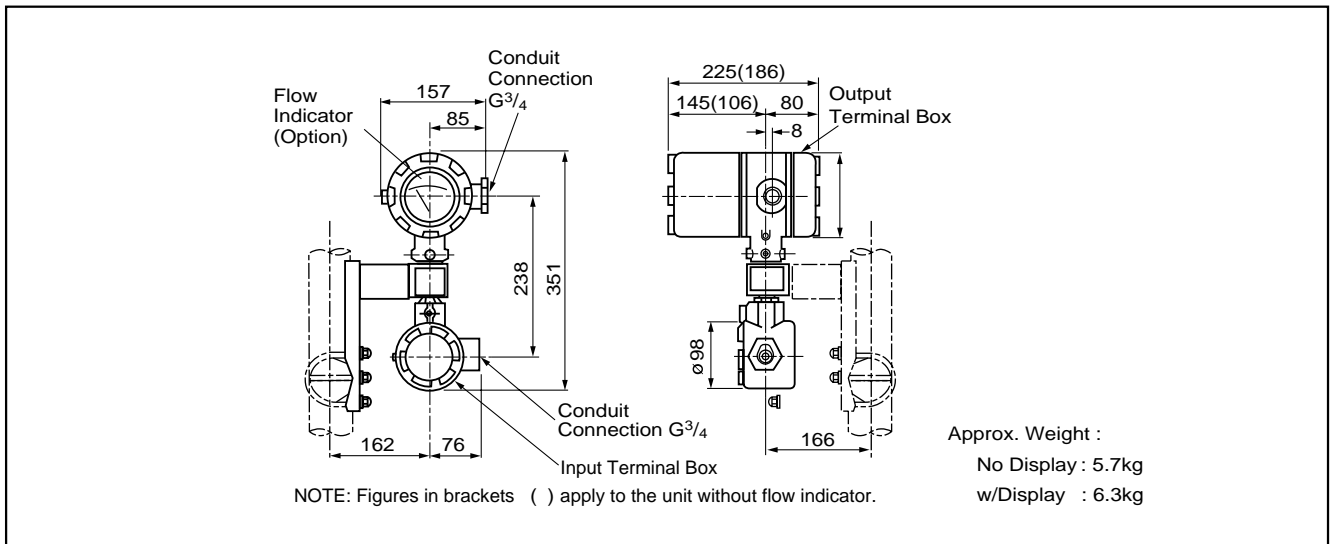

● Wiring connections

(Unit in mm)

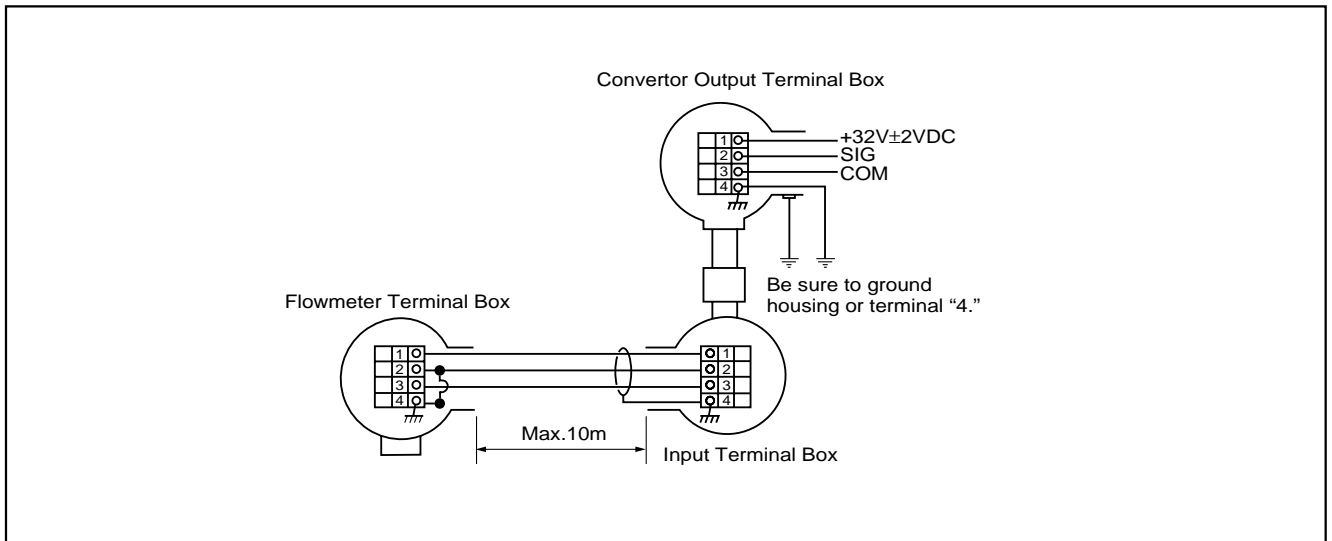

**HOOKUP WITH RECEIVING INSTRUMENTS**

**Actual Flow Totalization and Instantaneous Flow Indication**

Line temperature and pressure are considered approximately constant and correction factor can be multiplied as constant:

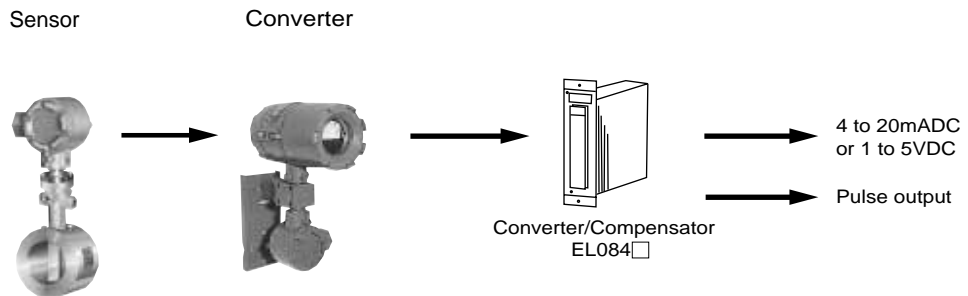
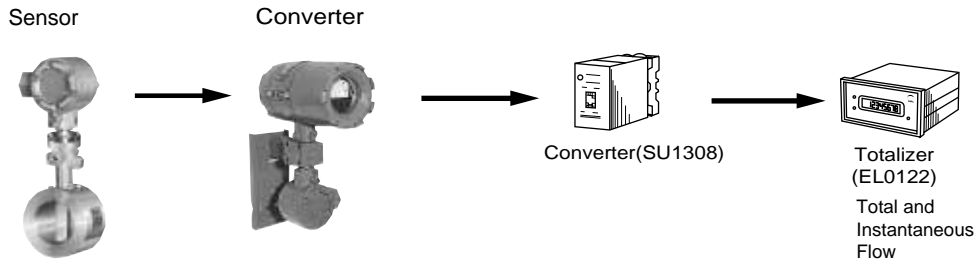

Line temperature and pressure are automatically compensated, and total and instantaneous flow readout (or output) are obtained:

Total Flow and Instantaneous Flowrate

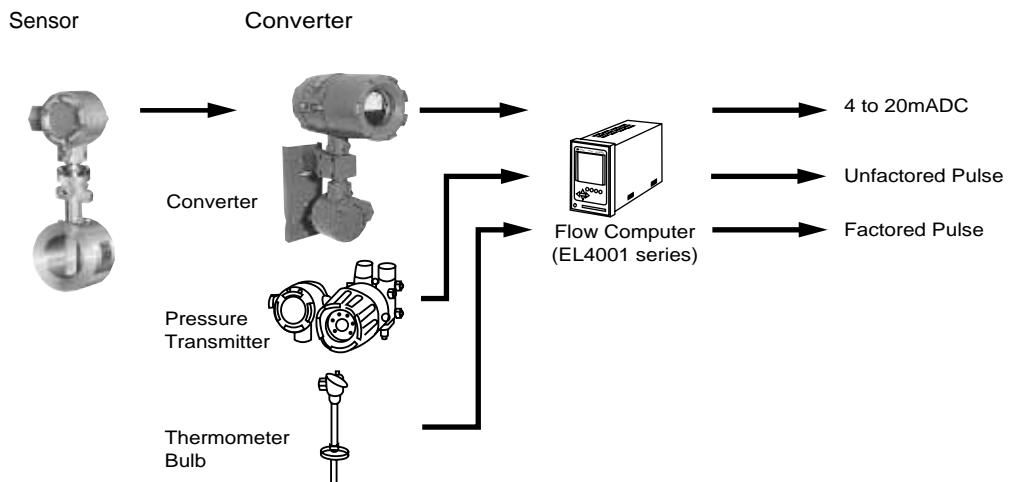

● A 32V DC power source is required for the preamplifier. In case of using a receiving instrument incapable of furnishing 32V DC, use OVAL pulse distributor Model SU1308.

● For details of individual receiving instruments, refer to respective general specification sheets.

## ■ PRODUCT CODE EXPLANATION (Standard type)

Item	Product Code															Description	
	①	②	③	④	⑤	⑥	⑦	⑧	⑨	⑩	⑪	⑫	⑬	⑭	⑮		
<b>Model</b>	<b>V</b>	<b>F</b>															Thermistor Type Delta Flowmeter
<b>Nominal size</b>			0	2	0												20mm ( $\frac{3}{4}$ " )
			0	2	5												25mm (1" )
			0	3	2												32mm (1 $\frac{1}{4}$ " )
			0	5	0												50mm (2" )
			0	8	0												80mm (3" )
			1	0	0												100mm (4" )
			1	5	0												150mm (6" )
			2	0	0												200mm (8" )
			2	5	0												250mm (10" )
			3	0	0												300mm (12" )
			4	0	0												400mm (16" )
		5	0	0												500mm (20" )	
<b>Style</b>						1											Flangeless (Nominal sizes 20 to 150mm)
						2											Flangeless, spigot joint type (Nominal sizes 25 to 150mm)
						3											Flanged
<b>Meter body material</b>																	D SUS304 (SCS13A)
																	G STPG370 (SB410)
<b>Pressure rating</b>							1	-									JIS 10K
							2	-									JIS 20K, ANSI 150
							3	-									JIS 30K, ANSI 300
<b>Bluff body material</b>																	D SUS304 (SCS13A)
<b>Sensor construction</b>																	1 Standard
																	5 Pressuretight seal (PTS) construction
<b>Converter construction</b>																	2 - Separate mounting (Non-explosionproof)
																	6 - Separate mounting (Explosionproof)
<b>Converter</b>																	1 1 Preamplifier for thermistor sensor (PA11)
<b>Local indication</b>																	0 Less local display
																	1 Local display provided
<b>Output signal</b>																	0 Output signal not required
																	1 Unfactored pulse output

## ■ PRODUCT CODE EXPLANATION (Gas purge type)

### ● Meter Body

Item	Product Code															Description
	①	②	③	④	⑤	⑥	⑦	⑧	⑨	⑩	⑪	⑫	⑬	⑭	⑮	
Model	V	F														Thermistor Type Delta Flowmeter
Nominal size		0	5	0												50mm (2")
		0	8	0												80mm (3")
		1	0	0												100mm (4")
		1	5	0												150mm (6")
		2	0	0												200mm (8")
		2	5	0												250mm (10")
		3	0	0												300mm (12")
		4	0	0												400mm (16")
	5	0	0												500mm (20")	
Process connection					1											Flangeless (Nominal sizes 50 to 150mm)
					2											Flangeless, spigot joint type (Nominal sizes 50 to 150mm)
					3											Flanged
Meter body material					D											SUS304 (SCS13A)
					G											STPG370 (STPY400)
Pressure rating					1	-										JIS 10K
Bluff body material									D							SUS304 (SCS13A)
Sensor construction										2						Gas purge type (room temp. service)
										3						Gas purge type (high and low temp. service)
Converter construction											2	-				Separately-mounted, non-explosionproof
											6	-				Separately-mounted, combined explosionproof
Preamplifier type												1	1			Preamplifier for thermistor sensor (PA11)
Local display														0		Less local display
														1		Local display provided
Output signal														0		Output signal not required
														1		Unfactored pulse output

### ● Purge Box

	Product code		Description
Purge box	FB01-		Pressure 19.6kPa [gauge] max.
	FB02-		Pressure 19.6kPa [gauge] min. (flow controller provided)
Purge fluid		1	Noninflammable gas, such as air and nitrogen
		2	Inflammable gas





**■ INSTALLATION CONDITIONS**

**1. TYPICAL PIPING INSTRUCTIONS**

It is generally required that the flow pattern of a fluid flowing in and out of an inferential type flow meter be as uniform as possible for higher accurate metering performance.

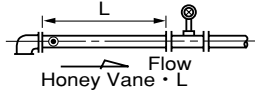
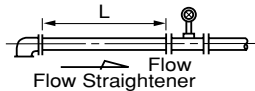
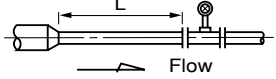
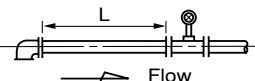
All account of this, proper flow straightening measures have to be applied for piping installation of EX DELTA. The standard piping instructions are shown in the following table.

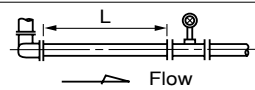
(1) Use an OVAL flow straightener or provide a specified straight pipe (ISO-5167 compliant).

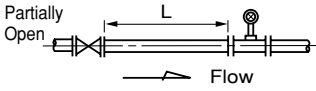
No.	Piping Arrangement	Straight Pipe Length(L)	Remark
1	 OVAL's Flow-Straightener Honey Vane	8D	Refer to P12  Applicable to Nominal size, >25mm
	 Flow Straightener	12D	
2	 Reducer	15D Min.	A concentric reducer is installed at the upstream of a meter.
3	 Elbow	23D Min.	An elbow is installed at the upstream of a meter.
		25D Min.	Two elbows are installed at the upstream of a meter.
		40D Min.	Two elbows are vertically installed at the upstream of a meter.
4	 Fully Open	15D Min.	A full-open gate valve is installed at the upstream of a meter.
5	 Partially Open	50D Min.	A partially open gate valve, sharp orifice or something that markedly disturbs the flow pattern is upstream of meter.

Note 1:Sch. 40 pipe is standard in the application above. Use Sch. 40 pipe for standard piping.

2:A short pipe section, 5D or longer shall be provided downstream of the meter.

3:For pressure detection, provide the probe downstream of the flowmeter (see figure below). To avoid disturbances in the flow, temperature detection should be made downstream of the flowmeter and, at the same time, upstream of the control valve.

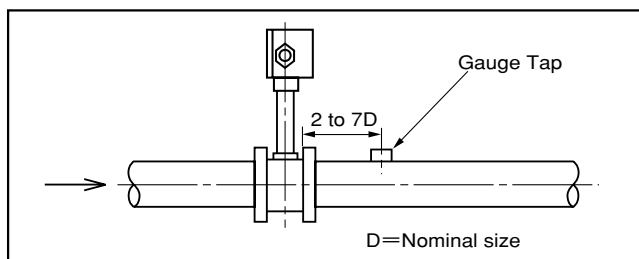

**● Installation of Honey Vane S**

- ① Locate the Honey Vane S upstream of the flowmeter.
- ② Provide a short pipe (8D or longer) between Honey Vane S and flowmeter.

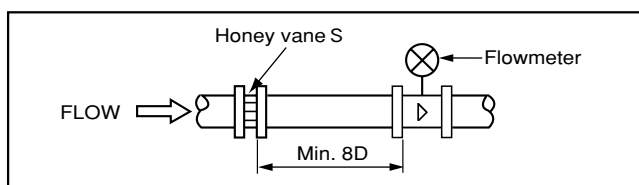

**2. Pressure fluctuation:**

In case EX DELTA is installed in the line where blower such as a roots blower and compressor those can generate fluctuated pressure, performance of the flowmeter can be affected by flow fluctuation. Allowable fluctuation pressure is calculated from the following equation.

$$N < 22 \rho V^2 \text{ (Pa)}$$

where, N : Fluctuation pressure (Pa)

$\rho$  : Density (kg/m<sup>3</sup>)

V : Min. Velocity (m/s)

Even at shutdown, pressure pulsation in the process fluid can produce a false output. If pressure pulsation is excessive, take the following measures:

- ① Locate the source of flow fluctuation downstream of the flowmeter.
- ② Install a pulsation attenuator.
- ③ At shutdown of the flow, shut off valves upstream and downstream of the flowmeter.
- ④ Provide a digital filter (to prevent false pulse output at shutdown).

## ● Honey Vane

### Outline Dimensions

Nom.size (mm)	∅D*1 (mm)	Honey Vane-S	Honey Vane-L
		t (mm)	L (mm)
25	75	3.5	200
40	90	5.4	320
50	105	6.9	400
80	134	10.2	640
100	159	13.3	800
150	220	19.6	1200
200	268	26	1600
250	331	32.3	2000
300	376	38.7	2400

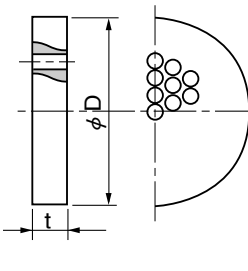

Honey Vane-S

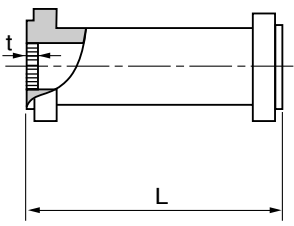

Honey Vane-L

\*1. JIS10K

## ■ ORDERING INSTRUCTIONS

Please fill out the following specifications when making inquiries.

Item	Description
1. Name of gas	
2. Flow range	Max. _____ Normal _____ Min. _____ <input type="checkbox"/> m <sup>3</sup> /h [normal] <input type="checkbox"/> m <sup>3</sup> /h [actual]
3. Temp. range	Max. _____ Normal _____ Min. _____ °C
4. Press. range	Max. _____ Normal _____ Min. _____ <input type="checkbox"/> MPa [gauge]
5. Density or sp. gr.	Density _____ <input type="checkbox"/> kg/m <sup>3</sup> [normal], <input type="checkbox"/> kg/m <sup>3</sup> [actual] Sp. Gr. _____
6. Viscosity	_____ <input type="checkbox"/> mPa·s, <input type="checkbox"/> mm <sup>2</sup> /s at _____ °C
7. Connections	Nominal size _____ <input type="checkbox"/> mm, <input type="checkbox"/> ", Flange rating <input type="checkbox"/> JIS _____ K <input type="checkbox"/> FF <input type="checkbox"/> ANSI _____ RF <input type="checkbox"/> RF
8. Flow straightening pipe	<input type="checkbox"/> Req'd (Flow straightener and downstream pipe) <input type="checkbox"/> Not req's (Prepare a straight pipe of specified length, I.D., Sch. No.)
9. Local indication	<input type="checkbox"/> Req'd <input type="checkbox"/> Not req'd
10. Compensation	<input type="checkbox"/> Temp. and Press. <input type="checkbox"/> Pressure <input type="checkbox"/> Temperature
11. Compensation range	Temp. _____ to _____ °C, Pressure _____ to _____ MPa [gauge]
12. Compensation ref.	Ref. temp. _____ °C Press. ref. _____ MPa [gauge]
13. Compensation coeff.	
14. Accuracy test	<input type="checkbox"/> Req'd <input type="checkbox"/> Not Req'd
15. Receiving instrument	<input type="checkbox"/> Totalizer <input type="checkbox"/> Indicator <input type="checkbox"/> Indicator recorder <input type="checkbox"/> Others ( )
16. Miscellaneous	

The specification as of May, 2009 is stated in this GS Sheet. Specifications and design are subject to change without notice.



**Sales Representative:**  
**icenta CONTROLS Ltd**  
 North Station Yard, Warminster Road, Wilton, Salisbury, SP2 0AT  
 Tel: 0845 895 1020 Fax: 0845 895 1021  
 Email: sales@icenta.co.uk  
 www.icenta.co.uk

GS.No.GBD101E

初版	改訂	印刷
81.5	09.5	