

DMD 341

Differential Pressure Transmitter for gases and compressed air in compact version

- ▶ piezoresistive silicon sensor
- ▶ compact and robust aluminium housing
- ▶ differential pressure from 0 ... 6 mbar up to 0 ... 1000 mbar

The DMD 341 is a differential pressure transmitter for non-aggressive gases and compressed air. Because of its compact and robust aluminium housing it is particularly suited for machine and plant engineering.

Basic element of the DMD 341 is a piezoresistive silicon pressure sensor, which features high accuracy and excellent long term stability.

In combination with our display and switching unit ASM 430 the user stands by the 4-digit LED-display for representing the differential pressure as well as up to 2 freely configurable contacts. The DMD 341 offers high flexibility with regard to mounting as well as mechanical and electrical connection.

The display is rotatable so that clear readability is guaranteed even on unusual installation positions.

Applications:

- ▶ filter controlling
- ▶ air conditioning technology

- ▶ gauge and differential pressure measurement
- ▶ for non-aggressive gases and compressed air
- ▶ current and voltage output signals in 2- and 3-wire systems
- ▶ excellent long term stability
- ▶ compact design
- ▶ mechanically robust
- ▶ option: display and switching module with up to 2 contacts
- ▶ customer specific versions on request

Characteristics



DMD 341
Differential Pressure Transmitter

DMD 341

Differential Pressure Transmitter

Technical Data

Input pressure range

Nominal pressure P_N [mbar] (gauge and differential pressure)	6	10	20	40	60	100	160	250	400	600	1000
Permissible overpressure [mbar]	100	100	200	350	350	1000	1000	1000	1000	3000	3000

Output signal / Supply

Standard	2-wire:	4 ... 20 mA	/ $V_s = 12 \dots 36 V_{DC}$
Optional	3-wire:	0 ... 20 mA	/ $V_s = 14 \dots 36 V_{DC}$
		0 ... 10 V	/ $V_s = 14 \dots 36 V_{DC}$

Performance

Accuracy	$P_N > 160$ mbar: 40 mbar $\leq P_N \leq 160$ mbar: $P_N < 40$ mbar:	IEC 60770 ¹	BFSL
		$\leq \pm 0.35$ % FSO	$\leq \pm 0.175$ % FSO
Permissible load	current 2-wire:	$R_{max} = [(V_s - V_{smin}) / 0.02] \Omega$	
	current 3-wire:	$R_{max} = 500 \Omega$	
	voltage 3-wire:	$R_{min} = 10 k\Omega$	
Influence effects	supply:	0.05 % FSO / 10 V	
	load:	0.05 % FSO / k Ω	
Long term stability	$\leq \pm 0.2$ % FSO / year		
Response time	< 5 msec		

Thermal errors (Offset and Span)

Nominal pressure P_N [mbar]	≤ 10	≤ 20	≤ 250	> 250
Tolerance band [% FSO]	$\leq \pm 2$	$\leq \pm 1.5$	$\leq \pm 1$	$\leq \pm 0.5$
TC, average [% FSO / 10 K]	± 0.3	± 0.25	± 0.15	± 0.08
in compensated range [°C]	0 ... 60			

Electrical protection

Short-circuit protection	permanent
Reverse polarity protection	no damage, but also no function
Electromagnetic compatibility	emission and immunity according to EN 61326

Mechanical stability

Vibration	10 g RMS (20 ... 2000 Hz)
Shock	100 g / 11 msec

Permissible temperatures

Media	-25 ... 125 °C
Electronics / environment	-25 ... 85 °C
Storage	-40 ... 100 °C

Display and switching unit (optional)

Technical data of display and switching unit see data sheet ASM 430

¹ accuracy according to IEC 60770 – limit point adjustment (non-linearity, hysteresis, repeatability)

DMD 341

Differential Pressure Transmitter

Technical Data

Mechanical connection

Standard

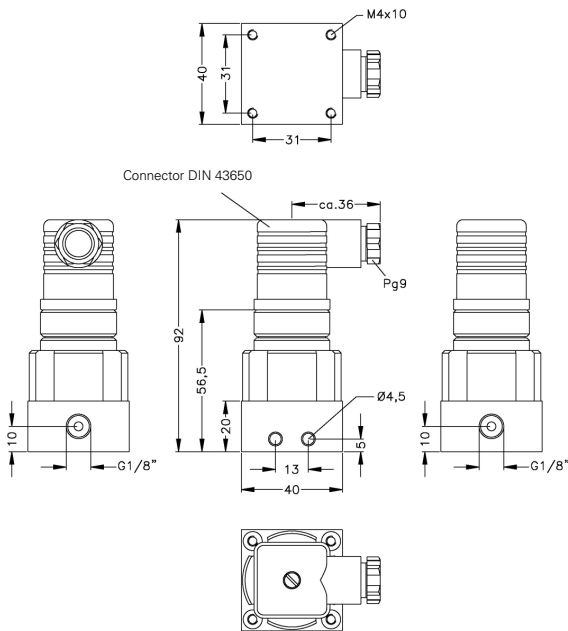

G1/8" internal

Version with ASM 430

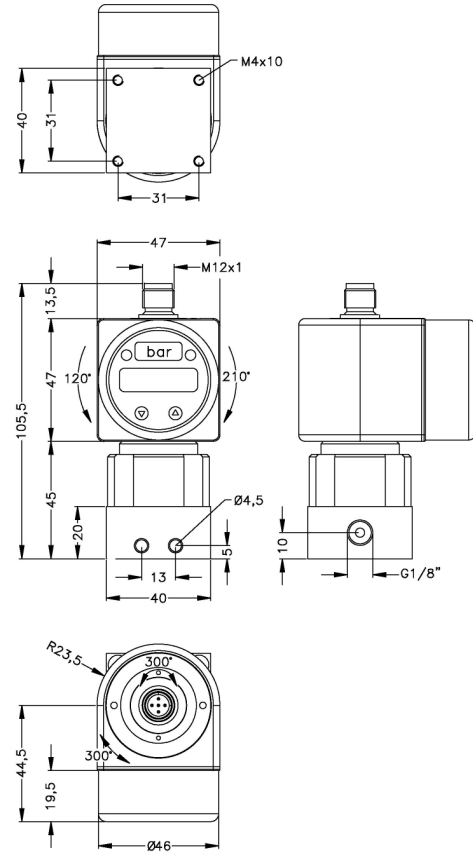

G1/8" internal with display and switching module ASM 430

Electrical connection

Standard

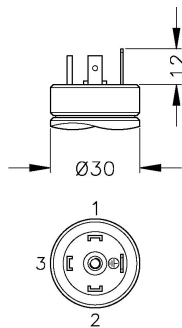

DIN 43650 (IP 65)

Optional

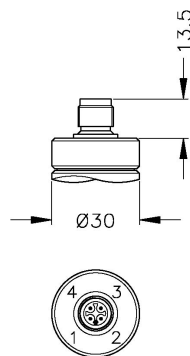

M12x1 4-pin (IP 67)

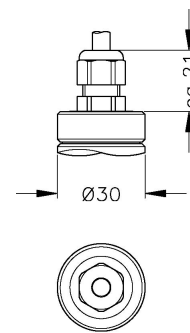

Cable gland (IP 67)²

² different cable types and lengths available; standard: 2 m PVC cable without ventilation tube, optionally cable with ventilation tube

DMD 341

Differential Pressure Transmitter

Technical Data

Materials

Pressure port	G1/8" internal: aluminium, silver anodised flexible tube connection Ø6.6 x 11: brass, nickel plated
Housing	aluminium, silver anodised
Seals (media wetted)	PUR, bonded
Sensor	silicon, glass, RTV, ceramics Al ₂ O ₃ , nickel
Media wetted parts	pressure port, housing, seals, diaphragm

Miscellaneous

Cable capacitance ³	cable without air tube: signal line/shield: 160 pF/m cable with air tube: signal line/shield: 150 pF/m	signal line/signal line: 120 pF/m signal line/signal line: 100 pF/m
Cable inductance ³	cable without air tube: signal line/shield: 0.65 µH/m cable with air tube: signal line/shield: 1.0 µH/m	signal line/signal line: 0.65 µH/m signal line/signal line: 1.0 µH/m
Current consumption	signal output current: max. 25 mA signal output voltage: max. 7 mA	
Weight	approx. 250 g	
Operational life	> 100 x 10 ⁶ cycles	

Pin configuration

Electrical connection		DIN 43650	M12x1 (4-pin)	cable colours ³ (DIN 47100)
2-wire-system	Supply +	1	1	white
	Supply -	2	2	brown
	Ground	ground pin	4	yellow / green (shield)
3-wire-system	Supply +	1	1	white
	Supply -	2	2	brown
	Signal +	3	3	green
	Ground	ground pin	4	yellow / green (shield)

Wiring diagrams

2-wire-system (current)

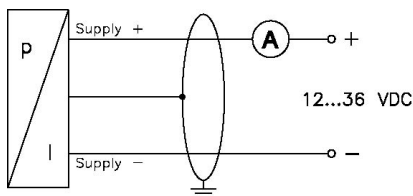

3-wire-system (current)

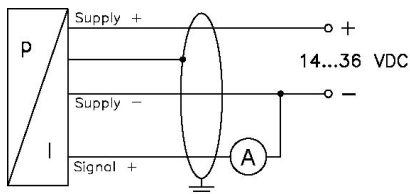

3-wire-system (voltage)

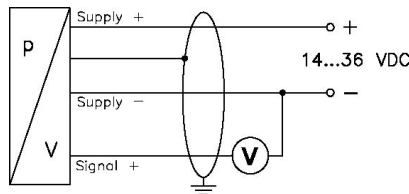

³ if the electrical connection is a mounted cable by factory