



ECO OVAL

METER SIZES:29, 60
(Single-case Construction)

GENERAL SPECIFICATION
GS.No.GBB352E-3

■ GENERAL

The two big words "ecology" and "economy" were inseparable in developing the ECO OVAL series PD meters. Backed by the expertise and experience gained over the years, the latest additions to this series are competitively priced models in explosionproof construction. Typical applications of these general-purpose flowmeters include metering oils. They come in two types; battery powered, dedicated to the local indicator and externally powered with a built-in pulse generator.

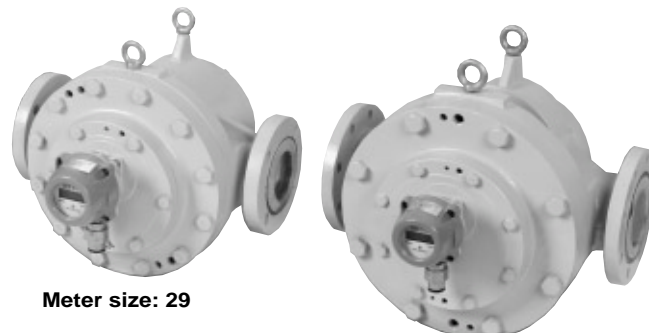

Meter size: 29

Meter size: 60

■ FEATURES

1. Outstanding accuracy

Operates on the proven oval rotor principle, ensuring high accuracy.

2. Simple construction

A pair of oval rotors are the only components present in

the measuring chamber. They are easily accessible for maintenance, too.

3. Very a affordable price and short delivery.

■ GENERAL SPECIFICATIONS

Item	Description	
Meter size	29	60
Nominal size, mm	80mm (3")	100mm (4")
Flange rating	ASME 150 RF (Standard) · JIS 10K RF (Option)	
Flange face to face dimension	444 (ASME) · 440 (JIS)	532 (ASME · JIS)
Linearity	±0.35% (Standard), ±0.15% (Option)	
Applicable fluid	Gasoline, kerosene, light oil, heavy oil (200mPa·s and lower)	
Flow range	See flow range table (page 2).	
Max. operating pressure	1.18MPa	
Operating temp. range	0 to 60°C (Standard), 0 to 120°C (Explosionproof model : 0 to 100°C) (Option)	
Construction	Single-case construction, Simple magnetic coupling system "5"	
Material	Body : FC250, Rotors : FC250, Rotor shafts : SUS304, Rotor bearings : OB414, Signal magnets : SMC	
Finish	Munsell 2.5G8/2	
Register	ECO OVAL register	
Register display	Select one from accumulated total (8- digit), instant flowrate (m ³ /h or m ³ /min), and resettale total (7-digit).	
Output signal	None (local display only)	
	Factored/unfactored pulse output (externally powered model only)	
	Type : Open collector pulse Capacity : Allowable current: 20mADC Max. impressed voltage: 30VDC See factored pulse units, pulse width selection table (page 2).	
Explosionproof configuration	TIIS NEPSI	Battery powered: Intrinsically safe explosionproof Exia II BT4 External power: Flameproof and intrinsically safe ex. Exd II BT4/Exia II BT4 (※1)
	ATEX	Battery powered: Intrinsically safe explosionproof II 2G EExia II BT4 External power: Flameproof safe explosionproof II 2G Exd II BT4
Housing protection grade	IP66	
Pulse rate	12P/REV	
Nom. meter factor	198.62mL/p	338.9mL/P
Strainers	SR081B031 (40 mesh)	SR101B031 (40 mesh)

※1 : Externally powered model operates with or without external power. Rated flameproof when externally powered; rated intrinsic safety when powered from an internal battery

※ : This meter is not provided with subtract counter. In an application where flow pulsation (flowrate is unstable and fluctuates by effect of pressure) and reverse flow exist, pulses are all added up irrespective of flow direction, resulting in inconsistent total counter reading.

■ APPLICABLE EN DIRECTIVES

Applicable EU Directive	Electro-Magnetic Compatibility Directive : 2004/108/EC ATEX Directive : 94/9/EC
Applicable EN standards, etc.	For Electro-Magnetic Compatibility Directive EN55011 : 1998/A1 : 1999, Group 1, Class B EN61000-6-2 : 2001 ATEX Directive : EN 60079-0:2006 EN 60079-1:2007 EN 50020:2002

OVAL Corporation

<http://www.oval.co.jp>

Head Office (Tokyo): Phone. 81-3-3360-5121. Fax. 81-3-3365-8605
Beijing Office: Phone. 86-10-5867-4711. Fax. 86-10-5867-4713
Overseas Branch Offices: Seoul, Singapore and Taipei

■ FLOW RANGES

● **Table A Flow Range for General Liquids (Linearity : ±0.35%)**

Unit in m³/h

Meter Size	Nom. size mm	Operating condition	Viscosity range			
			0.3mPa·s to 0.8mPa·s	0.8mPa·s to 2mPa·s	2mPa·s to 5mPa·s	5mPa·s to 200mPa·s
29	80	Continuous	10 to 50	8 to 50	6 to 70	4 to 70
		Intermittent	10 to 70	8 to 70	6 to 90	4 to 90
		A.I.F.	90	90	90	90
60	100	Continuous	20 to 85	15 to 85	8 to 120	5 to 120
		Intermittent	20 to 125	15 to 125	8 to 150	5 to 150
		A.I.F.	150	150	150	150

● **Table B Flow Range for General Liquids (Linearity : ±0.15%)**

Unit in m³/h

Meter Size	Nom. size mm	Temp. bracket	Operating condition	Viscosity range			
				0.3mPa·s to 0.8mPa·s	0.8mPa·s to 2mPa·s	2mPa·s to 5mPa·s	5mPa·s to 200mPa·s
29	80	Up to 60°C (Standard)	Continuous	15 to 50	13 to 50	9 to 70	6 to 70
			Intermittent	15 to 70	13 to 70	9 to 90	6 to 90
			A.I.F.	90	90	90	90
		Up to 120°C	Continuous	22 to 45	19 to 45	13 to 63	9 to 63
			Intermittent	22 to 63	19 to 63	13~81	9 to 81
			A.I.F.	81	81	81	81
60	100	Up to 60°C (Standard)	Continuous	30 to 85	25 to 85	12 to 120	8 to 120
			Intermittent	30 to 125	25 to 125	12 to 150	8 to 150
			A.I.F.	150	150	150	150
		Up to 120°C	Continuous	45 to 76	37 to 76	18 to 100	12 to 100
			Intermittent	45 to 110	37 to 110	18 to 130	12 to 130
			A.I.F.	130	130	130	130

NOTES: In the Operating Condition column "Continuous" means continuous operation; "Intermittent" means no more than 8 hours operating a day, and "A.I.F." indicates allowable instantaneous flow rate.

■ FACTORED PULSE WIDTH SELECTOR TABLES

: Option

Meter Size	Capacity	Factored pulse		Factored pulse selectable range				Unfactored pulse	
		Unit pulse	Output freq., Hz	1ms	50ms	100ms	250ms	Nom. meter factor	Output freq.
29	99999.999 ×m ³	1L/P	25 Hz	○	—	—	—	199.8 mL/P	125.1 Hz
	999999.99 ×m ³	10L/P	2.5 Hz	○	○	○	—		
	9999999.9 ×m ³	100L/P	0.25 Hz	○	○	○	○		
60	99999.999 ×m ³	1L/P	41.6 Hz	○	—	—	—	338.9 mL/P	106.5 Hz
	999999.99 ×m ³	10L/P	4.16 Hz	○	○	—	—		
	9999999.9 ×m ³	100L/P	0.41 Hz	○	○	○	○		

■ METER ERRORS and PRESSURE LOSSES

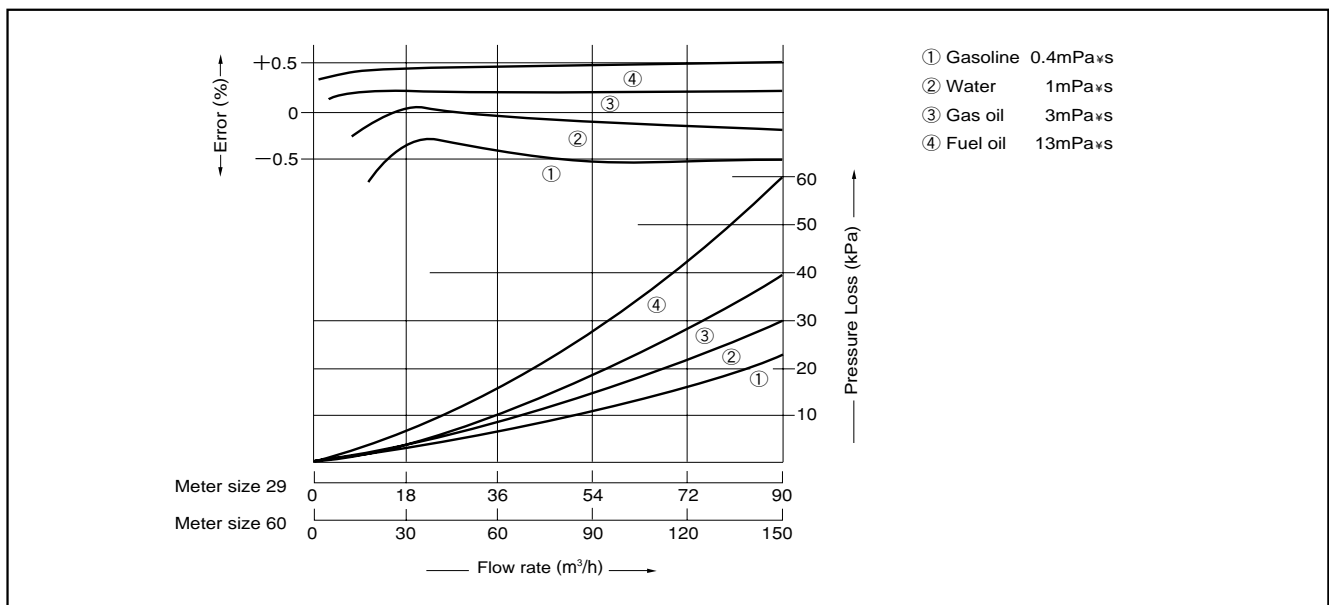

■ HOOKUP WITH RECEIVING INSTRUMENTS

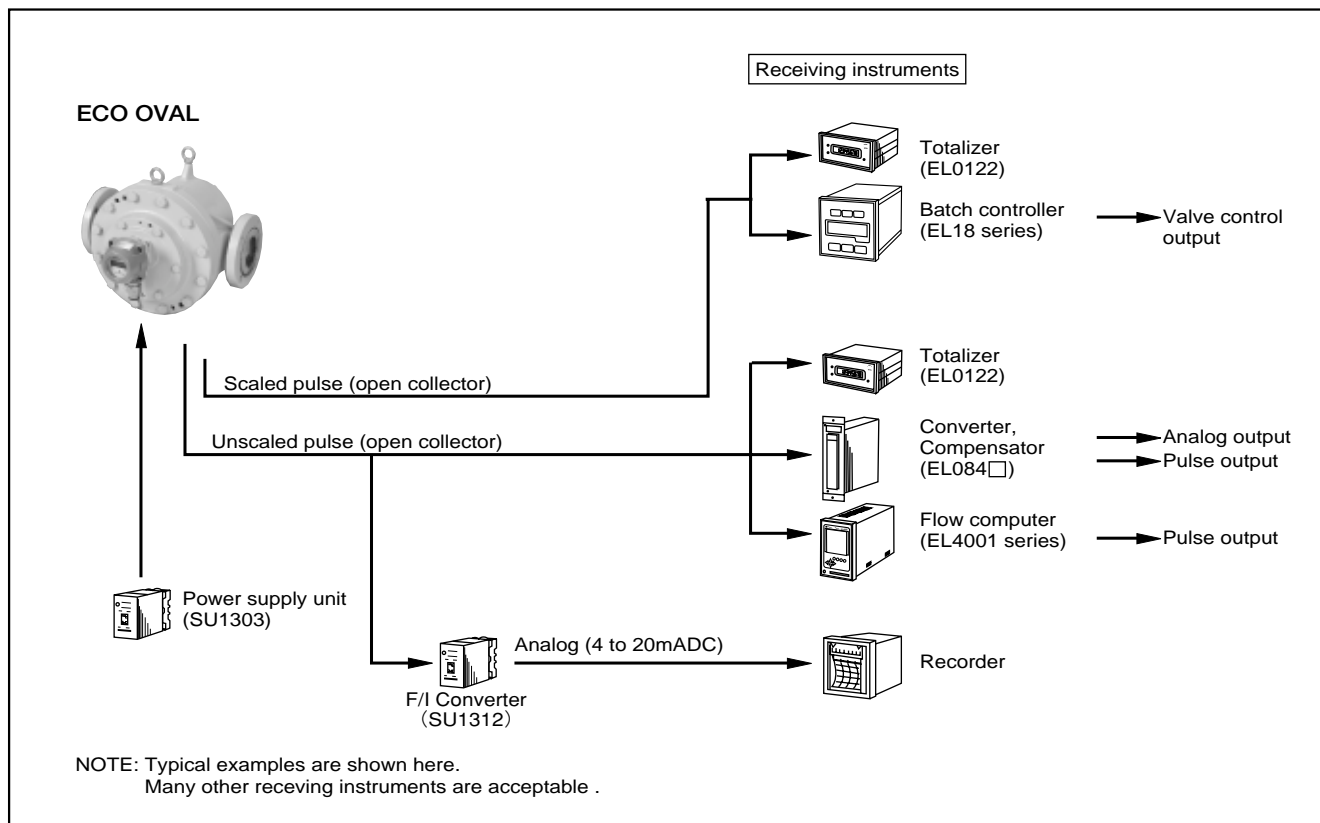

■ PRODUCT CODE EXPLANATION

Item	Code No.												Description	
	①	②	③	④	⑤	⑥	⑦	⑧	⑨	⑩	⑪	⑫		
Type	L	G												ECO OVAL
Meter ID code	B													Meter body: Cast Iron (FC250) Rotors : FC250
Meter size	2	9												Nominal size 3B (80mm)
	6	0												Nominal size 4B (100mm)
			A											Always "A"
Flange rating														1 JIS 10 K RF (Option)
														2 ASME 150 RF (Standard)
Max. Operating temp. and Linearity														0 Max. Operating temp. 60°C • Linearity ±0.35% (Standard)
														1 Max. Operating temp. 60°C • Linearity ±0.15% (Option)
														2 Max. Operating temp. 120°C • Linearity ±0.35% (Option)
														3 Max. Operating temp. 120°C • Linearity ±0.15% (Option)
														-
Power source														D Battery powered (without pulse generator)
														G Externally powered
Explosionproof ratings CE marking														0 Non-explosionproof
														1 TIIS Explosionproof, Battery powered: Exia II BT4, Externally powered: Exd (ia) II BT4
														2 ATEX /Battery powered: II 2G EExia II BT4, External power: II 2G Exd II BT4
														7 NEPSI /Battery powered: Exia II BT4, External power: Exd II BT4/ Exia II BT4
Generator type														0 Less pulse generator
														3 Open collector factored pulse(pulse width 1ms), unfactored pulse (pulse Width 1ms)
														5 Open collector factored pulse(pulse width 10ms), unfactored pulse (pulse Width 1ms)
														6 Open collector factored pulse(pulse width 50ms), unfactored pulse (pulse Width 1ms)
														7 Open collector factored pulse(pulse width 100ms), unfactored pulse (pulse Width 1ms)
														0 Always "0"

■ **OUTLINE DIMENSIONS** [Unit in mm]

● **Meter size: 29**

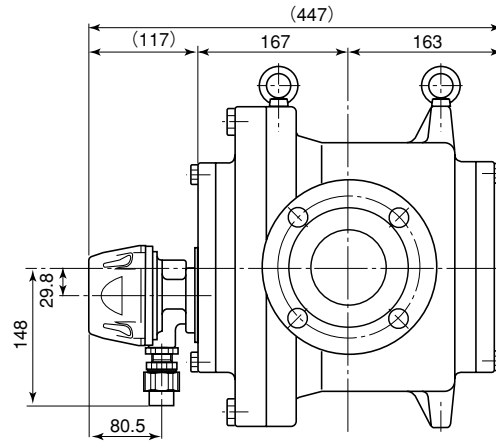
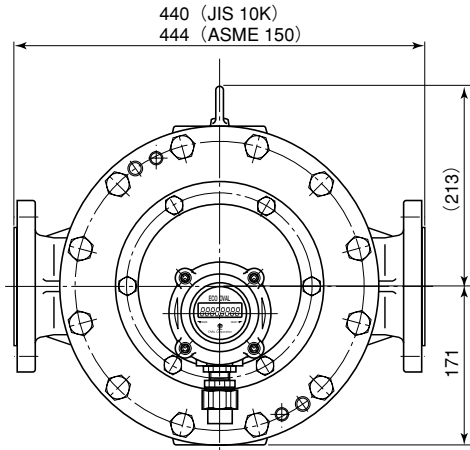

● **Meter size: 60**

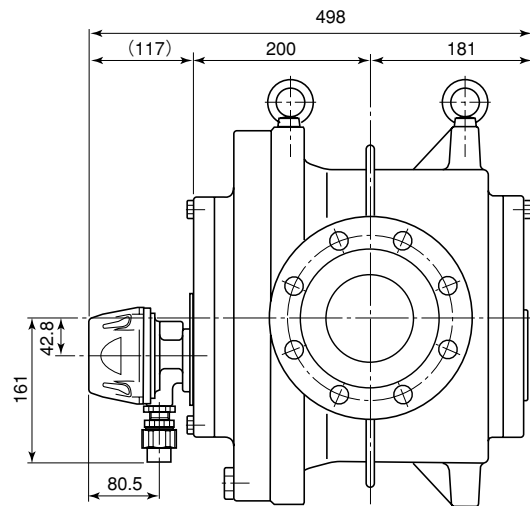
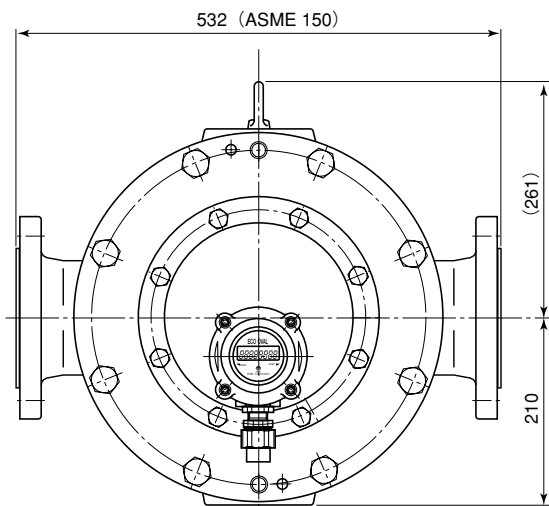

■ WIRING DIAGRAM

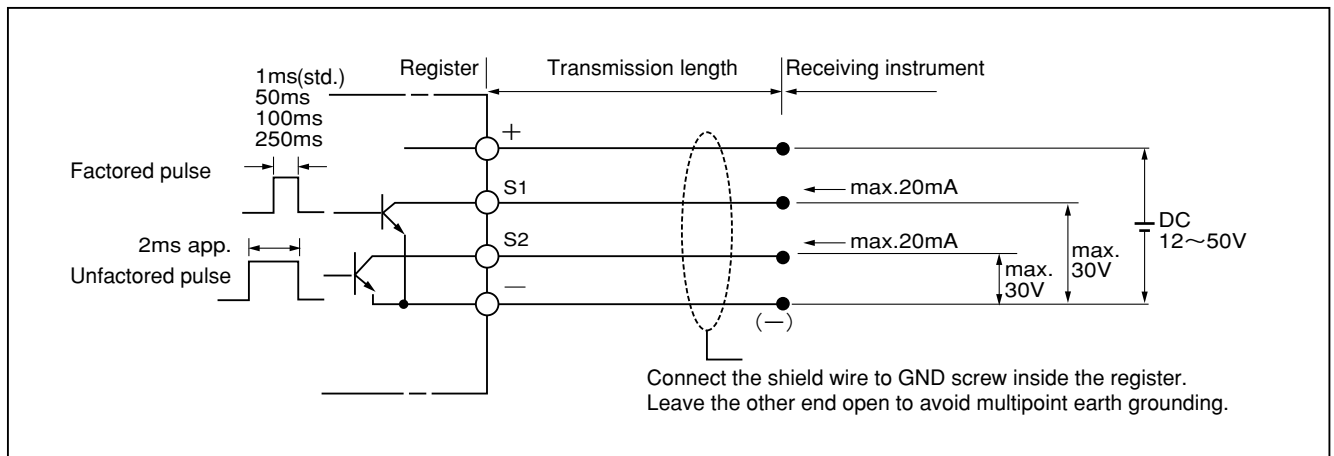

For reference an arrangement to convert open collector pulse into voltage pulse is shown.

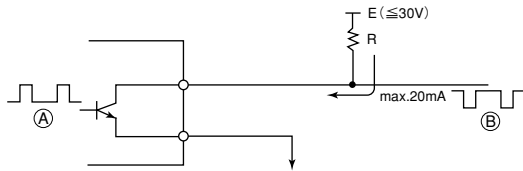

NOTE: Select load resistance value R such that the current flowing into the transistor is held below 20mA in relation with E. Waveforms (A) and (B) are inverted to each other.

Precautions

1. Both factored pulse and unfactored pulse output are of open collector output. Make sure to have a load on the part of receiving instrument that the rate is held within 30VDC, 20mA max.
2. Exercise care to avoid exceeding the rating or incorrect wiring connections with regard to polarities that could result in damage to the register.
3. Depending on the type of cable, select either unfactored or factored pulses.

■ ORDERING INFORMATION

Please complete the following form when making inquiries.

1. Model	L_____
2. Fluid to be measured	Name_____ Viscosity_____mPa·s Specific gravity_____
3. Flowrate (L/h, m ³ /h)	Maximum_____ Normal_____ Minimum_____
4. Fluid temperature (°C)	Maximum_____ Normal_____ Minimum_____
5. Ambient temperature (°C)	Maximum_____ Normal_____ Minimum_____
6. Pressure (MPa)	Maximum_____ Normal_____ Minimum_____
7. Flow direction	Right ⇌ Left, Bottom ⇌ Top
8. Flange connection	Nominal size_____mm, Flange rating_____
9. Required Linearity	±_____%
10. Explosionproof construction	<input type="checkbox"/> Required class_____ <input type="checkbox"/> Not required
11. Accessories	<input type="checkbox"/> Strainer, <input type="checkbox"/> Companion flange
12. Quantity	Including accessories_____
13. Application	_____(dosing, sampling, blending process, etc.) <input type="checkbox"/> Flow integration, <input type="checkbox"/> Flow indication, <input type="checkbox"/> Record, <input type="checkbox"/> Flow control, <input type="checkbox"/> Batch control, <input type="checkbox"/> CPU interface, <input type="checkbox"/> Others
14. Receiving instrument	Type, manufacturer, model, specifications (input, output, power supply, etc.)
15. Distance between flow meter and receiving instrument	_____m

The specifications as of Dec., 2010 are stated in this GS Sheet. Specifications and design are subject to change without notice.



Sales Representative:
icenta CONTROLS Ltd
North Station Yard, Warminster Road, Wilton, Salisbury, SP2 0AT
Tel: 0845 895 1020 Fax: 0845 895 1021
Email: sales@icenta.co.uk
www.icenta.co.uk

GS.No.GBB352E

初版	改訂	印刷
07.5	10.12	08.05