



Excellent Vortex Flowmeter INSERTION Type BATTERY POWERED EX DELTA

GENERAL SPECIFICATION
GS.No.GBD604E-6

■ GENERAL

The battery-powered EX DELTA is a dedicated on site monitor with a wide variety of applications as a universal vortex flowmeter. It has been designed to be simple to use on the built-in battery alone.

The display monitors integrated value or instantaneous flow and is switchable externally. A remote display unit is also available that allows the display to be installed up to 200m away from several dispersed sensors. This flowmeter is in preparation of a fixed type and a hot-tap type.

■ FEATURES

1. Offers high accuracy measurement over a wide flow-range.
2. Applicable for flow measurement of gas, liquid and steam.
3. The sensor, completely isolated from wetted parts, has along service life.
4. Absence of any moving parts means that dust and mist in the medium being measured are less likely to pose a problem.
5. Battery powered converter without external power supply requires no wiring configuration. The battery unit composed of 5 pcs of lithium batteries in the converter allows continuous service for 7 years in case of integral type converter and for 4 years in case of separated type converter.
6. Totalizer flow (cumulative and resettable) and instantaneous flow rate can be monitored by digital display.

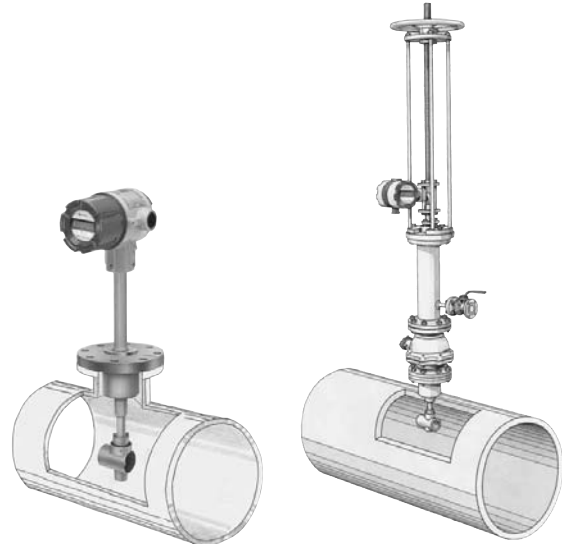

Fixed Type

Hot-tap Type

7. Water proof (IP65) and intrinsically safety (Exia II CT4) construction are the most suitable to local flow monitoring sensor.
8. The separate type is able to monitor up to 200m away from several dispersed sensors.

■ GENERAL SPECIFICATIONS

Item	Description	
Mounting Type	Fixed Type	Hot-tap Type
Nominal Size to be applied	200, 250, 300, 400, 500, 600, 800, 1000, 1500, 2000mm	400, 500, 600, 800, 1000, 1500, 2000mm
Nominal Size of the Probe	50mm	
Mounting Flange	100mm (4")	
Pressure Rating	JIS 10K, ANSI/JPI 150	
Standard Insertion Depth	Nominal Size of Piping: D<500mm; 0.5D D≥500mm; 0.2D D=Inner Dia.of Piping(mm)	
Fluid to be Metered	Liquids (Water. Hot Water. Chemical Liquids) Gases (Oxygen. Nitrogen. Carbon Dioxide. Compressed Air. etc.) Steam (Saturated Steam. Super Heated Steam)	
Flow range	See flow range table P2, P3, P4	
Velocity Range	Air (Atm. press.): 12 to 50m/s Water : 0.6 to 6m/s	
Operating Tem. Range (※1)	-10 to +300°C	
Max. Operating Pres. (※2)	Depends on flange rating	
Accuracy	Within ±2% of FS	
Materials	Meter Body	Stainless Steel (SUS304)
	Bluff Body	Stainless Steel (SUS304)
Installation	Horizontal or Vertical	Horizontal

※1 : Operating temperature range depends on condition of the fluid to be measured.

※2 : Accuracy shall be guaranteed only for the specified actual nominal size.

OVAL Corporation

<http://www.oval.co.jp>

Head Office (Tokyo): Tel. 81-3-3360-5121. Fax. 81-3-3365-8605
Beijing Office: Tel. 86-10-5867-4711. Fax. 86-10-5867-4713
Overseas Branch Offices: Seoul, Singapore and Taipei

CONVERTER SPECIFICATIONS

Item	Description
Model	PA35
Mounting	Select any one of the following types: 1. Integrated with a meter 2. Separated type with 2" pipe stand (※1)
Display	LCD: Indication of Totalizing, Instantaneous Flowrate (Lettr height : 10mm) <ul style="list-style-type: none"> • Totalizing Counter, 8 digits • Instant. Flow rate (/ h) : b1 • Instant. Flow rate (/ min) : b2 • Reset counter, 7 digits : C Select by a external switch (Display is rotatable at 90° steps.) Low battery alarm with flisketing mark
Power Supply	Unified cassette with 5 pieces of a 3.6V lithium dry battery : Life: 7 years continuous (for Integral type) : 4 years continuous (for separate type)
Explosionproof	Intrinsically safety (ExiallCT4)
Water-proof	JIS C 0920 jet-proof (IEC IP65)
Operating Temperature	Ambient -20 to +60°C Refer to right diagram
Ambient Humidity	5 to 100% R.H (without dew condensation)
Housing Material	Aluminum alloy
Housing Finish	Finished in baked melamine Finish Munsell 2.5G8/2 (Cover: Munsell 2.5BG5/6)

(※1) : distance between a meter and a converter: Max. 200m.

Ambient Temperature Range

If the fluid temperature exceed 125°C, the allowable ambient temperature range reduces as shown in the diagram below.

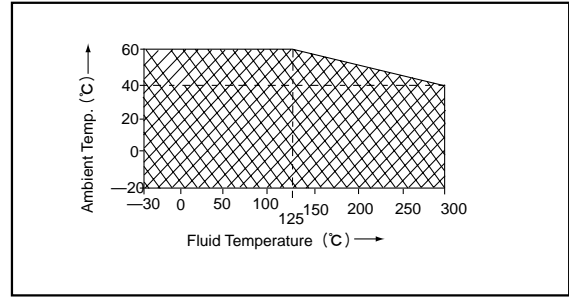

Nominal Meter Factor

Nominal Size of Piping mm (inch)	Nominal Meter Factor L/p
200 (8)	2.42
250 (10)	3.89
300 (12)	5.75
400 (16)	10.7
500 (20)	18.9
600 (24)	27.7
800 (30)	49.2
1000 (40)	76.9
1500 (60)	173
2000 (80)	309

FLOW RANGE

Table A, B, C, E are given value calculated from a nominal bore size. In order to determine flow range for actual piping bore size, correction should be made according to the following equation.

$$Q = Q_0 \times (D/D_0)^2 \dots \dots [A]$$

- Q :Flow rate based on actual bore size.
- Q₀:Flow rate based on nominal bore size.
- D :Actual bore size.
- D₀:Nominal bore size.

Flow Range for Liquid in General

Select the minimum flow rate from Table A (based on specific gravity) or Table B (based on viscosity), whichever is greater.

Table A: Calculated value from specific gravity

Unit : m³/h

Nominal Size mm (inch)	Sp.Gr. Velocity (m/s)	Minimum Flow Rate							Maximum	
		0.5	0.6	0.7	0.8	0.9	1.0	1.1		1.2
200 (8")	0.90	102	93	86	80	76	72	69	66	678
250 (10")		158	145	134	125	118	112	107	102	1060
300 (12")		228	208	193	180	170	161	154	147	1520
400 (16")		405	370	342	320	302	287	273	262	2710
500 (20")		633	578	535	500	472	447	427	409	4240
600 (24")		911	831	770	720	679	644	614	588	6100
800 (32")		1620	1480	1370	1280	1210	1150	1100	1050	10800
1000 (40")		2530	2310	2140	2000	1890	1790	1710	1640	16900
1500 (60")		5690	5200	4810	4500	4250	4030	3840	3680	38100
2000 (80")		10200	9240	8550	8000	7540	7160	6820	6530	67800

Table B: Calculated value from viscosity

Unit : m³/h

Nominal Size mm (inch)	Kinematic Viscosity (mm ² /s) Velocity (m/s)	Minimum Flow Rate									
		1	2	3	5	10	15	20	25	30	40
200 (8")	0.13	0.26	0.39	0.65	1.30	1.95	2.60	3.25	3.90	5.20	
250 (10")				45	74	147	221	294	368	441	589
300 (12")				69	115	230	345	460	575	690	919
400 (16")				100	166	331	497	662	827	993	1330
500 (20")				177	294	589	883	1180	1470	1770	2360
600 (24")				276	460	919	1380	1840	2300	2760	3680
800 (32")				397	662	1330	1990	2650	3310	3970	5300
1000 (40")				706	1180	2360	3530	4710	5890	7060	9410
1500 (60")				1110	1840	3680	5520	7360	9190	11100	14700
2000 (80")				2490	4140	8270	12400	16600	20700	24900	33100
				4410	7360	14700	22100	29400	36800	44100	58900

● Flow Range for General Gases

In this table, flow rates are specified in [actual] base. Therefore, in case of [normal] base, make it sure to convert the flow rate to [actual] condition and determine the flow range and the nominal diameter based on this table.

How to Determine the Minimum Flow Rate

Find a value D, follow the same column upwards and find a value intersecting the desired diameter in Table C for the minimum flow rate.

Table C&D

Nominal Size mm (inch)	Density kg/m ³ Velocity m/s	Minimum Flow Rate (m ³ /h)										Max. Flow Rate (m ³ /h)	
		0.38	0.7	1.2	2.0	3.6	6	11	19	34	(60)		
		20.3	15.0	11.8	10.0	8.2	6.9	5.7	4.7	3.9	3.2		50
Table C	200 (8")	2300	1690	1330	1130	923	778	636	530	437	362	5650	
	250 (10")	3590	2640	2080	1760	1450	1220	994	828	682	565	8830	
	300 (12")	5160	3810	3000	2530	2080	1750	1430	1200	982	813	12700	
	400 (16")	9180	6760	5330	4490	3690	3120	2550	2120	1750	1450	22600	
	500 (20")	14400	10600	8320	7020	5770	4870	3980	3320	2730	2260	35300	
	600 (24")	20700	15200	12000	10100	8310	7010	5730	4770	3930	3250	50800	
	800 (32")	36700	27100	21300	18000	14800	12500	10200	8480	6990	5780	90400	
	1000 (40")	57400	42300	33300	28100	23100	19500	15900	13300	10900	9030	141000	
	1500 (60")	129000	95100	74900	63200	51900	43800	35800	29800	24600	20400	318000	
2000 (80")	230000	169000	133000	113000	92300	77800	63600	53000	43700	36200	565000		
Table D	Type of Gases	Density kg/m ³	Gas Pressure (MPa (gauge)) at 20°C										(Ref.) Viscosity of Gas
	Acetylene	1.175	—	—	0	0.08	0.23	0.55	0.9	1.65	—	—	0.000943(mPa·s)
	Argon	1.785	—	—	—	0.02	0.12	0.26	0.55	1.05	2	—	0.0007
	Ammonia	0.771	—	0	0.07	0.21	0.42	0.75	1.45	—	—	—	0.00092
	Carbon Monoxide	1.250	—	—	0	0.07	0.21	0.42	0.85	1.55	—	—	0.00166
	Ethane	1.357	—	—	0	0.06	0.18	0.37	0.8	1.4	—	—	0.00085
	Ethylene	1.264	—	—	0	0.07	0.21	0.42	0.85	1.55	—	—	0.00097
	Air	1.293	—	—	0	0.07	0.2	0.4	0.85	1.5	—	—	0.0017
	Oxygen	1.429	—	—	0	0.05	0.1	0.35	0.75	1.35	—	—	0.00192
	Hydrogen	0.0899	0.35	0.73	1.33	—	—	—	—	—	—	—	0.00084
	Carbon Dioxide	1.977	—	—	—	0.01	0.1	0.23	0.5	0.95	1.7	—	0.00138
	Nitrogen	1.251	—	—	—	0.07	0.21	0.42	0.85	1.55	—	—	0.00166
	City Gas	0.802	—	0	0.06	0.17	0.38	0.7	1.4	—	—	—	0.001
	Natural Gas	0.828	—	0	0.06	0.16	0.37	0.68	1.35	—	—	—	0.00107
	Freon-12	5.533	—	—	—	—	0	0.02	0.12	0.27	0.56	1.1	0.00127
Propane	2.020	—	—	—	0.01	0.09	0.22	0.49	0.9	1.7	—	0.00075	
Butane	2.703	—	—	—	0	0.04	0.14	0.34	0.65	1.2	—	0.00069	
Methane	0.717	—	0	0.08	0.2	0.44	0.8	1.55	—	—	—	0.00103	

Example :

Find the minimum flow rate where fluid: air, temp.: 20°C, pressure: 0.5MPa (gauge), and actual bore size: 477.8mm. Minimum flow rates at 0.4MPa and 0.85MPa of air with respect to a bore of 500mm in Table D are 4870 m³/h and 3980 m³/h, respectively, from Table C. The minimum flow rate at 0.5MPa can therefore be determined by proportion and formula [A] as follows:

$$Q_{mm} = \left\{ 3980 + \frac{0.85-0.5}{0.85-0.4} \times (4870-3980) \right\} \left(\frac{477.8}{500} \right)^2$$

$$\doteq 4300 \text{ m}^3/\text{h}$$

It can also be determined by calculating the actual density. Actual density ρ of air at 20°C and 0.5MPa is

$$\rho = 1.293 \times \frac{273.15}{273.15+20} \times \frac{0.1013+0.5}{0.1013} = 7.04 \text{ kg/m}^3$$

From Table C, the minimum flow rate at a density of 6kg/m³ and bore of 500 mm is 4870 m³/h; at a density of 11kg/m³, it should be 3980 m³/h. The minimum flow rate at a density of 7.04kg/m³ therefore can be found by proportion and formula [A] as follows:

$$Q_{min} = \left\{ 3980 + \frac{11-7.04}{11-6} \times (4870-3980) \right\} \times \left(\frac{477.8}{500} \right)^2$$

$$\doteq 4300 \text{ m}^3/\text{h}$$

● Flow Range for Saturated Steam

Table E

Unit : t/h

N.B.S* Flow Rate Press. MPa(gauge)	200(8")		250(10")		300(12")		400(16")		500(20")		600(24")		800(32")		1000(40")		1500(60")		2000(80")		Temp. °C	Density kg/m ³
	Min.	Max.	Min.	Max.	Min.	Max.	Min.	Max.	Min.	Max.	Min.	Max.	Min.	Max.	Min.	Max.	Min.	Max.	Min.	Max.		
0.049	1.32	4.89	2.06	7.64	2.96	11.0	5.26	19.5	8.22	30.5	11.9	44.0	21.1	78.2	32.9	122	74.0	275	132	489	111.4	0.8653
0.098	1.50	6.37	2.35	9.94	3.38	14.3	6.00	25.4	9.38	39.7	13.5	57.3	24.0	101	37.5	159	87.4	358	150	636	120.1	1.126
0.196	1.97	9.26	3.07	14.4	4.42	20.8	7.86	37.0	12.3	57.8	17.7	83.3	31.5	148	49.2	231	111	521	197	926	133.3	1.638
0.294	2.35	12.1	3.67	18.9	5.29	27.2	9.39	48.4	14.7	75.6	21.2	108	37.6	193	58.7	302	132	680	235	1210	143.2	2.140
0.392	2.70	14.9	4.22	23.2	6.07	33.5	10.8	59.6	16.9	93.1	24.3	134	43.2	238	67.5	372	152	838	270	1490	151.4	2.635
0.490	3.03	17.6	4.73	27.6	6.81	39.7	12.1	70.7	18.9	110	27.2	159	48.4	282	75.6	442	170	994	303	1760	158.3	3.127
0.588	3.33	20.4	5.21	31.9	7.50	45.9	13.4	81.7	20.9	127	30.0	183	53.3	327	83.3	511	188	1140	333	2040	164.4	3.615
0.686	3.62	23.1	5.66	36.2	8.15	52.1	14.5	92.7	22.7	144	32.6	208	58.0	370	90.6	579	204	1300	362	2310	169.8	4.099
0.785	3.90	25.9	6.10	40.4	8.78	58.2	15.6	103	24.4	161	35.1	233	62.4	414	97.5	647	220	1450	390	2590	174.7	4.581
0.883	4.17	28.6	6.52	44.7	9.38	64.4	16.7	114	26.1	178	37.6	257	66.7	458	105	715	235	1610	417	2860	179.2	5.064
0.981	4.44	31.4	6.93	49.0	9.98	70.6	17.8	125	27.7	196	39.9	282	71.0	502	111	785	250	1760	444	3140	183.3	5.553
1.08	4.69	34.1	7.32	53.3	10.6	76.7	18.8	136	29.3	213	42.2	307	75.0	545	118	852	264	1910	469	3410	187.2	6.033
1.18	4.93	36.8	7.70	57.5	11.1	82.8	19.8	147	30.8	230	44.4	331	78.9	588	124	920	278	2070	493	3680	190.8	6.509

*N.B.S.=Nominal Size

● Flow Range for Superheated Steam

The flow range for superheated steam is determined by first finding the correction factors “a” and “b” for the minimum flow rate and maximum flow rates from the table below and

then multiplying the applicable connection diameter and pressure readings in the flow range table of saturated steam by those correction factors.

Table F:

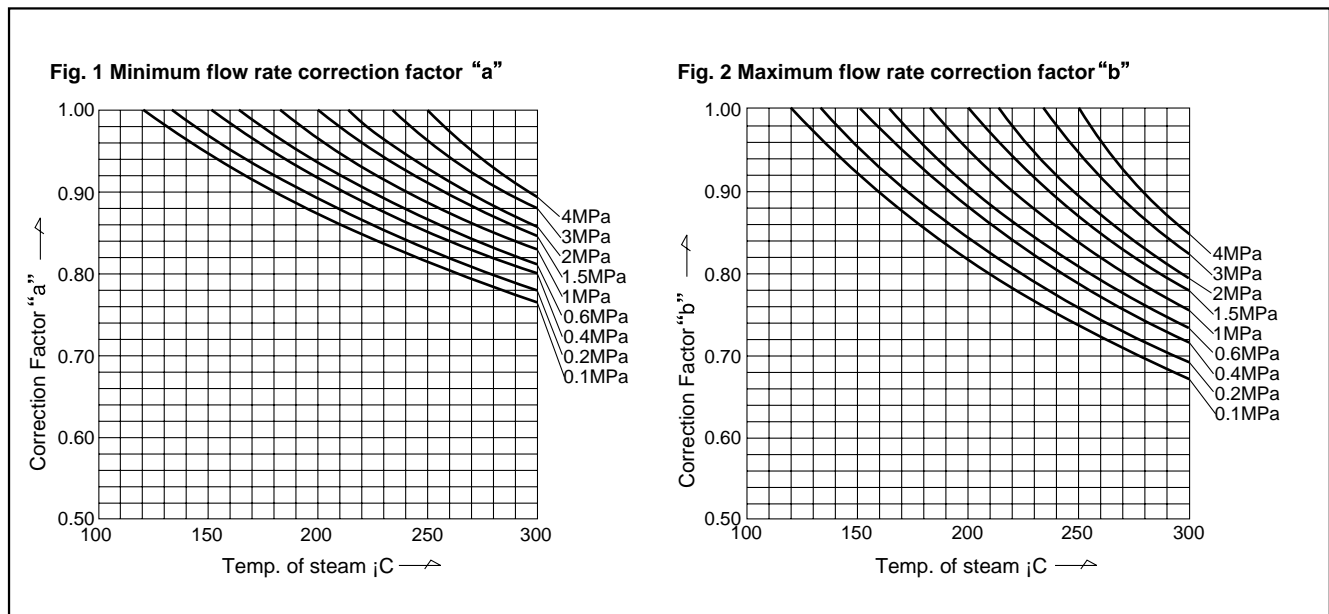

Example:

Measurement of super heated steam of pressure 0.1MPa (gauge) and temperature 160°C in actual bore size 477.8mm.

From table E, minimum flow rate and maximum flow rate for 0.1MPa steam with nominal bore size 500mm are determined as 9.38t/h and 39.7t/h.

Correction factor “a” is determined as 0.93 from Fig. 1 and Correction factor “b” is determined as 0.9 from Fig. 2 and consulting from Table E and formula [A].

Min. flow rate

$$Q_{min} = 9.38 \times 0.93 \times \left(\frac{477.8}{500}\right)^2 \doteq 8 \text{ t/h}$$

Max. flow rate

$$Q_{max} = 39.7 \times 0.9 \times \left(\frac{477.8}{500}\right)^2 \doteq 32 \text{ t/h}$$

■ PRESSURE LOSS

● Liquid Service

$$\Delta P = \frac{C \times \rho}{10^5}$$

ΔP = Pressure loss (kPa)

ρ = Density (kg/m³)

C = Pressure loss coefficient

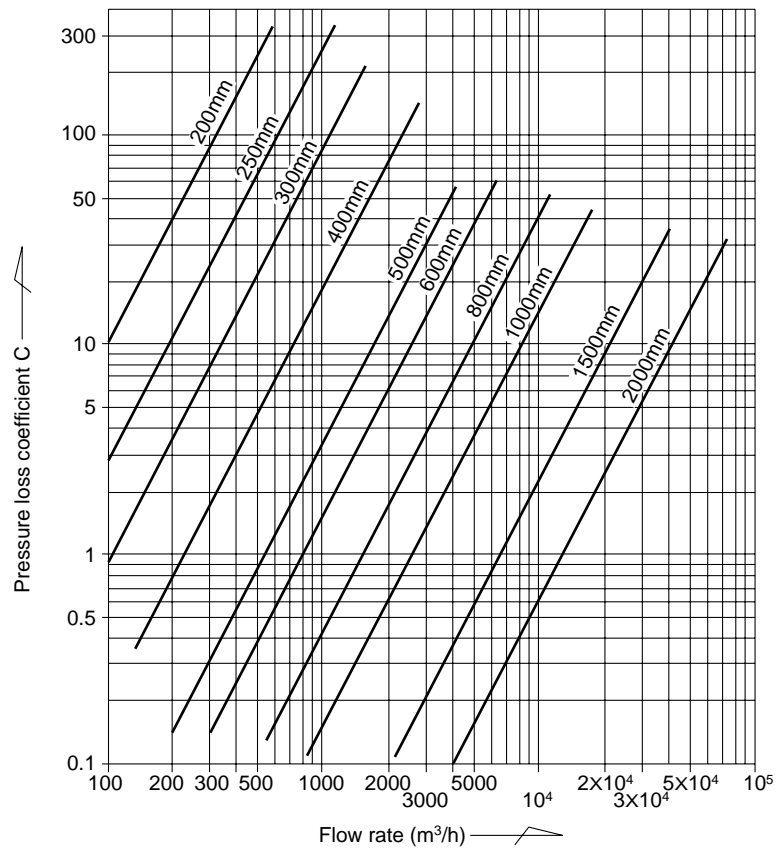

● Gas, Steam Service

$$\Delta P = \frac{C \times \rho}{100}$$

ΔP = Pressure loss (kPa)

ρ = Density (kg/m³)

C = Pressure loss coefficient

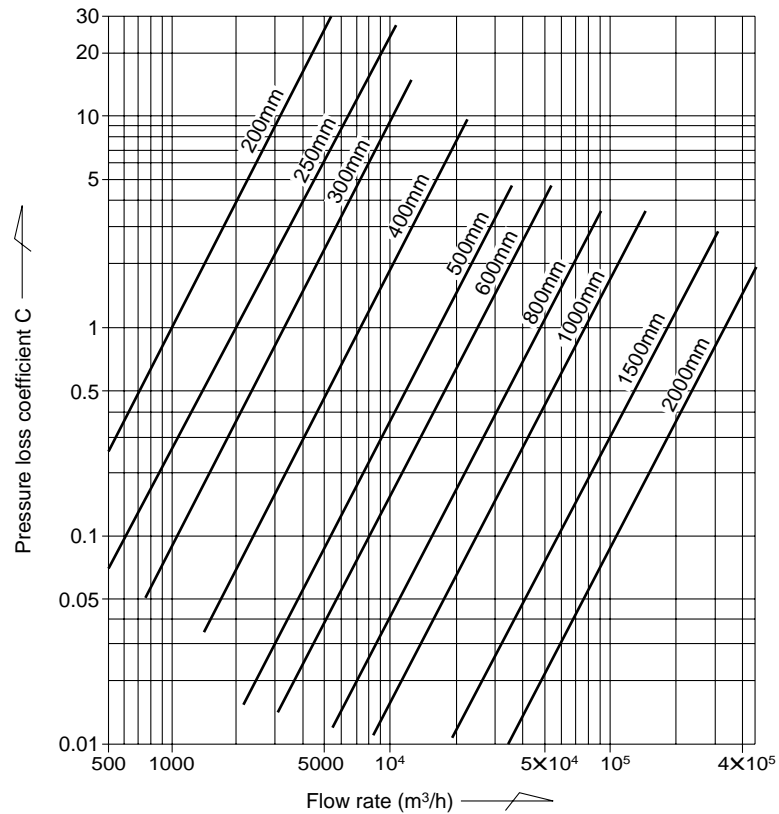

■ OUTLINE DIMENSIONS

● Fixed Type

Converter: Integral type
 Nominal Size to be applied: 200 to 1300mm
 In case of bore size more than 1300 mm,
 consult factory.

Ln: Height of mounting neck (std. 100 mm)
 y : Length of insertion
 Nominal size < 500 mm; 0.5 X D
 Nominal size ≥ 500 mm; 0.2 X D
 D = Inner dia. of piping

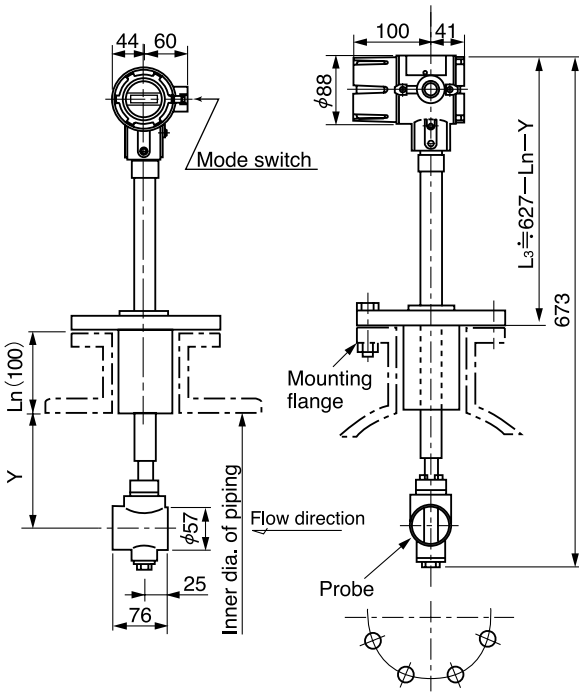

● Fixed Type

Converter: Separate type
 Nominal Size to be applied: 200 to 1300mm
 In case of bore size more than 1300 mm,
 consult factory.

Ln: Height of mounting neck (std. 100 mm)
 y : Length of insertion
 Nominal size < 500 mm; 0.5 X D
 Nominal size ≤ 500 mm; 0.2 X D
 = Inner dia. of piping

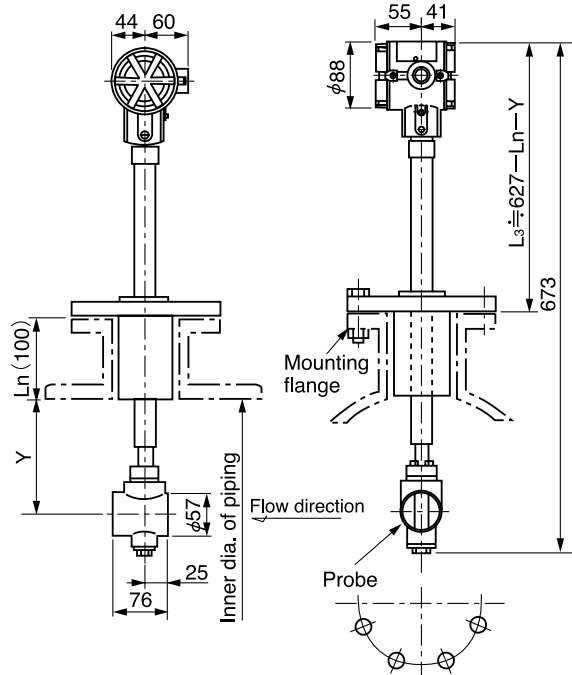

● Display Mode

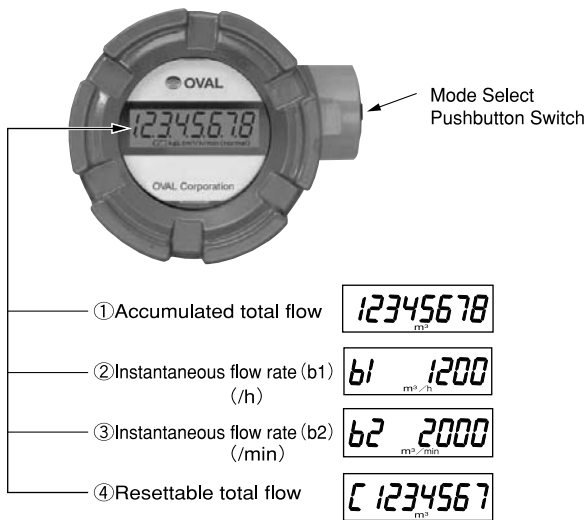

To reset the counter, hold the display mode select switch depressed for 5 seconds.

● Separate Type Converter

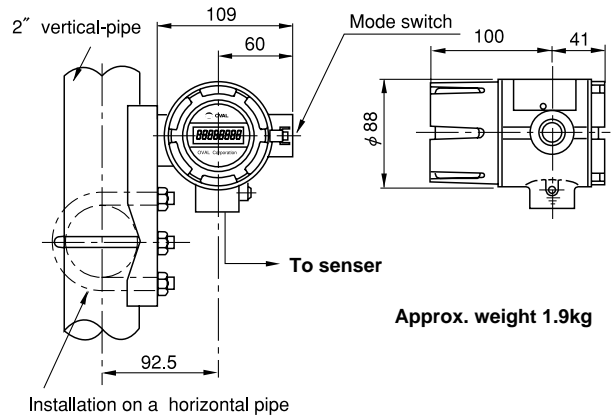

Approx. weight 1.9kg

Unit : mm

● Hot-tap type

Nominal size to be applied: 400 to 2000mm

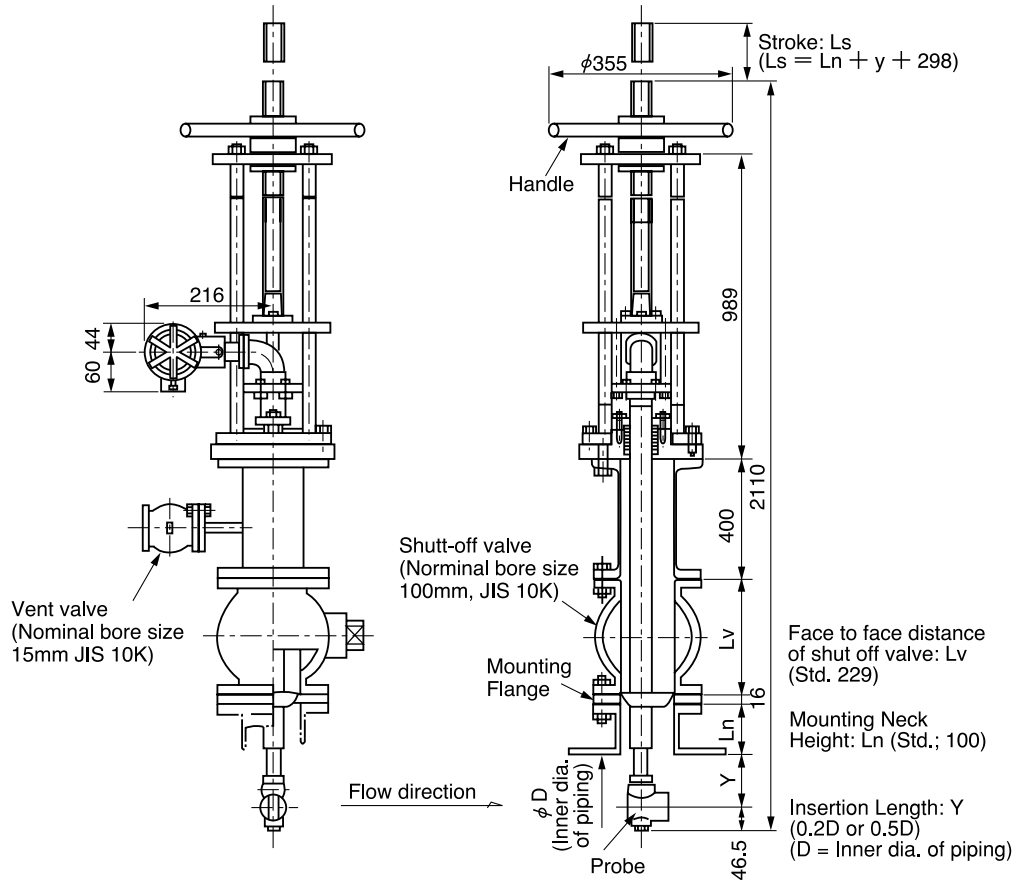

● Mounting Direction of Transducer

Standard: Slant to the left viewing from flow inlet side.
 Mode switch should face downward to prevent water invasion.

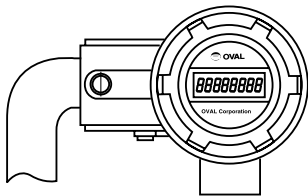

■ INSTALLATION CONDITIONS

1. TYPICAL PIPING INSTRUCTIONS

It is generally required that the flow pattern of a fluid flowing in and out of an inferential type flow meter be as uniform as possible for accurate metering performance. All account of this, proper flow straightening measures

have to be applied for piping installation of EX DELTA. The standard piping instructions are shown in the following table.

Use an OVAL flow straightener or install straight pipes conforming to established standards (ISO-5167).

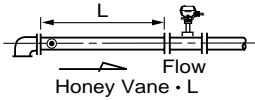
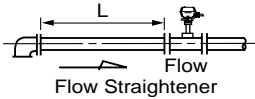
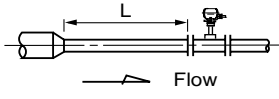
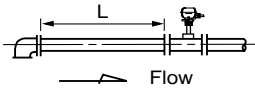
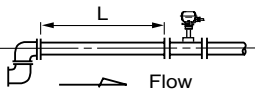
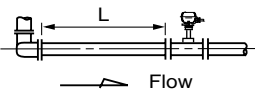
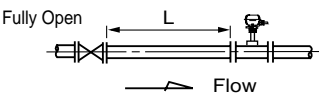
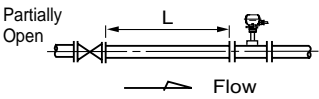
No.	Piping Arrangement	Straight Pipe Length(L)	Remarks	
1	 OVAL's flow Straightener Honey Vane · L	8D	For Honey Vanes L, consult the factory	
		 Flow Straightener	12D	Refer to GS/GCF001.(Applicable to meter size up to 24")
2	 Reducer	15D Min.	A concentric reducer is upstream of the meter.	
3	 Elbow	23D Min.	An elbow is upstream of the meter.	
			25D Min.	Two elbows are upstream of the meter.
			40D Min.	Two elbows are vertically upstream of the meter.
4	 Fully Open Fully open gate valve	15D Min.	A full-open gate valve is upstream of the meter.	
5	 Partially Open Partially open gate valve	50D Min.	A partially open gate valve, sharp orifice or something that markedly disturbs the flow pattern is upstream of the meter.	

- Notes 1: "D" denotes pipeline diameter, not probe bore.
 2: A short pipe section, 5D or longer is provided downstream of the meter.
 3: For pressure detection, provide the probe downstream of the flowmeter (see figure below). To avoid disturbances in the flow, temperature detection should be made downstream of the flowmeter and, at the same time, upstream of the control valve.

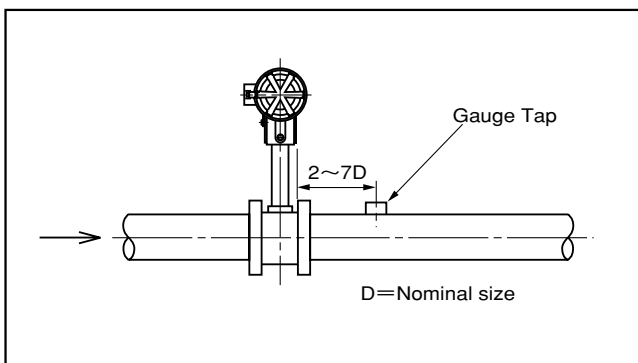

● **Mounting Neck:**

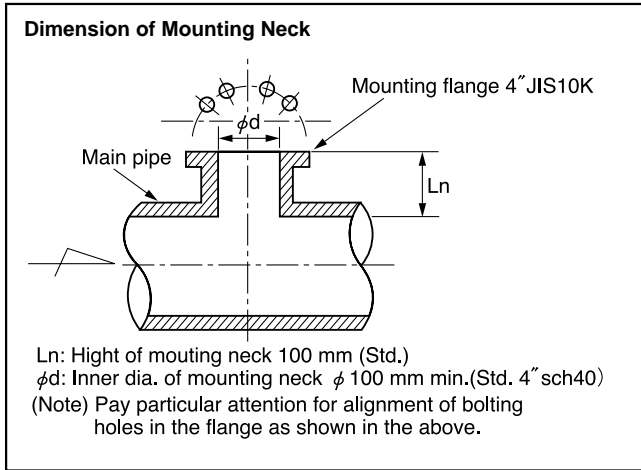

- Fluid to be measured shall be full in a pipe. Air vent valve is needed when non-filling flow is possible.

- Construction of working stage is recommended for securing safety maintenance operation. Lifting device is also required, in case of Hot-tapping type.

● **Pulsation**

Installing this flowmeter in a line where a roots-blower, compressor, etc. that produce pulsating pressures are used as blowers could subject the meter to the effects of pulsation. If such is the case, consult factory. The value of allowable fluctuating pressure shall be given according to the following equation.

$$N < 0.72 \rho V^2 \text{ (Pa)}$$

where N: Fluctuating press.(Pa)

ρ : Density of liquid to be measured (kg/m³)

V: Min. velocity (m/s)

● **Thermal Insulation**

If it is desired to thermally insulate the pipe line, simple laggings (without mortar finish) are suggested to facilitate servicing. This arrangement will permit taking off flow-meter connecting bolts without destroying the lagging.

■ PRODUCT CODE EXPLANATION

Item	Code No.															Description		
	1	2	3	4	5	6	7	-	8	9	10	11	-	12	13		14	15
Model	V	X																EX DELTA
Body Style	S																	Fixed Type
	H																	Hot-tap Type
Application	1																	Standard (Under 180°C)
	3																	High Temp. Service (Over 180°C)
Probe Size			0	5	0	-												50mm (2")
Major Parts Material	D																	Stainless Steel SUS304
	Z																	Special
Flange Rating	1																	JIS 10K
	5																	ANSI 150 See Note 1
	7																	JPI 150
	9																	Other than above
Sensor Configuration	1																	Standard
Fluids to be Metered	G	-																Gas, Steam
	L	-																Liquid
Converter Configuration	1																	Integral type
	2																	Separate type
Explosion-proof Configuration	0																	None (non-explosionproof)
	3																	Intrinsically safety
Display																1	w/Totalizer & Digital indicator See Note 2	
Output signal																	0	Non Output (Battery powered type)

Note 1. Flange serration for ANSI standard: ASME/ANSI B 16.5—1996.

Note 2. Display item is selected by Internal Switch from one of the following items:

- (1) Totalizing counter
- (2) Instantaneous flow rate (/h)
- (3) Instantaneous flow rate (/min)
- (4) Reset counter

■ When making inquiries, please specify the following:

Fill in the blanks or check with ✓ mark.

ITEM	DESCRIPTION
1.Fluid to be Metered	
2.Flow Range	Max._____ Normal_____ Min._____ <input type="checkbox"/> m ³ /h[normal] <input type="checkbox"/> m ³ /h[actual] <input type="checkbox"/> kg/h
3.Temp. Range	Max._____ Normal_____ Min._____ °C
4.Press. Range	Max._____ Normal_____ Min._____ <input type="checkbox"/> MPa [gauge]
5.Density or Sp. Gr.	Density_____ <input type="checkbox"/> kg/m ³ [normal] , <input type="checkbox"/> kg/m ³ [actual] Sp. Gr.
6.Viscosity	_____ <input type="checkbox"/> mm ² s, <input type="checkbox"/> mm ² /S at _____ °C
7.Actual inner Dia. of mainline pipe	Nominal size_____mm Actual inner Dia_____mm
8.Type of mounting	<input type="checkbox"/> Fixed Type <input type="checkbox"/> Hot-tap Type
9.Flow straightening device:	<input type="checkbox"/> Req'd (straightener and down stream pipe) <input type="checkbox"/> Not req'd (Please prepare the straightening pipe of specific length, bore and sch. no.)
10.Compensation	<input type="checkbox"/> Requested <input type="checkbox"/> Not requested
11.Compensation Range	Temp._____ to _____°C , Pressure_____ to _____ <input type="checkbox"/> MPa [gauge]
12.Compensation Ref.	Ref. temp._____°C Press. ref._____ <input type="checkbox"/> MPa [gauge]
13.Compression coefficient: (in case of gas measurement)	Z (service conditions) = _____ Zo (standard conditions) = _____
14.Converter	Type : <input type="checkbox"/> Integral configuration <input type="checkbox"/> Separate configuration Explosionproof configuration : <input type="checkbox"/> Non-explosionproof <input type="checkbox"/> Intrinsically safety
15.Explosion-proof construction	<input type="checkbox"/> Not requested <input type="checkbox"/> Requested
16.Miscellaneous	

The specification as of July, 2008 is stated in this GS Sheet. Specifications and design are subject to change without notice.



Sales Representative:
icenta CONTROLS Ltd
North Station Yard, Warminster Road, Wilton, Salisbury, SP2 0AT
Tel: 0845 895 1020 Fax: 0845 895 1021
Email: sales@icenta.co.uk
www.icenta.co.uk

GS.No.GBD604E

初版	改訂	印刷
99.3	08.7	