



High performance and wide viscosity range
EX TURBINE
 MODEL : TX Series (Nom. sizes 15mm to 400mm)

GENERAL SPECIFICATION
GS.No.GBT103E-12

■ GENERAL

EX TURBINE is an industrial turbine meter for consistent and accurate liquid flow measurement. It offers a wide viscosity range and accepts flows even in low Reynolds number regions. The turbine meter is mainly applicable to flow measurement of petroleum products (white products), LPG, and water.

■ FEATURES

1. High viscosity version specially has a high metering accuracy even in low Reynolds number regions.
2. Linearity within $\pm 0.15\%$, repeatability within $\pm 0.02\%$ is available for transactions of applicable liquid.
3. Direct and remotely transmitted registration of total flow and instantaneous flowrate are provided.
4. 13 meter sizes in nominal sizes from 15mm thru 400mm.



■ GENERAL SPECIFICATIONS

● Meter Body

Item		Description												
Model		Standard or Low viscosity					Standard or high viscosity							
Nominal size (mm)		15	20	25	40	50	80	100	150	200	250	300	350	400
Connection		Flange Connection (RF : St'd)												
Flange rating		JIS 10, 16, 20, 30K ANSI/JPI 150, 300												
Applicable fluid		Liquid (petroleum, LPG, water, etc)												
Flow rate		See flow range table (page 3).												
Operating Temp. Range	Standard	-30 to +120°C (Explosionproof : -20 to +120°C)												
	High Temp.	-30 to +350°C (Explosionproof : -20 to +290°C)												
	Low Temp.	-196 to +120°C (※2)					-100 to +120°C (※3)							
Max. Operating Pressure		Depends on flange rating (see table below).												
Linearity (※1)		$\pm 0.15\%$ or $\pm 0.35\%$ of RD												
Repeatability		0.05% (※4)												
Materials	Body	SCS14+SUS304 (nominal size 15mm only), SUS304												
	Support	SUS304												
	Rotor	SUS630					SUS631 (※5)			SUS316+NAS64 (SUS631) (※5)				
	Bearings	Super hard alloy (GTi30)												
	Shaft	Super hard alloy (GTi30)						Super hard alloy (HTi10)						
Installation		Horizontal												

※1 : In case of analog output, $\pm 0.1\%$ of FS is added. In order to secure specified accuracy, "Piping instruction" (page10) should carefully be observed.

※2, ※3 : Low temperature model is not of explosionproof.

※4 : $\pm 0.02\%$ with a flow straightener or Honey Vane L (perforated plate flow straightener).

※5 : The materials may differ depending on the specification.

● Flange Rating and Max. Operating Pressure (MPa)

Flange Rule		JIS 10K	JIS 16K	JIS 20K	JIS 30K	ANSI/JPI 150	ANSI/JPI 300
Operating Temp.	Below 120°C	1.18	1.96	2.45	4.51	1.51	3.90
	Above 120°C, less than 300°C	0.98	1.77	2.26	4.22	1.02	2.90

OVAL Corporation

<http://www.oval.co.jp>

Head Office (Tokyo): Phone. 81-3-3360-5121. Fax. 81-3-3365-8605
 Beijing Office: Phone. 86-10-5867-4711. Fax. 86-10-5867-4713
 Overseas Branch Offices: Seoul, Singapore and Taipei

● Converter Specifications

Item	Description	
Model	PA14	PA14S (Totalizer)
Indicator (Option)	Display: Total counter, with 8 digits LCD Unit: Same as scaled pulse • Counter reset by internal switch	
Output signal Current signal, 2-conductor (common with power lines)	One of the following pulse types is selected: 1: Unscaled pulse type (single) Pulse width : 200µs (※1) 2: Unscaled pulse type (double) Pulse width : 100µs Pulse levels [0]=4mADC [1]=20mADC 3: Scaled pulse type Pulse width : 50ms 4: Pulse type to be connected with exclusive receiver (EL0134) Pulse width : 200µs 5: Analog type, 4 to 20mADC at 0 to FS Time constant : 2.5S (FS≥20Hz) or 10S (FS<20Hz)	Only one of type 1, 2, 3, 4 is available as output.
Cable (※2)	Converter to receiving instrument: 1.25mm ² min., 2-conductor shielded cable Finished cable outside diameter: Nonexplosion-proof ø13.5mm max. Flameproof ø8.5 to ø11mm	
Transmission length	Converter to receiving instrument: 1km. max.	
Power supply	12 to 45V DC (See load resistance range curve.)	
Electrical connection	G1/2 internal thread In the flameproof construction, the external cable lead-in is of pressure-tight packing type (dedicated lead-in fitting furnished). (For T2/high temperature service, a pressure-tight conduit screw-in type is acceptable.)	
construction	TIIS Flameproof construction Exd IIB+H ₂ T2 (High Temp.), Exd IIB+H ₂ T4 (High Temp. /Standard)	
Waterproof construction	IP66	
Ambient Temperature (Refer to the Fig. below.)	-40 to +80°C (Explosionproof : -20 to +60°C)	-20 to +60°C
Ambient humidity	5 to 100%RH without dew condensation	
Material	Aluminum alloy	
Finish	Finished in baked melamine Munsell 2.5G8/2 (Cover: Munsell 2.5BG5/6)	

※1 : Pulse type provides both single and double. Single pulse is standard. Double pulse type reduces test time when meter calibration with "Small Volume Compact Prover" is specified.

※2 : If ambient temperature exceeds 55°C, use cables heat resistant to 70°C or higher.

NOTE: Even in applications where ambient temperature is held below 55°C, use cables specified for individual products to withstand 60°C or higher.

● Acceptable Load Resistance Range

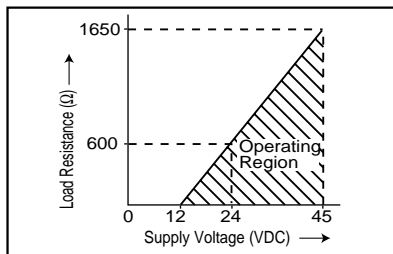

● Ambient Temperature Range

If fluid temperature exceeds 125°C, derate according to the diagram below.

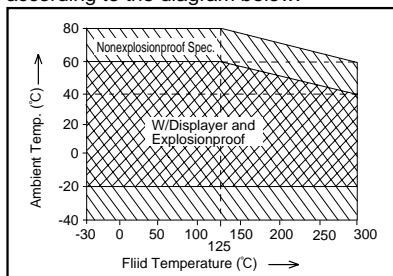

● Output Signal Units and Display Units

Nominal size mm (inch)	Max. Flow rate m ³ /h (※3)	Meter factor L/P		Pulse output frequency (Hz)(※4)		Units of scaled pulse output and total counter for PA14 and PA14S		
		Single	Double(※2)	Single	Double	Min.	St'd	Max.
15 (1/2)	4.2	0.00233	0.001165	119Q	238Q	1L/P	10L/P	100L/P
20 (3/4)	8.4	0.00476	0.002380	58.4Q	117Q	1L/P	10L/P	100L/P
25 (1)	13	0.00769	0.003845	36.1Q	72.2Q	1L/P	10L/P	100L/P
40 (1 1/2)	33	0.01818	0.009090	15.3Q	30.6Q	1L/P	10L/P	1m ³ /P
50 (2)	54	0.03030	0.01515	9.17Q	18.3Q	10L/P	100L/P	1m ³ /P
80 (3)	160	0.07936	0.03968	3.50Q	7.00Q	10L/P	100L/P	1m ³ /P
100 (4)	300	0.1887	0.09435	1.47Q	2.94Q	10L/P	100L/P	10m ³ /P
150 (6)	650	0.1428	0.07140	1.95Q	3.89Q	100L/P	1m ³ /P	10m ³ /P
200 (8)	1400	0.3030	0.1515	0.917Q	1.83Q	100L/P	1m ³ /P	10m ³ /P
250 (10)	2200	0.4831	0.2416	0.575Q	1.15Q	100L/P	1m ³ /P	10m ³ /P
300 (12)	3000	0.6250	0.3125	0.444Q	0.889Q	100L/P	1m ³ /P	10m ³ /P
350 (14)	3500	1.000	0.5000	0.278Q	0.556Q	100L/P	1m ³ /P	100m ³ /P
400 (16)	4500	1.587	0.7935	0.175Q	0.350Q	1m ³ /P	10m ³ /P	100m ³ /P

※3 : Intermittent flow.

※4 : Output frequency in each flowrate is calculated by substituting flowrate Q (m³/h).

※ : Output signal "5" in the last digit of product code represents unscaled double pulse output frequency 2 times higher than unscaled single pulse frequency.

■ FLOW RANGES

Flow range of the meter varies with temperature and viscosity referred to in determining respective flow range. of liquid to be metered. The following tables 1 to 3 should be

● **Table 1:** (Standard type ... Nom. sizes 15 to 50mm for viscosity above 0.3mPa·s or nom. sizes 80 to 400mm for kinematic viscosity below 2mm²/s, and nom. sizes 80 to 400mm for high temperature service)

Unit in m³/h

Temp. range	Nominal size mm	Min. Flowrate				Max. Flowrate	
		Linearity ± 0.35%		Linearity ± 0.15%		Intermittent	Continuous
		A	B	A	B		
-30 to +120°C	15	0.63	0.6 x ν	2	1.7 x ν	4.2	2.7
	20	0.90	0.9 x ν	3.5	2.3 x ν	8.4	5.5
	25	1.5	1.5 x ν	4.5	2.8 x ν	13	8.5
	40	2.7	2.7 x ν	9	4.5 x ν	33	20
	50	4.3	4.3 x ν	15	5.6 x ν	54	36
-100 to +350°C	80	10	13.6 x ν	20	22.6 x ν	160	125
	100	20	17.0 x ν	35	28.3 x ν	300	240
	150	50	25.5 x ν	70	42.4 x ν	650	500
	200	70	33.9 x ν	110	56.5 x ν	1400	1100
	250	100	42.4 x ν	200	70.7 x ν	2200	1600
	300	180	50.9 x ν	250	84.8 x ν	3000	2400
	350	280	59.4 x ν	350	98.9 x ν	3500	2800
400	350	67.8 x ν	410	113 x ν	4500	3600	

● **Table 2: High viscosity version**

Applicable nominal sizes 80 to 400mm above 2 to 3mm²/s in viscosityUnit in m³/h

Temp. range	Nominal size mm	Min. Flowrate				Max. Flowrate	
		Linearity ± 0.35%		Linearity ± 0.15%		Intermittent	Continuous
		A	B	A	B		
-100 to +350°C	80	15	4.52 x ν	30	6.78 x ν	160	125
	100	35	5.65 x ν	50	8.48 x ν	300	240
	150	50	8.48 x ν	70	12.8 x ν	650	500
	200	90	11.3 x ν	140	17.0 x ν	1400	1100
	250	150	14.2 x ν	250	21.2 x ν	2200	1600
	300	200	17.0 x ν	300	25.5 x ν	3000	2400
	350	280	19.8 x ν	400	29.7 x ν	3500	2800
	400	350	22.6 x ν	450	33.9 x ν	4500	3600

● **Table 3: Low temp. version & High temp. version**

Nominal sizes: 15 to 50mm

Unit in m³/h

Temp. range	Nominal size mm	Min. Flowrate				Max. Flowrate	
		Linearity ± 0.35%		Linearity ± 0.15%		Intermittent	Continuous
		A	B	A	B		
-196°C to -30°C or 120°C to 350°C	15	1	0.6 x ν	2	1.7 x ν	4.2	2.7
	20	1.4	0.9 x ν	3.5	2.3 x ν	8.4	5.5
	25	2	1.5 x ν	4.5	2.8 x ν	13	8.5
	40	3.5	2.7 x ν	9	4.5 x ν	33	20
	50	4.3	4.3 x ν	15	5.6 x ν	54	36

● **Table 4:** (Low viscosity type ... In an application where viscosity is below 0.3mPa·s or accuracy is ±0.15% in standard type, when a greater low end flowrate is required, applicable nominal sizes are 15 to 50mm.)

Unit in m³/h

Temp. range	Nom. size mm	Min. Flowrate		Max. Flowrate	
		Linearity ±0.2%		Intermittent	Continuous
		A	B		
-30 to +120°C	15	1.5	—	4.2	2.7
	20	2.5	—	8.4	5.5
	25	3.0	—	13	8.5
	40	6.0	—	33	20
	50	10	—	54	36

※1 : “ ν ” represents kinematic viscosity (mm²/s) of liquid to be metered.

※2 : Larger value in either column A or B is specified.

※3 : Not available when kinematic viscosity is high and the value in B of min. flowrate exceeds max. continuous flowrate.

※4 : For nominal sizes 80 to 400mm for viscosities 2 to 3mm²/s, consult the factory.

※5 : “Intermittent” flow indicates operation within 8 hrs/day.

※6 : Low end flowrate in the ±0.35% accuracy, low viscosity model is the same as the standard type.

※7 : Accuracy specifications ±0.35% and ±0.15% are independent of each other. Hence, a single flowmeter cannot handle flow ranges of ±0.35% and ±0.15%.

■ PERFORMANCE CHARACTERISTICS

● PRESSURE LOSSES

Nominal sizes: 15 to 50mm

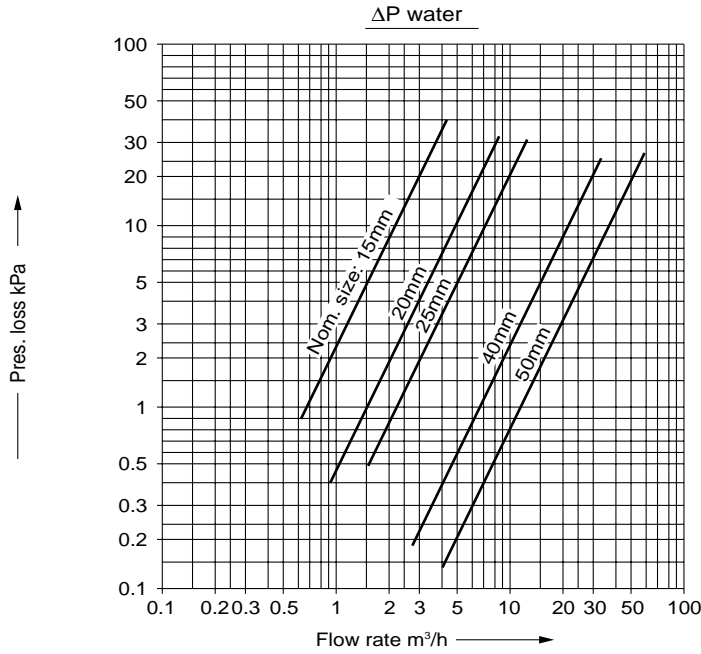

- Water: (Specific gravity 1g/mL
Viscosity 1mm²/s
- To obtain actual ΔP for liquids other than water, the following equation is used:

$$\Delta P = \Delta P_0 \times \rho \times \nu^{0.25} \text{ (kPa)}$$

where:

- ΔP : Liquid pressure loss to be metered
- ΔP_0 : The value that read from the left graph
- ρ : Liquid density to be metered; g/mL
- ν : Kinematic viscosity; mm²/s

Nominal sizes: 80 to 400mm

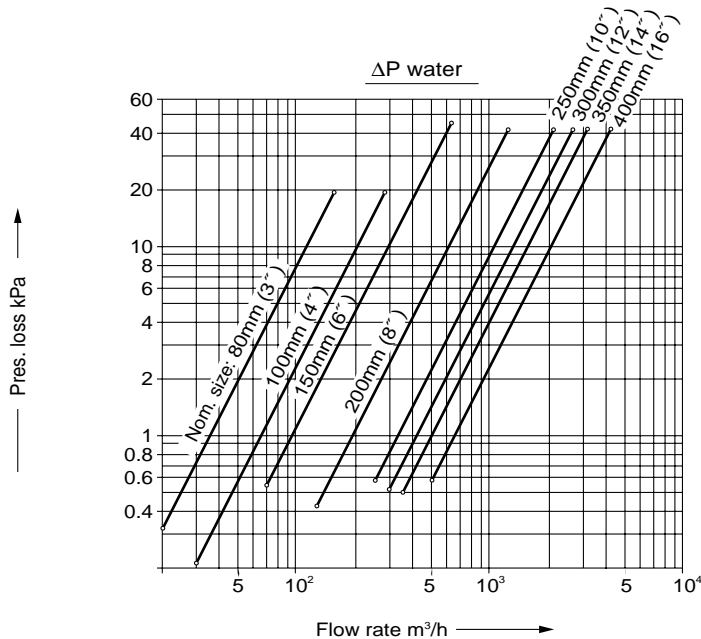

- Water: (Specific gravity 1g/mL
Viscosity 1mm²/s
- To obtain actual ΔP for liquids other than water, the following equation is used:

$$\Delta P = \Delta P_0 \times \rho \times \nu^{0.25} \text{ (kPa)}$$

where:

- ΔP : Liquid pressure loss to be metered
- ΔP_0 : The value that read from the left graph
- ρ : Liquid density to be metered; g/mL
- ν : Kinematic viscosity; mm²/s

● PERFORMANCE CHARACTERISTICS

Meter Error (Nominal size: 25mm (1))

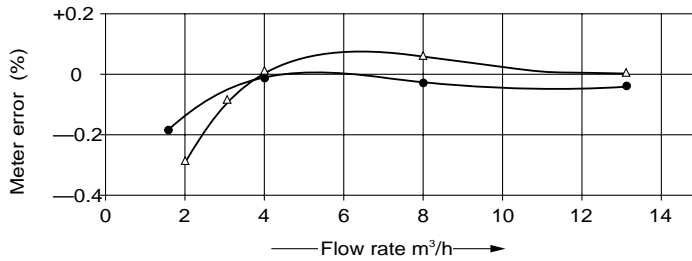

Meter factor: 7.352mL/P
 Length of Straightening pipe: 50 x D
 ● : Gasoline
 △ : Kerosene
 D = Nominal size

Meter Error Reynolds Numbers

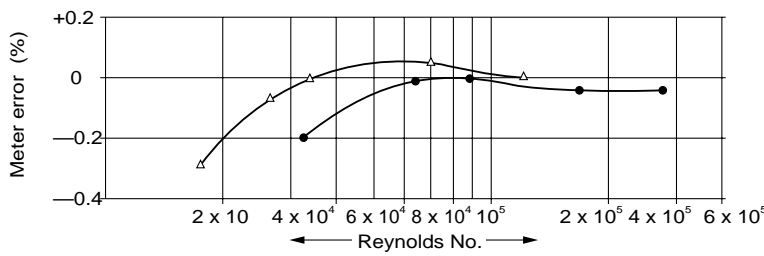

Meter factor: 7.352mL/P
 Length of Straightening pipe: 50 x D
 ● : Gasoline
 △ : Kerosene
 D = Nominal size

Standard Type (Nominal size: 150mm)

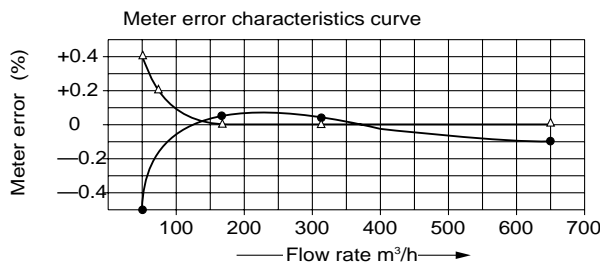

△ Kerosene (1.5mm²/s)
 ● Gasoline (0.57mm²/s)
 Nominal size: 150mm
 Length of flow straightening pipe: Straightening pipe 8D + Flow straightener

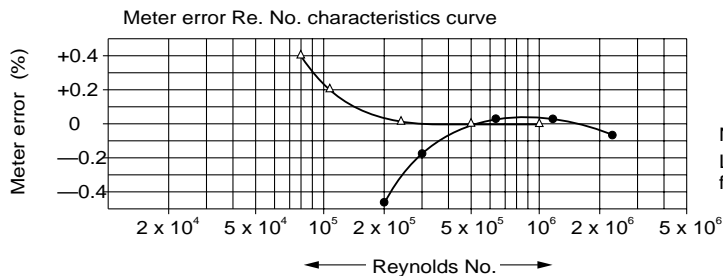

△ Kerosene (1.5mm²/s)
 ● Gasoline (0.57mm²/s)
 Nominal size: 150mm
 Length of flow straightening pipe: Straightening pipe 8D + Flow straightener

High Viscosity Type (Nominal size: 150mm)

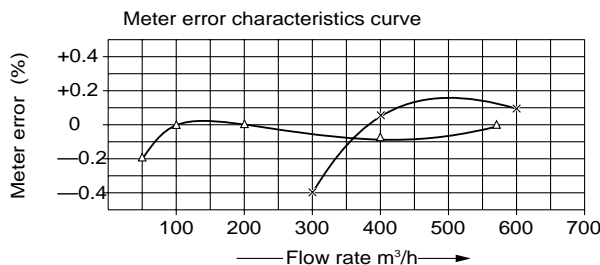

△ Kerosene (1.5mm²/s)
 × Fuel Oil (48.6mm²/s)
 ● Gasoline (0.57mm²/s)
 Nominal size: 150mm
 Length of flow straightening pipe: Straightening pipe 8D + Flow straightener

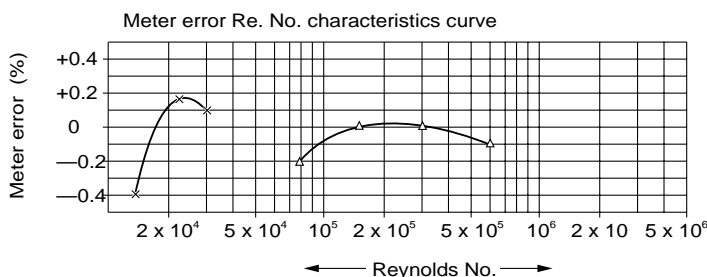

△ Kerosene (1.5mm²/s)
 × Fuel Oil (48.6mm²/s)
 ● Gasoline (0.57mm²/s)
 Nominal size: 150mm
 Length of flow straightening pipe: Straightening pipe 8D + Flow straightener

HOOK-UP WITH RECEIVING INSTRUMENTS

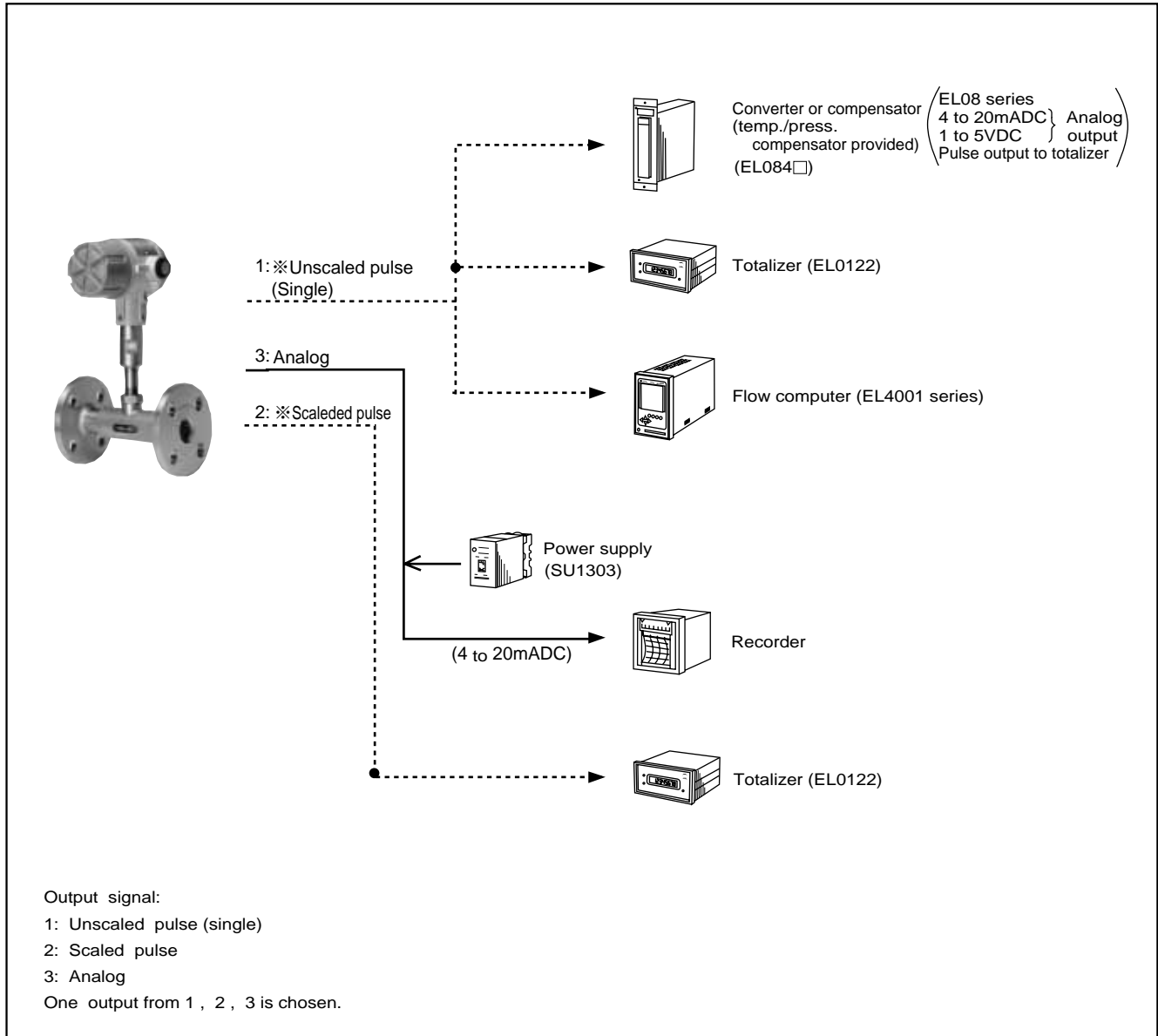

- NOTES: 1. For arrangement with any electrical instrument, indicator, etc. other than those supplied by OVAL, a 24VDC power supply is required. Use OVAL Model SU1302 power supply unit.
 2. Shown above are typical examples. Depending on individual applications and specifications, hookup with many other electrical instruments is possible.
 3. As to individual receiving instruments, see respective general specification sheets.

*** Current Pulse Output**

Unscaled and scaled pulse output levels are [1]: 20mADC and [0]: 4mADC.

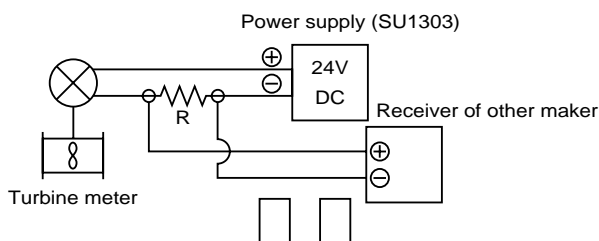
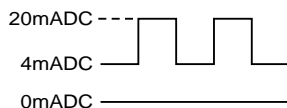

If you plan to use any instrument designed to accept a voltage pulse signal, couple a resistor in series as shown to furnish a voltage pulse.

Resistance (R)	[1]	[0]
250Ω	5VDC	1VDC
100Ω	2VDC	0.4VDC

The upper limit 600Ω on a 24VDC power supply. (Refer to the page 2.)

■ PRODUCT CODE EXPLANATION

Item	Code No.												Description		
	①	②	③	④	⑤	⑥	—	⑦	⑧	⑨	—	⑩		⑪	⑫
Model	T	X													EX Turbine
Type		1													Standard
		2													Low viscosity version (Max.0.3mPa·s) Nominal size 15 to 50mm
		5													High viscosity version (Min.2 to 3mm ² /s) Nominal size Min. 80mm
		9													Other than above
Nominal size	0	1	5	—											15mm (1/2")
	0	2	0	—											20mm (3/4")
	0	2	5	—											25mm (1")
	0	4	0	—											40mm (1 1/2")
	0	5	0	—											50mm (2")
	0	8	0	—											80mm (3")
	1	0	0	—											100mm (4")
	1	5	0	—											150mm (6")
	2	0	0	—											200mm (8")
	2	5	0	—											250mm (10")
	3	0	0	—											300mm (12")
	3	5	0	—											350mm (14")
4	0	0	—											400mm (16")	
Material							D								SUS304 (※1)
							Z								Other than above
Flange rating								1							JIS 10K RF
								2							JIS 16K RF
								3							JIS 20K RF
								4							JIS 30K RF
								5							ANSI 150 RF
								6							ANSI 300 RF
								7							JPI 150 RF
								8							JPI 300 RF
								9							Other than above
Operating temp. range								1	—						Standard (−30 to +120°C)
								2	—						High temp. Version (−30 to +350°C)
								3	—						Low temp. Version (−196 to −30°C) Nom. size: 15 to 50mm
								9	—						Other than above
Converter								1							PA14 (No display)
								4							PA14S (w/Totalizer) (※2)
								9							Other than above
Explosionproof construction								1							Non-Explosionproof
								5							Flameproof (TIIS)
								7							Flameproof (NEPSI)
Output signal								1							Unscaled pulse (Single)
								2							Scaled pulse
								3							Analog
								5							Unscaled pulse (Double)
								8							Unscaled scaled pulse (Combined with exclusive register)
								9							Other than above

※1 : Meter body for nominal size 15mm is a combination of SCS14A and SUS304.

※2 : Available only for both unscaled pulse (single, double) and scaled pulse.

■ **OUTLINE DIMENSIONS** [Unit in mm]

※ : Figures in brackets show the dimensions with built-in display

● **Standard model**

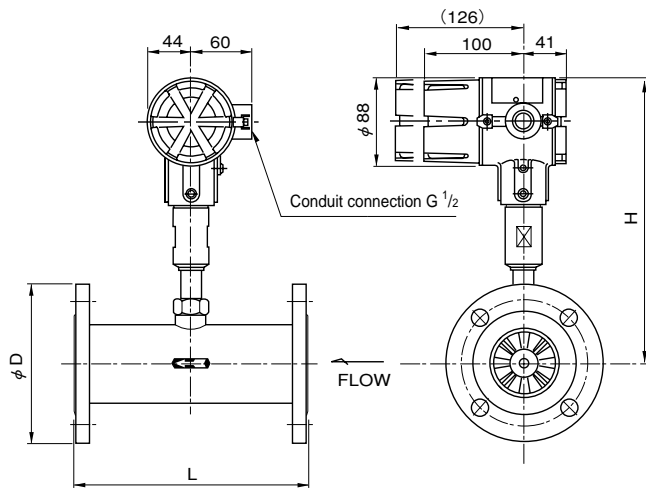

Nominal size : 15 to 50mm

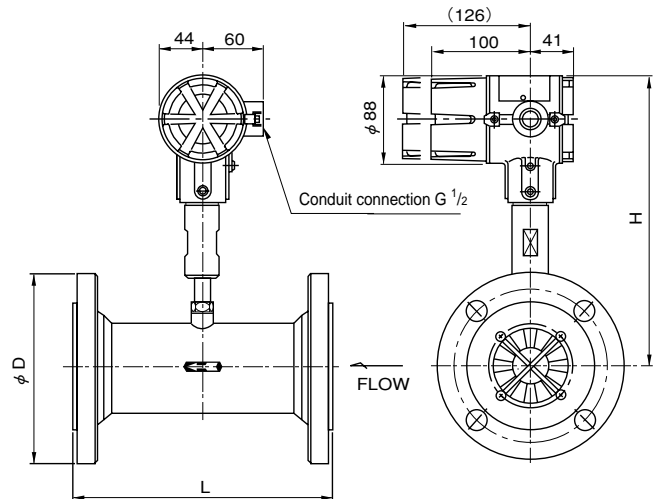

Nominal size : 80 to 400mm

● **High viscosity model, Low viscosity model**

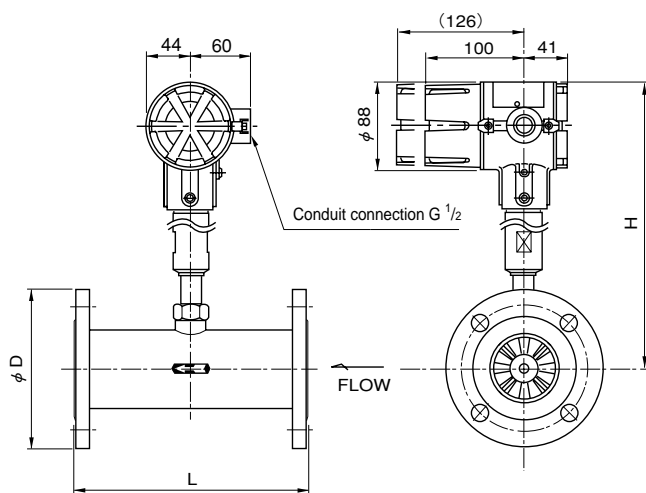

Nominal size : 15 to 50mm

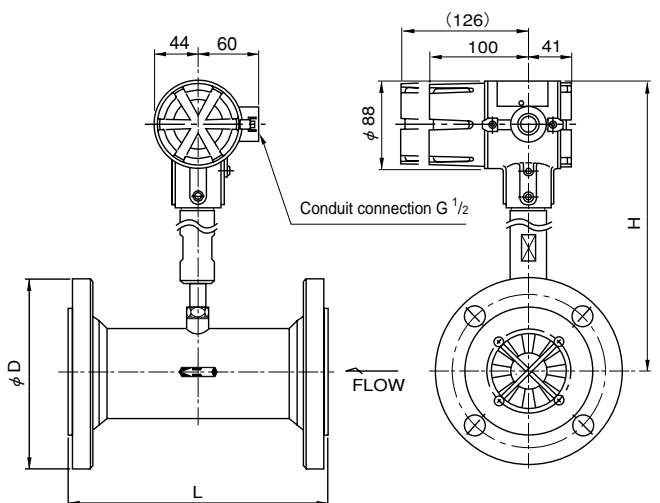

Nominal size : 80 to 400mm

● Converter w/PA14S

Dimensions are similar to w/PA14

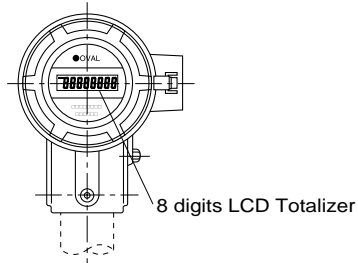

PA14S

PA14S w/totalizer is installed so that the cable entry points in the flow inlet direction.

PA can be oriented in any direction in 90° steps.

Refer to the instruction manual if changing the flow direction is desired.

Nominal size (mm)	Temp. class	øD (JIS 10K)	L (mm)	H (mm)	Approx. Weight (kg)	
					No direct reading register	w/Direct reading register
15	Standard	95	95	263	4.3	4.6
	High Tp., Low Tp.			413	5.0	5.3
20	Standard	100	152	265	4.3	4.6
	High Tp., Low Tp.			415	5.0	5.3
25	Standard	125	203	268	6.3	6.6
	High Tp., Low Tp.			418	7.0	7.3
40	Standard	140	229	275	8.3	8.6
	High Tp., Low Tp.			425	9.0	9.3
50	Standard	155	229	281	12.3	12.6
	High Tp., Low Tp.			431	13.0	13.3
80	Standard	185	254.0	293	13.5	13.8
	High Tp.			443	13.8	14.1
100	Standard	210	304.8	305	21.5	21.8
	High Tp.			455	21.8	22.1
150	Standard	280	355.6	330	26.5	26.8
	High Tp.			480	26.8	27.1
200	Standard	330	406.4	354	54.5	54.8
	High Tp.			504	54.8	55.1
250	Standard	400	508.0	377	90.5	90.8
	High Tp.			527	90.8	91.1
300	Standard	445	609.6	403	139.5	139.8
	High Tp.			553	139.8	140.1
350	Standard	490	711.2	422	190.0	190.3
	High Tp.			572	190.3	190.6
400	Standard	560	812.8	444	270.0	270.3
	High Tp.			594	270.3	270.6

■ INSTALLATION CONDITIONS

1. Standard piping instructions (for ±0.35% RD class)

For the design performance of EX Turbine, it is necessary to obtain uniform flow pattern of metering fluid upstream and downstream of the meter.

To be successful, the following piping arrangement guidelines should be observed. (Refer to ISO-5167 for piping arrangements Nos. 2, 3, 4, and 5.)

(1) Straight pipe section lengths recommended in ISO-5167 standards.

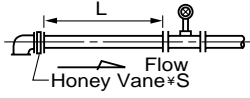
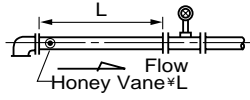
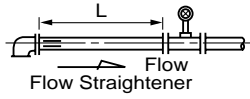
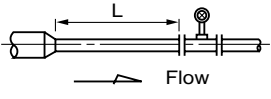
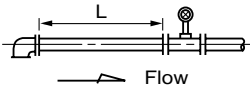
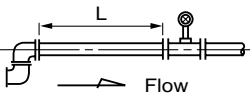
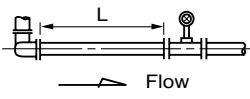
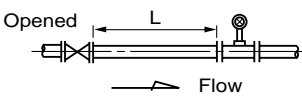
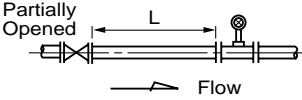
No.	Piping Arrangement	Straight Pipe Length (L) D = Nom. size	Remarks
1		8D	Refer to "Honey Vane" on page 11. Applicable to Nom. size >25mm
			
			
2		15D min.	A concentric reducer is upstream of the meter.
3		23D min.	An elbow is upstream of the meter.
		25D min.	Two elbows are vertically upstream of the meter.
		40D min.	Two elbows are horizontally upstream of the meter.
4		15D min.	A fully open valve is upstream of the meter.
5		50D min.	A partially open gate valve, sharp orifice, or something that markedly disturbs the flow pattern is upstream of the meter.

- Notes 3: 1) Sch.40 pipe is used as the standard material in the list.
 2) Downstream of the meter, be sure to install 5D straight pipe.
 3) Pressure or temperature detector shall be located downstream of the meter as shown in Fig. 3.

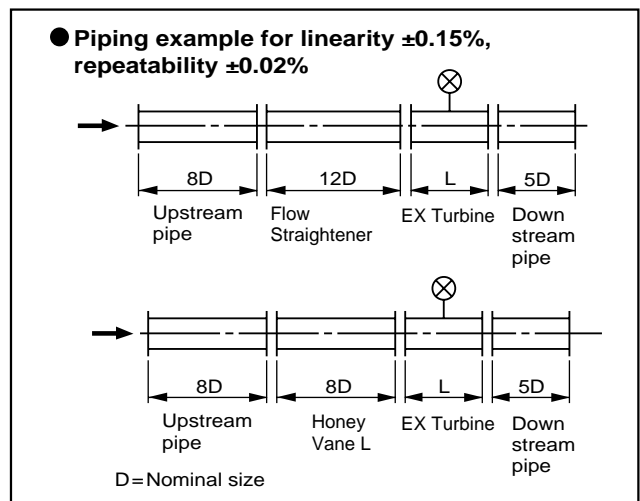
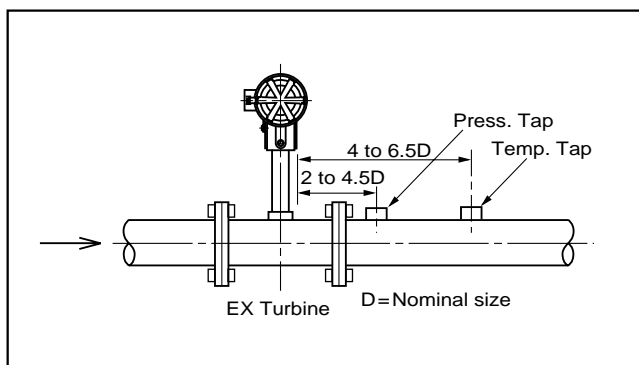

● **Requirements of backpressure for EX Turbine**

As the flow velocity increases in EX Turbine, cavitation could be produced. By cavitation, a meter error could also shift to + side and fluctuate considerably.

In order to prevent this, it is required to maintain a constant backpressure.

Thus, API-2534 specifies the required of backpressure in the following equation:

$$P_B \geq 2\Delta P + 1.25P_o \text{ (MPa [absolute])}$$

P_B : Back pressure
(Pressure at downstream pipe outlet)

ΔP : Pressure loss (MPa)

P_o : Vapor pressure of liquid to be metered.
(MPa [absolute])

● **Strainer**

Install a strainer upstream of the meter to prevent the meter from damage with foreign solids.

Where nominal size of EX Turbine is smaller than the piping nominal size, select a strainer having the same diameter as that of the pipeline.

(Usually, flow velocity in a strainer should be controlled to less than 4 to 5m/sec and the pressure to less than 29.4kPa).

Nominal sizes and net mesh are specified as follows:

Nominal Size (mm)	Standard Type	Hi Viscosity Type
15 to 80, 100	60 mesh	60 mesh
150	40 mesh	
Larger than 200	20 mesh	

● **Air Eliminator**

If any quantity or bubble is present in the liquid, metering error could considerably increase being not negligibly small. For this reason, installation of OVAL air eliminator up-stream of the meter is recommended.

● **Thermal Insulation**

If it is desired to thermally insulate the pipeline, simple lagging (without mortar finish) is suggested.

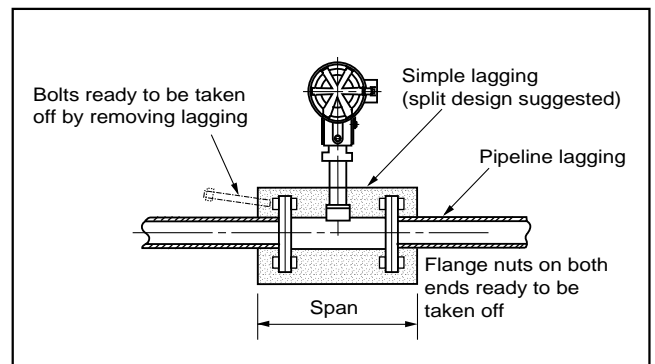

● **Honey Vane**

Dimensions

Nom. size (mm)	ϕD (※1) (mm)	Honey Vane-S	Honey Vane-L
		t (mm)	L (mm)
25	75	3.5	200
40	90	5.4	320
50	105	6.9	400
80	134	10.2	640
100	159	13.3	800
150	220	19.6	1200
200	268	26	1600
250	331	32.3	2000
300	376	38.7	2400

※1 : JIS10K

※ : Consult factory for larger than nominal size 350.

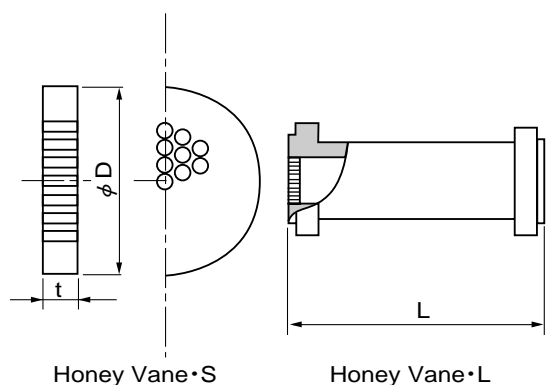

■ **When making inquiries, please advise the following:**

(Fill in blanks or check with ✓mark).

1. Application	
2. Fluid to be metered	
3. Flow range (m³/h)	Max. _____ Normal _____ Min. _____
4. Nominal size	_____ mm _____ inch
5. Temp. range (°C)	Max. _____ Normal _____ Min. _____
6. Pressure range	Max. _____ Normal _____ Min. _____ <input type="checkbox"/> MPa
7. Density or Sp. Gr.	Density _____ kg/m ³ Sp. Gr. _____
8. Flange rating	_____
9. Flow straightener	<input type="checkbox"/> Req'd <input type="checkbox"/> Not req'd
10. Converter	Model : <input type="checkbox"/> PA14 <input type="checkbox"/> PA14S Explosionproof construction : <input type="checkbox"/> Nonexplosionproof <input type="checkbox"/> Flameproof <input type="checkbox"/> Combination explosionproof (PA14S)
11. Output signal	<input type="checkbox"/> Unscaled pulse <input type="checkbox"/> Scaled pulse Pulse unit _____ L/P <input type="checkbox"/> Analog output Full scale _____ to _____ /h
12. Receiving instrument	<input type="checkbox"/> Direct-coupled LCD counter <input type="checkbox"/> Arrangement with receiving instruments
13. Miscellaneous	

The specification as of May, 2009 is stated in this GS Sheet. Specifications and design are subject to change without notice.



Sales Representative:
icenta CONTROLS Ltd
 North Station Yard, Warminster Road, Wilton, Salisbury, SP2 0AT
 Tel: 0845 895 1020 Fax: 0845 895 1021
 Email: sales@icenta.co.uk
 www.icenta.co.uk

GS.No.GBT103E

初版	改訂	印刷
----	----	----

△09.5

96.8	08.10	
------	-------	--