



FLOWPET-NX

(Oil Service Mechanical Register)

GENERAL SPECIFICATION
GS.No.GBB322E-17

■ GENERAL

Flowpet-NX is an OVAL flowmeter primarily developed for fuel oil measurement.

Field proven for consistent metering accuracy and long life combined with its ease of use and economy make this industrial instrument ideally suited for heat control applications as a dedicated flowmeter.

■ FEATURES

1. Mechanical register equipped model is also available which requires no power source for oil service.
2. Can furnish reliable pulses to a total counter and a high-speed pulse output to a flow indicator.



■ GENERAL SPECIFICATIONS

● Flow Ranges

Model	Nominal Size mm	Flange Rating	Flow Range, L/h		
			Kerosene (Above 0.8mPa·s to 2mPa·s)	Gas Oil (heavy oil A) (Above 2mPa·s to 5mPa·s)	Heavy oil (Above 5mPa·s to 200mPa·s)
LS5076-200A	20	JIS 10K RF	150 to 1600	80 to 2000	50 to 2000
LS5276-200A	25	JIS 10K RF	300 to 3000	150 to 3800	80 to 3800
LS5376-200A	40	JIS 10K RF	600 to 5000	300 to 6400	150 to 6400
LS5576-200A	40	JIS 10K RF	1200 to 11000	600 to 14000	400 to 14000
LS5676-200A	50	JIS 10K RF	2000 to 20000	1400 to 24000	900 to 24000

● Meter Body

Item	Description
Acceptable fluids	Kerosene, Light oil, Heavy oil (※Not serviceable with gasoline.)
Operating temp. range (fluid temp.)	0 to 120°C
Max. operating pressure	1.18MPa
Linearity	±0.35% of RD
Material	Body
	Rotors
Flow directions *	Right → left (standard), left → right, bottom → top, top → bottom
Coating color	Orange : Munsell 2.5 YR 6/13

⚠ Install the meter such that the pipe always remains filled with oil. See instruction manual if changing flow direction is desired.

OVAL Corporation

<http://www.oval.co.jp>

Head Office (Tokyo): Phone. 81-3-3360-5121. Fax. 81-3-3365-8605
Beijing Office: Phone. 86-10-5867-4711. Fax. 86-10-5867-4713
Overseas Branch Offices: Seoul, Singapore and Taipei

● Mechanical Register Specifications

Item	Description	
Model	LS5076, LS5276	LS5376, LS5576, LS5676
Functions	Cumulative counter with dial-and-pointer, 6-digit number wheels	
Display	One pointer rev.	1L 10L
	Resolution	0.01L 0.1L
	Counter capacity	999,999.99L 9,999,999.9L
Output Pulse	See next section.	
Operating Temp. Range	-10 to +60°C	
Construction	Waterproof conforming to IP65 (weathertight)	
Material	Resin/Aluminum die casting	
Finish (housing)	Munsell 4.9PB4.0/13.9 (color of molding)	

● Factored Pulse Generator in Mechanical Register (option)

Item	Description	
	MR sensor	Reed switch
Type of Output Pulse	Voltage pulse/open collector	Contact-closure pulse
Number of Pulses (per pointer rev.)	10 P	1 P
Pulse Width	1ms min.	—
Duty Factor	—	40/60 to 60/40
Output Signal Levels	Voltage pulse ON: 6.5V min. OFF: 1V max.	—
	Open collector ON: 1V max.	
Max. Operating Current	30mA	60mA (200Ω protective resistor provided)
Max. Operating Voltage	40V DC (open collector)	125V AC, 50V DC
Contact Bounce	—	0.5ms max.
Life	—	5 × 10 ⁷ cycles of operation (with resistive load at 12V DC, 10mA)
Signal Cable	Vinyl-insulated, 4-conductor, shielded (core wire 0.5mm ² , 4 to 10mm in O.D.)	
Transmission Distance	1 kilometer max. (using a CVVS cable 1.25 to 2.0mm ²)	
Power	12 to 24VDC ±10%	—
Current Drain	20mA max.	—

● Mechanical Register Pulse Output

Model	Nominal Size mm	MR Sensor		Reed Switch		Max. Flow Rate L/h
		Pulse Units	Pulse Units at Max. Flow Rate	Output Freq.	Pulse Units Output Freq. at Max. Flow Rate	
LS5076-200A	20	0.1 L/P	5.5 Hz	1 L/P	0.55 Hz	2000
LS5276-200A	25	0.1 L/P	10.5 Hz	1 L/P	1.05 Hz	3800
LS5376-200A	40	1 L/P	1.8 Hz	10 L/P	0.18 Hz	6400
LS5576-200A	40	1 L/P	3.8 Hz	10 L/P	0.38 Hz	14000
LS5676-200A	50	1 L/P	6.7 Hz	10 L/P	0.67 Hz	24000

■ OUTLINE DIMENSIONS [Unit in mm]

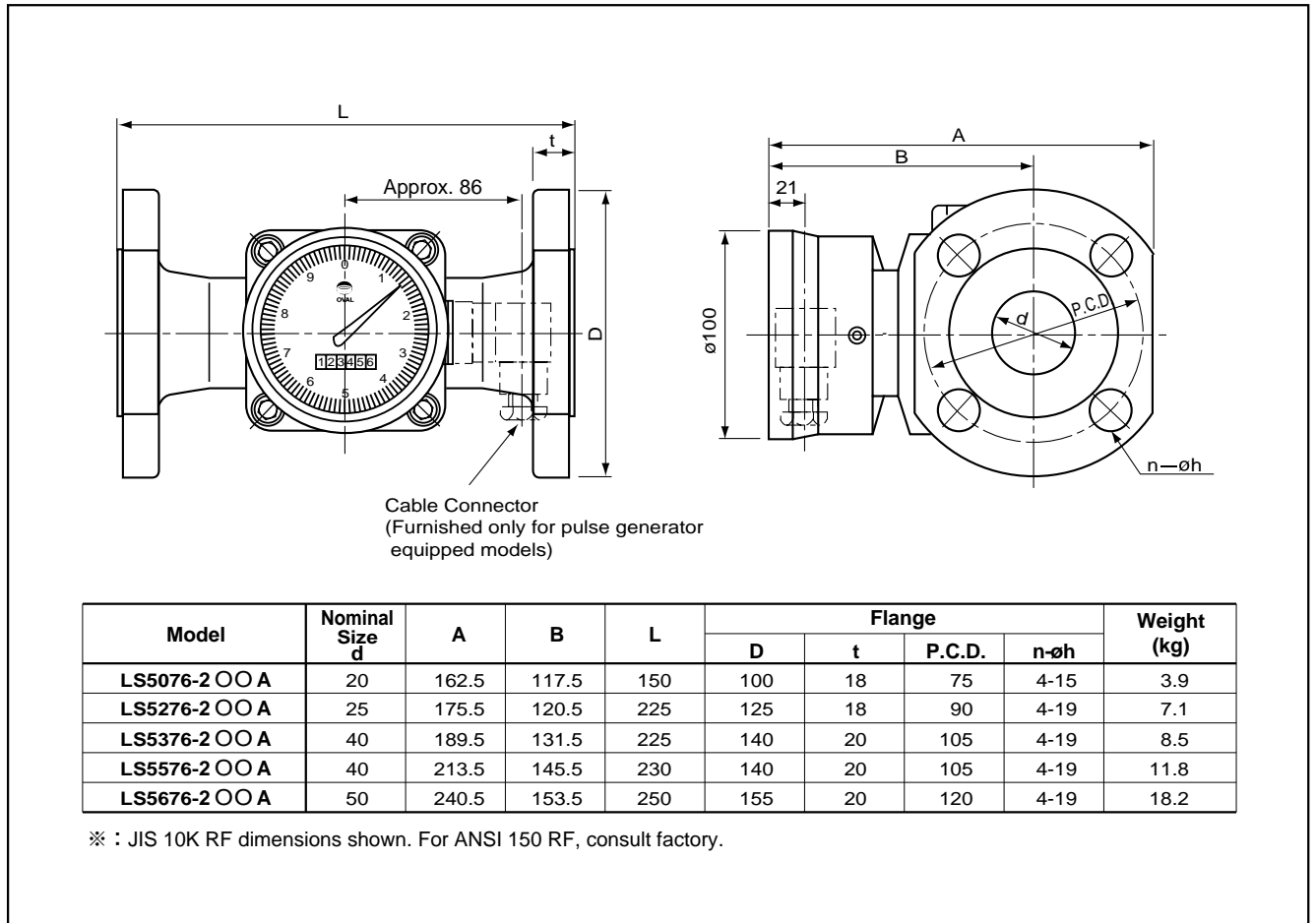

■ METER ERRORS AND PRESSURE LOSSES

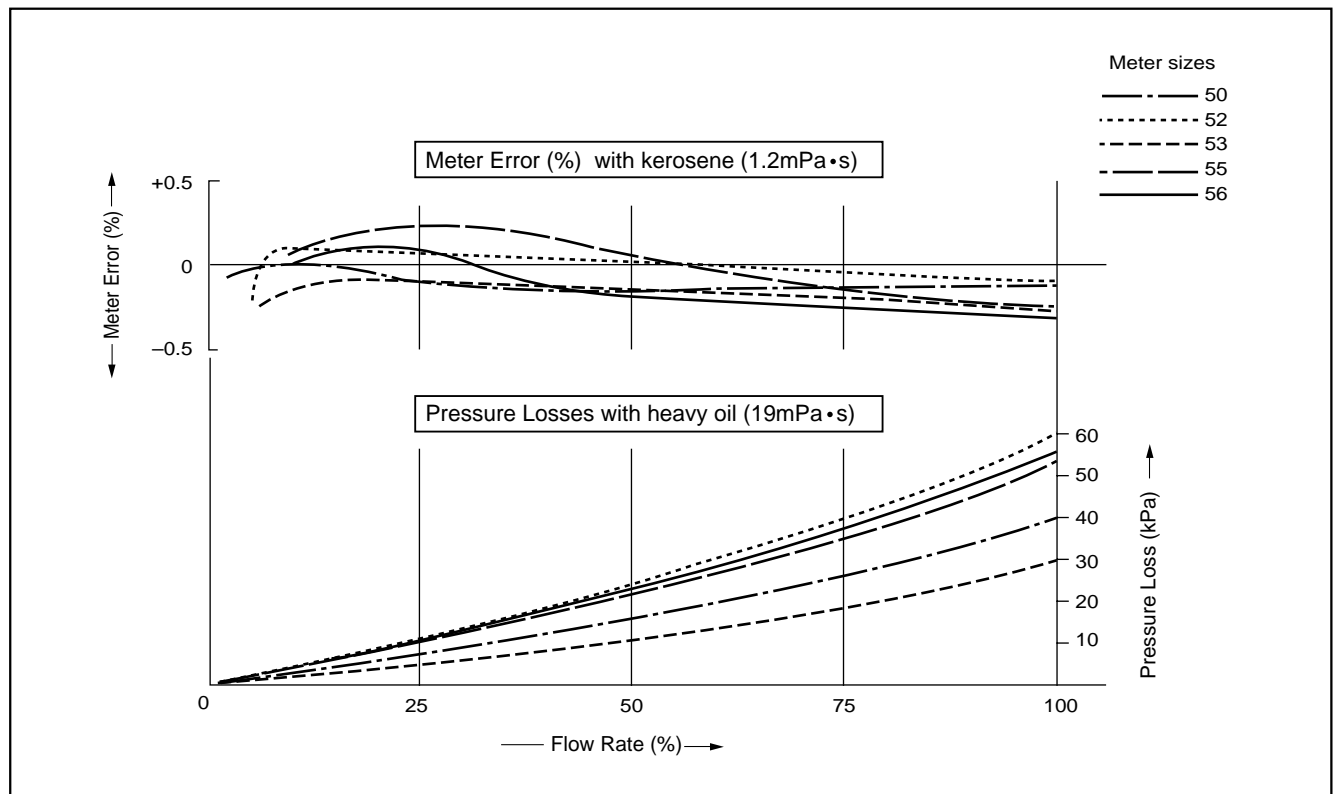

■ PRODUCT CODE EXPLANATION

Item	Product Code										Description	
	①	②	③	④	⑤	⑥	⑦	⑧	⑨	⑩		
Model	L	S										Dedicated OVAL flowmeter
Meter Size	5	0										20A JIS 10K RF
	5	2										25A JIS 10K RF
	5	3										40A JIS 10K RF
	5	5										40A JIS 10K RF
	5	6										50A JIS 10K RF
Model Name					7							Flowpet-NX
Application						6	-					Oil service
Register Type								2				Mechanical register
Units of Reading									1			L
									2			Gallons (option)
Pulse Generator									0			Non pulse generator (standard)
									1			Open-collector pulse generator provided. Factored pulse 10P/rev. (option)
									2			Voltage pulse generator provided. Factored pulse 10P/rev. (option)
									3			Contact-closure pulse generator provided. Factored pulse 1P/rev. (option)
Others										A		Always "A"

■ STRAINERS

● General

Do not fail to directly couple a strainer upstream of the Flowpet-NX.

A strainer safeguards the Flowpet-NX against foreign particles and other suspended matter which could cause costly downtime.

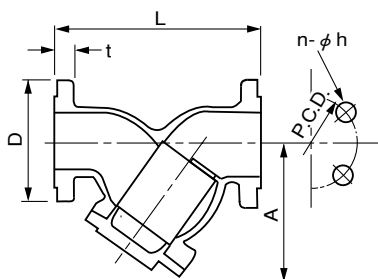

● Specifications

Item		Description
Operating Temp. Range (fluid temp.)		0 to 150°C
Max. Operating Pressure		1.18MPa
Material	Body	FC200
	Net	SUS304
Coating color		Orange : Munsell 2.5 YR 6/13

● Product Code, Outline Dimensions [Unit in mm], Net Mesh, Pressure Losses

Product Code Nom.	Nominal Size Flange Rating	L	A	Flange				Approx. Weight (kg)	Net Mesh	Pressure Loss (kPa) at Max. Flow Rate		Applicable Flowpet-NX
				D	t	P.C.D.	n-φh			Kerosene 1.2mPa·s	Heavy oil 19mPa·s	
SS5277A	20A JIS 10K RF	125	85	100	18	75	4-15	3.4	80	6(1600L/h)	50(2000L/h)	LS5076-2 OOA
SS5377A	25A JIS 10K RF	140	105	125	18	90	4-19	5.3	60	7(3000L/h)	28(3800L/h)	LS5276-2 OOA
SS5577A	40A JIS 10K RF	170	130	140	20	105	4-19	7.7	60	23(11000L/h)	26(14000L/h)	LS5376-2 OOA LS5576-2 OOA
SS5677A	50A JIS 10K RF	190	140	155	20	120	4-19	9.6	60	25(20000L/h)	40(24000L/h)	LS5676-2 OOA

■ REMOTE FLOW MEASUREMENT WITH FLOWPET-NX

Pulse generator equipped Flowpet-NX provides the operator with a quick indication of the process for absolute control of oil supply at a remote location.

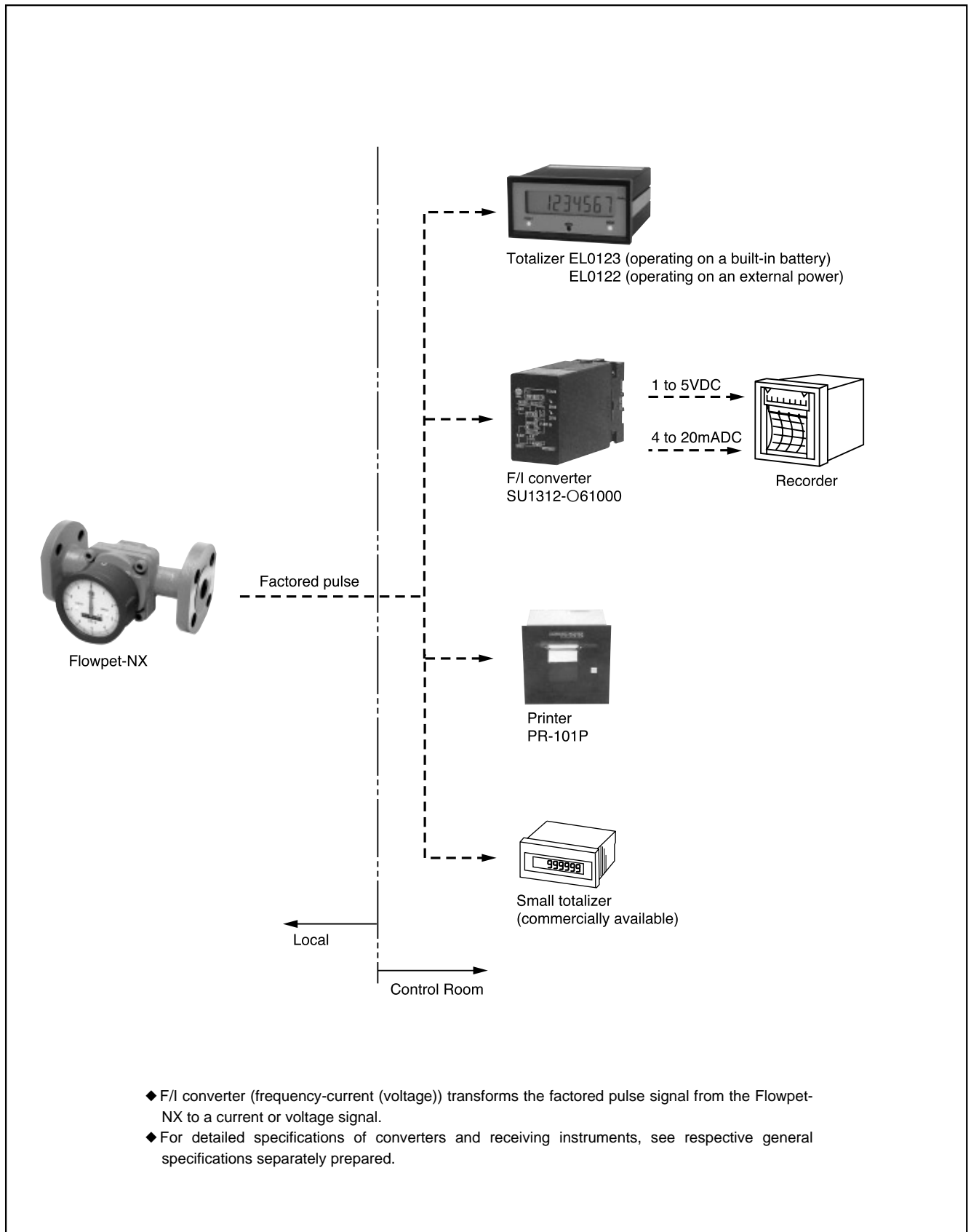

■ OPERATING PRECAUTIONS

To derive maximum benefit and safety of operation from the Flowpet-NX, we recommend that the following precautions be taken:

1. From the flow ranges and operating ranges of the flowmeter, strainer and other available data, select the right pump and valve location to ensure that the required flow rate, pressure and other factors be maintained and that excessive flow rates, pressure rises or other damaging conditions be prevented.
2. In cold regions, take due precautions against freezing.
The meter body and strainer are not serviceable at subzero temperatures.
3. Locate the flowmeter itself and signal cable sufficiently away from sources of large magnetic fields (e.g., pumps, electric motor-driven and solenoid valves).
(For example, keep a solenoid valve 10 watts or so in power consumption at least 10 centimeters away.)
4. Acceptable fluids depend on the type of flowmeter. The Flowpet-NX is primarily designed for boiler feed water and fuel oil. If you have any other application in mind, seek our service for application assistance.

The specification as of Nov, 2010 is stated in this GS Sheet. Specifications and design are subject to change without notice.



Sales Representative:
icenta CONTROLS Ltd
North Station Yard, Warminster Road, Wilton, Salisbury, SP2 0AT
Tel: 0845 895 1020 Fax: 0845 895 1021
Email: sales@icenta.co.uk
www.icenta.co.uk

GS.No.GBB322E

初版	改訂	印刷
99.1	10.11	