

Fig. 1 F VA Tubux variable area meter

Application

The F VA Tubux variable area meters are used to measure the volume of transparent liquids and gases passing through closed piping. The variable area meters can also be used for flow monitoring if they are equipped with one or more switching contacts. Standard scales are available for liquids with a density of 1 kg/l (62,43 lb/cu.ft). The scales must be recalculated for all other media depending on the physical characteristics.

The flow tube is also optionally available with a percentage or 2-mm (0.078 inch) scale.

Design and operation

The main components of the F VA Tubux variable area meters are the glass variable-area flow tube with float, the fitting and the connection parts. The flow is displayed directly on the scale present on the flow tube (e.g. in l/h) and is read at the position of the float's widest diameter.

Benefits

Product scales for liquids and gases

- Rugged versions with various materials
- Can be used for high pressures and temperature
- Short delivery times for standard versions.

Connection and mode of operation

For certain variable area meter sizes, the float is packed in a plastic net for transport purposes. Prior to fitting, this must be removed out of the variable area meter from the top.

The locking rod must be pulled upwards out of the variable area meter.

In versions with a float guide rod, the float is usually held in place at the top by a rubber buffer. Push this buffer down to the bottom limit by pressing on the float.

The variable area meter must be fitted vertically and without tension. Control elements or reductions/extensions in the pipe diameter upstream or downstream of the variable area meter have no influence on the accuracy when measuring liquids. However, when measuring gases, the variable area meter should be installed upstream of valves to prevent pulsations resulting from compression. Since variable area meters respond extremely sensitively to changes in flow, control elements should always be adjusted slowly.

The calibration has been carried out for defined media conditions. Deviations in the density, pressure or temperature of gases, or in the density or viscosity of liquids, result in measurement errors. It is essential to observe the calibration conditions. When ordering, it is therefore essential to provide data on the medium, density and viscosity at the operating temperature and pressure. With gases, it is additionally necessary to specify the exact reference point for the pressure (pressure above atmospheric, or absolute pressure).

Retrofitting of switching contacts is only possible if variable area meters with magnets are used and if the fitting is made of stainless steel (see Table Versions). When using for the first time, move the float completely past the contact to permit polarization.

Float guide rod (see also tables on page 4 and 5)

The float guide rod prevents the float from making contact with the glass flow tube.

The option is recommended to increase the operational safety and to protect against glass breakages in the case of operating conditions such as solenoid valve control. The option is not possible in conjunction with floats with magnets and weighted PVC/PVDF floats.

Liquids: Standard: flow tube E 4000 to H 25000
Option: flow tube C 125 and upwards

Gases: Standard: flow tube D 2500 to H 25000
Option: flow tube C 125 and upwards

Note of application

The operator of these measuring instruments is responsible for suitability, proper use and corrosion resistance of the used materials with regard to the measuring material. It must be ensured that the materials selected for the flowmeter parts in contact with the medium are suitable for the used process media. The flowmeter may only be used within the pressure and voltage limits specified in the operating instructions. Before replacing the measuring tubes, check that the unit is free of hazardous media and pressures. Provide a touch guard for surface temperatures of > 70°C. This touch guard must be designed in a way that the max. allowable ambient temperature on the unit is not exceeded. The flowmeter meets the requirements of the PED 97/23/EG as stated in the table as follows.

Classification according to PED 97/23/EC

	Order No. 7ME5810-	Permissible media	Category
G1/4 to G3	xxxxx-xxxx; a≠2	Gases of fluid group 2 and liquids of fluid group 1	Article 3.3
≤DN25 (G1/4 to G1)	xxxxx-xxxx; a=2	Gases of fluid group 1 and liquids of fluid group 1	Article 3.3
>DN25 (G1 1/4 to G3)	xxxxx-xxxx; a=2	Gases of fluid group 1 and liquids of fluid group 1	I

Variable area meter F VA Tubux

Versions

Eight standard versions are defined in the price list using different combinations of fittings, connection materials and floats (the type number corresponds to the 4th digit of the second block of the order number).

Version	Type 1	Type 2	Type 3	Type 4	Type 5	Type 6	Type 7	Type 8
Can be used for	liquids					gases		
Fitting	steel	Mat. No. 1.4571/316 Ti	steel	PVC	Mat. No.1.4571/316Ti/steel	steel	steel	Mat. No.1.4571/316Ti/steel
Connection	steel (cast iron)	Mat. No. 1.4571/316 Ti	Mat.No. 1.4571/316Ti	PVC	steel	steel (cast iron)	Mat. No. 1.4571/316Ti	Steel (cast iron)
Float	Mat. No. 1.4571/316Ti, 1.4305/303	Mat. No. 1.4571/316Ti	Mat. No. 1.4571/316Ti	PVC weighted	Mat. No. 1.4571/316Ti	Aluminium (PVC and PVDF as special version)		Aluminium (PVC as special version)
Magnet	-	-	-	-	X	-	-	X
Flow tube, size	A and B	X	X	X	X	-	X	X
	C to F	X	X	X	X	X	X	X
	G and H	X	-	X	-	X	X	X

Standard variable area meter versions

Selection of float

There are three versions of floats

- Non-guided float
- Guided float
- Viscosity-compensated float.

Use of the viscosity-compensated float is necessary above the following viscosities:

Flow tube	mPa·s
C 125 to C 500	≥ 3
D 650 to D 3000	≥ 5
E 4000 to F 10000	≥ 8
G 12500 to H 25000	≥ 10

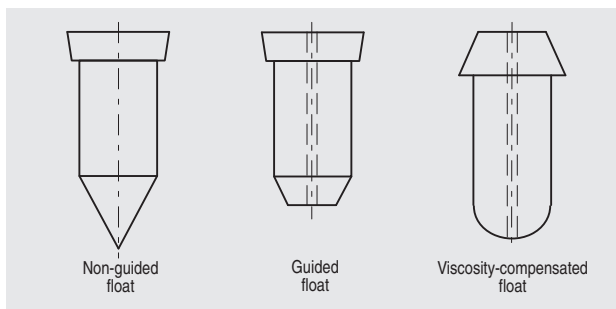
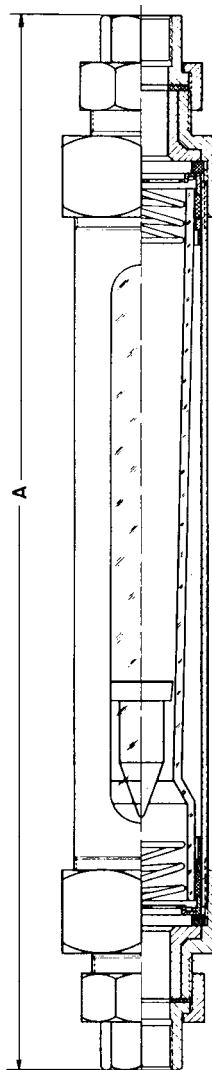

Fig. 2 Float versions

Dimensions



Connection	A [mm] ± 4 mm (A [inch] ± 0.16 inch)
G½	405 (15.94)
G1	435 (17.13)
G2	455 (17.91)
G3	470 (18.50)

Fig. 3 F VA Tubux, dimensions in mm (inch)

Variable area meter F VA TUBUX

Technical specifications

Application	See page 1
Mode of operation	See page 1
Measuring principle	Float

Input

Flow	Vertically upwards
Pressure limit with threaded connection	
• Flow tubes A 1 to D 3.000	Max. 10 bar / 145 psi
• Flow tubes E 4.000 to F 10.000	Max. 8 bar / 116 psi
• Flow tubes G 12.500 to H 25.000	Max. 5 bar / 73 psi

Rated operating conditions

Temperature limits

• With Float made of Mat. No. 1.4305 / 303 or 1.4571 / 316Ti or aluminium	-10 to +150 °C / 14 to 302 °F
• With float made of PVDF	-10 bis +100 °C / 14 to 212 °F
• With float made of PVC	-10 bis +50 °C / 14 to 122 °F
• With fitting made of PVC	-10 bis +50 °C / 14 to 122 °F

Engraved scale is necessary with medium temperature >90 °C / 194 °F

Medium conditions

• Accuracy	Class 1,6 (according to VDE/VDI 3513, sheet 2)
• Measuring range	Dependent on flow tube See tables on page 4 and 5
- For liquids	0,1 l/h to 25 m ³ /h / 0,00044 to 110 USgpm
- For gases	1,6 l/h to 400 m ³ /h / 0,006 to 450.000 scfm

A special scale must be provided for liquids with a density other than 1 kg/l / 62,43 lb/cu.ft and all gases

• Dimensions for measured variable
l/h (up to flow tube D2500)
m³/h (flow tube D3000 and above)

Design

Connections	Screwed gland G¼ to G3
Material	
• Flow tube	Borosilicate glass (length 300 mm (11.8 inch))
• Connection	Cast iron, stainless steel, mat. No. 1.4571 / 316Ti, steel/PVC
• Float	Stainless steel, mat. No. 1.4305 / 303, mat. No. 1.4571 / 316Ti, PVC and PVDF, aluminium
• Float guide rod	Stainless steel mat. No. 1.4571 / 316Ti
• Gasket	Buna N up to 90 °C / 194 °F, Viton up to 150 °C / 302 °F, EPDM (for potable water plants) up to 150 °C / 302 °F
• Limit	Springs made of stainless steel for non-guided floats, otherwise rubber buffers for guided floats
Weight	
• With threaded connection G½	2,5 kg (5,51 lb)
• With threaded connection G1	5,5 kg (12,12 lb)
• With threaded connection G2	9 kg (19,8 lb)
• With threaded connection G3	24 kg (52,9 lb)

Fittings and Connections PVC DIN 8062

Medium	T [°C(F)]	P _a [bar(psi)]
Water and not abrasive liquids	20 (68)	10,0 (145)
	40 (104)	10,0 (145)
	50 (122)	2,5 (36)
abrasive liquids	20 (68)	10,0 (145)
	40 (104)	4,0 (58)
	50 (122)	1,0 (15)

Technical specifications of contacts

Switching principle	Magnetic contact unit, bistable
Designation	
• Flow tube size C 125 to H 25000	K17 A, K17 B
• Flow tube size D 650 to H 25000	K 23
Housing/plug	PP/PA 6
Contact material	Rhodium
Degree of protection	IP65
Ambient temperature	-20 to +80 °C / -4 to 176 °F
Max. switching frequency	5/min
Max. rating	
• K 17	AC 250 V/0,5 A/10 VA DC 250 V/0,5 A/5 W
• K 23	AC 250 V/1 A/150 VA DC 250 V/1 A/100 W Rating data apply to resistive loads; a suppressor circuit is required for inductive loads

Contact assembly

The bistable contact assembly consists of a contact spring set sealed in a glass tube filled with protective gas.

Three contacts can be selected:

- K 17 A: contact closes when the limit is fallen below
- K 17 B: contact closes when the limit is exceeded
- K 23: changeover contact.

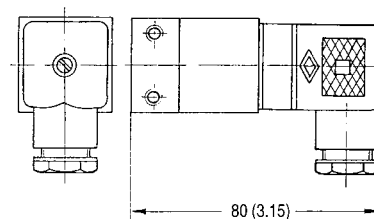

Fig. 4 Contact K17, dimensions in mm (inch)

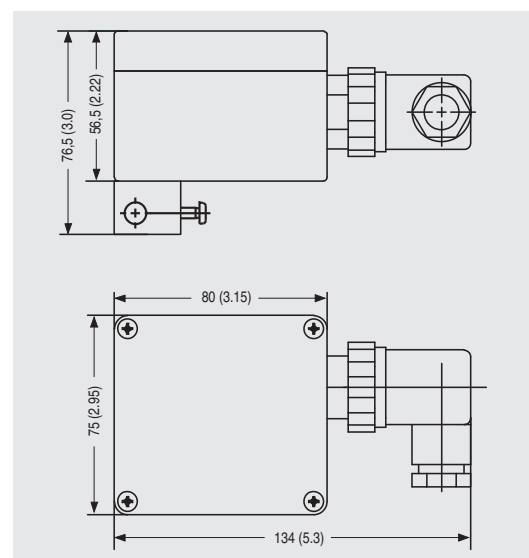

Fig. 5 Changeover contact K23, dimensions in mm (inch)

Variable area meter F VA Tubux

Measuring ranges for liquids

Standard measuring range for liquid ($\rho = 1\text{ kg/l}$ (62,43) lb/cu.ft, viscosity 1 mPa-s (1cp)) (dynamic range 1:10)

Connection	Flow tube	Pressure loss	Max. Measuring range for the selected floats								
			Up to flow tube B100, mat. No.		Viscosity-compensated, mat. No.		With magnet, mat. No.		PVC weighted		
Female thread G, NPT	PVC adhesive bushing		mbar (psi)	1.4305, 1.4571	303,316Ti	1.4571	316Ti	1.4571	316Ti		
				l/h	(USgpm)	l/h	(USgpm)	l/h	(USgpm)	l/h	(USgpm)
(G1/4), (G3/8), G1/2	20 (0,79)	A 1	10 (0,145)	1	(0,0044)	-	-	-	-	-	-
		A 3		3	(0,013)	-	-	-	-	-	-
		A 5		5	(0,022)	-	-	-	-	-	-
		A 10		10	(0,044)	-	-	-	-	-	-
		A 25		25	(0,110)	-	-	-	-	-	-
		B 30		30	(0,132)	-	-	-	-	11	(0,048)
		B 40		40	(0,176)	-	-	-	-	15	(0,066)
		B 50		50	(0,22)	-	-	-	-	20	(0,088)
		B 65		65	(0,29)	-	-	-	-	25	(0,110)
		B 80		80	(0,35)	-	-	-	-	32	(0,140)
		B 100	100	(0,44)	-	-	-	-	40	(0,176)	
		C 125	20 (0,290)	125	(0,55)	100*	(0,44)*	120	(0,53)	65	(0,29)
		C 160		160	(0,70)	125*	(0,55)*	150	(0,66)	90	(0,40)
		C 200		200	(0,88)	160*	(0,70)*	180	(0,79)	110	(0,48)
		C 250		250	(1,10)	200*	(0,88)*	240	(1,06)	140	(0,62)
		C 315	40 (0,58)	315	(1,39)	240*	(1,06)*	300	(1,32)	175	(0,77)
C 400	400	(1,76)		300*	(1,32)*	360	(1,59)	220	(0,97)		
C 500	500	(2,20)		360*	(1,59)*	480	(2,11)	250	(1,10)		
(G1/2), (G3/4), G1	32 (1,26)	D 650	19 (0,28)	650	(2,86)	400*	(1,76)*	600	(2,64)	500	(2,20)
		D 800		800	(3,52)	500*	(2,20)*	750	(3,30)	600	(2,64)
		D 1000		1000	(4,4)	600*	(2,64)*	950	(4,18)	750	(3,30)
		D 1250		1250	(5,5)	750*	(3,30)*	1200	(5,3)	1000	(4,40)
		D 1600	24 (0,35)	1600	(7,0)	1000*	(4,40)*	1500	(6,6)	1250	(5,50)
		D 2000		2000	(8,8)	1200*	(5,30)*	1800	(7,9)	1600	(7,0)
		D 2500	33 (0,48)	2500	(11,0)	1400*	(6,20)*	2400	(10,6)	2000	(8,8)
		D 3000		3000	(13,2)	1800*	(7,9)*	2800	(12,3)	2400	(10,6)
(G11/4), (G11/2), G2	63 (2,48)	E 4000	25 (0,36)	4000*	(17,6)*	2500*	(11,0)*	3800*	(16,7)*	3200	(14,0)
		E 5000		5000*	(22,0)*	3000*	(13,2)*	4800*	(21,1)*	3800	(16,7)
		E 6500		6500*	(28,6)*	4000*	(17,6)*	6400*	(28,2)*	5000	(22,0)
		F 8000		8000*	(35,2)*	4500*	(19,8)*	7500*	(33,0)*	6400	(28,2)
		F 10000		10000*	(44,0)*	5500*	(24,2)*	9500*	(41,8)*	7500	(33,0)
(G2), (G21/2), G3	-	G 12500	34 (0,49)	12500*	(55,0)*	7000*	(30,8)*	12000*	(52,8)*	-	-
		G 16000		16000*	(70,4)*	9000*	(39,6)*	16000*	(70,4)*	-	-
		H 20000	38 (0,55)	20000*	(88,0)*	11000*	(48,4)*	18000*	(79,2)*	-	-
		H 25000		25000*	(110,0)*	14000*	(61,6)*	24000*	(105,6)*	-	-

*Guided float.

Non-standard sizes for the thread are listed in brackets.
Standard versions are bold printed.

Variable area meter F VA TUBUX

Measuring ranges for air

Standard measuring range for air ($\rho_{\text{abs}} = 1,013 \text{ bar (14,69 psi)}$ bei $T = 0^\circ\text{C (32}^\circ\text{F)}$, $\rho = 1,293 \text{ kg/m}^3$, $v = 0,0181 \text{ mPa.s}$) (dynamic range 1:10)

Connection	Flow tube	Pressure loss	Max. measuring range for the selected floats											
			Aluminium, mat. Nr. 3.1645		Aluminium, mat. Nr. 3.1645 with magnet		PVC		PVDF		PVC with magnet			
Female thread G, NPT	PVC adhesive bushing		mbar	(psi)	(l/h)	(scfm)	(l/h)	(scfm)	(l/h)	(scfm)	(l/h)	(scfm)	(l/h)	(scfm)
(G1/4), (G3/8), G1/2	20 (0,79)	A 1	4 (0,058)	16	(0,009)	-	-	10	(0,006)	10	(0,006)	-	-	
		A 3		50	(0,029)	-	-	25	(0,015)	25	(0,015)	-	-	
		A 5		80	(0,047)	-	-	50	(0,029)	50	(0,029)	-	-	
		A 10		160	(0,094)	-	-	80	(0,047)	80	(0,047)	-	-	
		A 25		400	(0,235)	-	-	250	(0,147)	250	(0,147)	-	-	
		B 30		500	(0,294)	-	-	320	(0,188)	360	(0,212)	-	-	
		B 40		650	(0,383)	-	-	450	(0,265)	500	(0,294)	-	-	
		B 50		800	(0,471)	-	-	550	(0,324)	650	(0,383)	-	-	
		B 65		1100	(0,647)	-	-	750	(0,441)	800	(0,471)	-	-	
		B 80		1400	(0,824)	-	-	900	(0,530)	1000	(0,589)	-	-	
		B 100	1600	(0,942)	-	-	1100	(0,647)	1250	(0,736)	-	-		
		C 125	6,5 (0,094)	2000	(1,18)	2500	(1,47)	1400	(0,824)	1500	(0,883)	2200	(1,29)	
		C 160		3000	(1,77)	3200	(1,88)	1800	(1,06)	2000	(1,18)	3000	(1,77)	
		C 200		3600	(2,12)	4000	(2,35)	2200	(1,29)	2500	(1,47)	3600	(2,12)	
		C 250		4000	(2,35)	5000	(2,94)	2800	(1,65)	3000	(1,77)	4500	(2,65)	
		C 315		15 (0,218)	5000	(2,94)	6400	(3,77)	3400	(2,00)	3600	(2,12)	6000	(3,53)
		C 400	6400		(3,77)	8000	(4,71)	4000	(2,35)	5000	(2,94)	7000	(4,12)	
C 500	8000*	(4,71)*	-		-	5000*	(2,94)*	5500*	(3,24)*	-	-			
(G1/2), (G3/4), G1	32 (1,26)	D 650	7 (0,102)	10000	(5,89)	12000	(7,06)	7000	(4,12)	8000	(4,71)	10000	(5,89)	
		D 800		13000	(7,65)	15000	(8,83)	9000	(5,30)	9000	(5,30)	12000	(7,06)	
		D 1000		16000	(9,42)	20000	(11,77)	11000	(6,47)	12000	(7,06)	16000	(9,42)	
		D 1250		20000	(11,77)	24000	(14,13)	14000	(8,24)	15000	(8,83)	20000	(11,77)	
		D 1600	9 (0,131)	28000	(16,48)	32000	(18,83)	18000	(10,59)	20000	(11,77)	25000	(14,71)	
		D 2000		36000	(21,19)	40000	(23,54)	22000	(12,95)	25000	(14,71)	32000	(18,83)	
		D 2500		40000*	(23,54)*	-	-	28000*	(16,48)*	30000	(17,66)*	-	-	
D 3000	50000*	(29,43)*	-	-	32000*	(18,83)*	36000	(21,19)*	-	-				
(G11/4), (G11/2), G2	63 (2,48)	E 4000	10 (0,145)	64000*	(37,67)*	75000*	(44,14)*	45000	(26,49)	50000	(29,43)	60000	(35,31)	
		E 5000		80000*	(47,09)*	100000*	(58,86)*	55000	(32,37)	65000	(38,26)	80000	(47,09)	
		E 6500		100000*	(58,86)*	125000*	(73,57)*	75000	(44,14)	80000	(47,09)	100000	(58,86)	
		F 8000		140000*	(82,4)*	150000*	(88,29)*	90000	(52,97)	100000	(58,86)	125000	(73,57)	
		F 10000		160000*	(94,17)*	180000*	(105,9)*	120000	(70,63)	125000	(73,57)	160000	(94,17)	
(G2), (G21/2), G3	-	G 12500	13 (0,189)	200000*	(117,7)*	220000*	(129,5)*	130000*	(76,52)*	150000*	(88,29)*	175000*	(103,0)*	
		G 16000		280000*	(164,8)*	300000*	(176,6)*	180000*	(105,9)*	200000*	(117,7)*	240000*	(141,3)*	
		H 20000	14 (0,203)	320000*	(188,3)*	360000*	(211,9)*	220000*	(129,5)*	250000*	(147,1)*	300000*	(176,6)*	
		H 25000		400000*	(235,4)*	450000*	(264,9)*	280000*	(164,8)*	300000*	(176,6)*	360000*	(211,9)*	

*Guided float.

Non-standard sizes for the thread are listed in brackets.
Standard versions are bold printed.

Variable area meter

F VA Tubux

Selection and ordering data

F VA Tubux variable area meter		7ME5810-	-	↑↑↑↑↑	↑↑↑↑↑	↑↑↑↑↑
Glass flow tube				↑↑↑↑↑	↑↑↑↑↑	↑↑↑↑↑
Flow tube size				↑↑↑↑↑	↑↑↑↑↑	↑↑↑↑↑
A	1	1	A A	↑	↑	↑
A	3	2	A A	↑	↑	↑
A	5	3	A A	↑	↑	↑
A	10	4	A A	↑	↑	↑
A	25	5	A A	↑	↑	↑
B	30	1	B A	↑	↑	↑
B	40	2	B A	↑	↑	↑
B	50	3	B A	↑	↑	↑
B	65	4	B A	↑	↑	↑
B	80	5	B A	↑	↑	↑
B	100	6	B A	↑	↑	↑
C	125	1	C C	↑	↑	↑
C	160	2	C C	↑	↑	↑
C	200	3	C C	↑	↑	↑
C	250	4	C C	↑	↑	↑
C	315	5	C C	↑	↑	↑
C	400	6	C C	↑	↑	↑
C	500	7	C C	↑	↑	↑
D	650	1	D D	↑	↑	↑
D	800	2	D D	↑	↑	↑
D	1000	3	D D	↑	↑	↑
D	1250	4	D D	↑	↑	↑
D	1600	5	D D	↑	↑	↑
D	2000	6	D D	↑	↑	↑
D	2500	7	D D	↑	↑	↑
D	3000	8	D D	↑	↑	↑
E	4000	1	E E	↑	↑	↑
E	5000	2	E E	↑	↑	↑
E	6500	3	E E	↑	↑	↑
F	8000	1	F E	↑	↑	↑
F	10000	2	F E	↑	↑	↑
G	12500	1	G G	↑	↑	↑
G	16000	2	G G	↑	↑	↑
H	20000	1	H G	↑	↑	↑
H	25000	2	H G	↑	↑	↑
Version						
• Type 1		1				
Fitting: steel						
Connection: steel (cast iron)						
Float: 1.4571/316Ti / 1.4305/303						
• Type 2		2				
Fitting: 1.4571, 316Ti						
Connection: 1.4571, 316Ti						
Float: 1.4571, 316Ti						
• Type 3		3				
Fitting: steel						
Connection: 1.4571/316Ti						
Float: 1.4571/316Ti						
• Type 4		4				
Fitting: PVC						
Connection: PVC						
Float: PVC, weighted						
• Type 5		5				
Fitting: 1.4571/steel, 316Ti						
Connection: steel (cast iron)						
Float: 1.4571/316Ti with magnet						
• Type 6		6				
Fitting: steel						
Connection: steel (cast iron)						
Float: aluminium or PVC ³⁾ or PVDF ³⁾						
• Type 7		7				
Fitting: steel						
Connection: 1.4571/316Ti						
Float: aluminium or PVC ³⁾ or PVDF ³⁾						
• Type 8		8				
Fitting: 1.4571/steel, 316Ti						
Connection: steel (cast iron)						
Float: aluminium or PVC ³⁾ with magnet						

³⁾ Available as special version

Selection and ordering data

F VA Tubux variable area meter		7ME5810-	-	↑↑↑↑↑	↑↑↑↑↑	↑↑↑↑↑	↑↑↑↑↑
Glass flow tube				↑↑↑↑↑	↑↑↑↑↑	↑↑↑↑↑	↑↑↑↑↑
Gasket material							
• Buna N		1					
• Viton		4					
• EPDM		8					
Contacts (only with magnetic float)							
• without contact		0					
• contact K17/A (closes when limit is falling below)		1					
• contact K17/B (closes when limit is exceeded)		2					
• 2 contacts K17/A		3					
• 2 contacts K17/B		4					
• Changeover contact K23		5					
• 1 per contact K17/A and K17/B		6					
Connection size (see page 4)							
• PVC adhesive bushing (for plastic pipe only)		A					
• female thread G1/4		B					
• female thread G3/8		C					
• female thread G1/2		D					
• female thread G3/4		E					
• female thread G1		F					
• female thread G1 1/4		G					
• female thread G1 1/2		H					
• female thread G2		J					
• female thread G2 1/2		K					
• female thread G3		L					
Connection type							
• female thread DIN ISO 228 ¹⁾		A					
• adhesive bushing (only for Type		B					
• female thread (NPT) ¹⁾		C					
Float version							
• standard		0					
• guided		2					
• float viscosity-compensated for liquids (SV)		3					
• PVC for gases		4					
• PVC with magnet for gases		5					
• PVDF for gases		6					
• PVC guided		7					
• PVDF guided		8					
• special version, specify order code and plain text		9					
Further designs							
Please add "-Z" to order No. and specify order code(s).							
Y01	measured medium, always required, specify in plain text: medium, measuring range with dimension, density with dimension viscosity with dimension, operating temperature, operating pressure						
Y02	with engraved scale (>90°C /194°F)						
Y04	Silicone-free version						
Y05	water as measured medium viscosity: 1mPas (cp), density: 1 kg/l (62,43 lb/cu.ft)						
Y99	special version, specify in plain text ¹⁾ with Type 4: material PVC.						

R 1 Y