



Fig. 1 F VA Unox, variable area meter

Application

The F VA Unox variable area meters are used to measure the volume of transparent liquids and gases passing through closed piping. The variable area meters can also be used for flow monitoring if they are equipped with one or more switching contacts. Standard scales are available for liquids with a density of 1 kg/l (62.43 lb/cu.ft). The scales must be recalculated for all other media depending on the physical characteristics.

The measuring accuracy corresponds to class 1.6 according to VDE/VDI 3513, page 2.

Design and operation

The main components of the F VA Unox variable area meters are the glass variable-area flow tube with float and the connection parts. The flow is displayed directly on the scale present on the flow tube (e.g. in l/h). The flow tube is optionally available with a percentage or 2-mm (0.079 inch) scale.

The flow is read at the position of the float's widest diameter.

Benefits

- Product scales for liquids and gases
- Fast installation/removal of the flow tube possible without removal of the fitting
- Increased protection of users from glass breakages by additional cover with single-pane safety glass.

Note of application

The operator of these measuring instruments is responsible for suitability, proper use and corrosion resistance of the used materials with regard to the measuring material. It must be ensured that the materials selected for the flowmeter parts in contact with the medium are suitable for the used process media. The flowmeter may only be used within the pressure and voltage limits specified in the operating instructions. Before replacing the measuring tubes, check that the unit is free of hazardous media and pressures. Provide a touch guard for surface temperatures of > 70°C. This touch guard must be designed in a way that the max. allowable ambient temperature on the unit is not exceeded. The flowmeter meets the requirements of the PED 97/23/EG as stated in the table on page 2.

Connection and mode of operation

The variable area meter must be fitted vertically and without tension. Control elements or reductions/extensions in the pipe diameter upstream or downstream of the variable area meter have no influence on the accuracy when measuring liquids. However, when measuring gases, the variable area meter should be installed upstream of valves to prevent pulsations resulting from compression. Since variable area meters respond extremely sensitively to changes in flow, control elements should always be adjusted slowly.

The calibration has been carried out for defined media conditions. Deviations in the density, pressure or temperature of gases, or in the density or viscosity of liquids, result in measurement errors. It is essential to observe the calibration conditions. When ordering, it is therefore essential to provide data on the medium, density and viscosity at the operating temperature and pressure. With gases, it is additionally necessary to specify the exact reference point for the pressure (pressure above atmospheric, or absolute pressure).

Retrofitting of switching contacts is only possible if variable area meters with magnets are used. When using for the first time, move the float completely past the contact to permit polarization.

Classification according to PED 97/23/EC

	Order No. 7ME5815-	Permissible media	Category
DN 15 to DN 80 (G¼ to G2)	xxaxx-xxxx; a ≠ K, R	Gases of fluid group2 and liquids of fluid group1	Article 3.3
≤ DN 25 (G¼ to G1)	xxaxx-xxxx; a = K, R	Gases of fluid group1 and liquids of fluid group1	Article 3.3
> DN 25 (G1¼ to G2)	xxaxx-xxxx; a = K, R	Gases of fluid group1 and liquids of fluid group1	I

Variable area meter F VA Unox

Selection of float

There are three versions of floats:

- Non-guided float
- Guided float
- Viscosity-compensated float.

Use of the viscosity-compensated float is necessary above the following viscosities:

Flow tube	mPa.s (cp)
C 125 to C 500	≥ 3
D 650 to D 3000	≥ 5
E 4000 to F 10000	≥ 8
G 12500 to H 25000	≥ 10

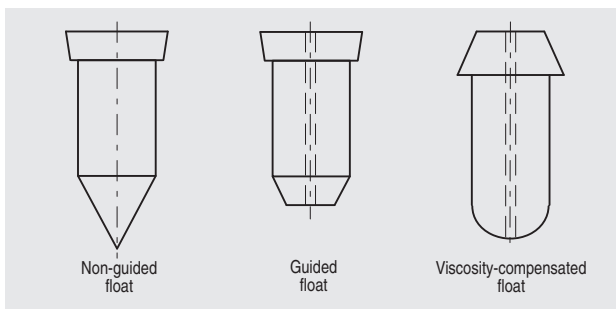

Fig. 2 Float versions

Float guide rod (see also Tables on page 5 and 6)

The float guide rod prevents the float from making contact with the glass flow tube.

The option is recommended to increase the operational safety and to protect against glass breakages in the case of operating conditions such as solenoid valve control. The option is not possible in conjunction with floats with magnets and weighted PVC/ PVDF floats.

Liquids

Standard: flow tubes E 4000 to H 25000

Option: flow tube C 125 and upwards

Gases

Standard: flow tubes D 2500 to H 25000

Option: flow tube C 125 and upwards

Dimensions

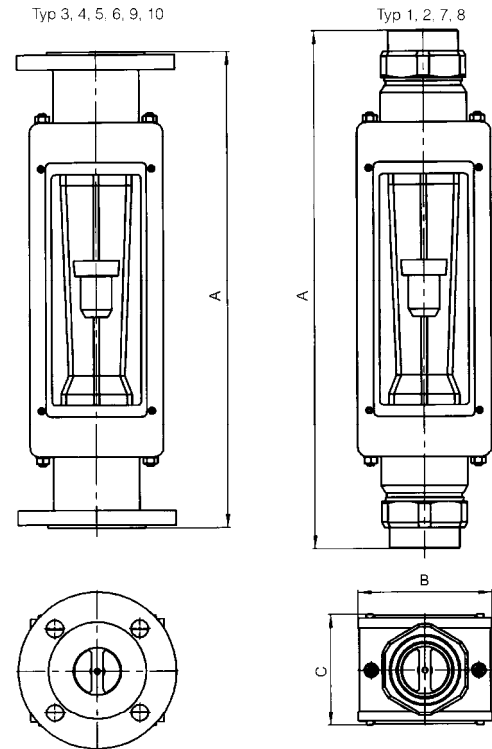

Connection		Flow tube	Dimensions in mm (inch)			
Thread	Flange		A±4 (0,16)	B	C	
G	DN (ANSI)		Typ 1,2,7,8	Typ 3,4,5,6,9,10		
1/2 (3/8, 1/4)	15 (1/2 in)	A 1 to C 500	490 (19,29)	500 (19,68)	84 (3,31)	65 (2,56)
		D 650 to D 1000			100 (3,94)	80 (3,15)
1 (3/4, 1/2)	25 (1 in)	D 1250 to D 3000	500 (19,68)		118 (4,65)	100 (3,94)
1 1/2 (1 1/4)	40 (1 1/2 in)	E 4000 to E 6500	535 (21,06)		138 (5,43)	115 (4,53)
2 (1 1/2, 1 1/4)	50 (2 in)	F 8000 to F 10000	540 (21,26)		142 (5,59)	120 (4,72)
		G 12500 to G 16000			168 (6,61)	150 (5,91)
	80 (3 in)	H 20000 to H 25000			185 (7,28)	170 (6,69)

Fig. 3 Unox, dimensions in mm (inch)

Dimensions: flange according to DIN is always drilled to PN 10

Variable area meter F VA Unox

Technical specification

Application	See at page 1
Mode of operation	See at page 1
Measuring principle	Variable-area flowmeter
Input	
Flow	Vertically upwards
Rated operating conditions	
Temperature limits	
• With float made of stainless steel 1.4305 / 303 or 1.4571 / 316Ti or aluminium	Max. 150 °C / 302 °F
• With float made of PVDF	Max. 100 °C / 212 °F
• With float made of PVC	Max. 50 °C / 122 °F
	Engraved scale required with temp. of medium >90 °C / 194 °F
Medium conditions	
• Accuracy	Class 1,6 (according to VDE/VDI 3513, sheet 2)
• Measuring range	Dependent on flow tube, see Tables on pages 3 and 4
- for liquids	0,1 l/h to 25 m ³ /h / 0,00044 to 110 USgpm
- for gases	1,6 l/h to 400 m ³ /h / 0.009 to 235.4 scfm
	A special scale must be provided for liquids with a density other than 1 kg/l / 62,43 lb/cu.ft and all gases l/h (up to flow tube D2500) m ³ /h (flow tube D3000 and above)
• Dimensions for measured variable	
Permissible operating pressure for flow tube:	
• A 1 to D 3.000	Max. 10 bar / 145 psi
• E 4.000 to F 10.000	Max. 8 bar / 116 psi
• G 12.500 to H 25.000	Max. 5 bar / 73 psi
Design	
Connections	Flanges DIN 15 to DN 80 (DIN 2501) / ½ to 3 inch, optional ANSI 16.5 B, screwed gland G ¼ to G2
Material	
• Flow tube	Borosilicate glass (length 300 mm (11,81 inch))
• Connection	EN-GJL-250 (GG25), optional: stainl. steel mat.No. 1.4571 / 316Ti or GG25, liner with hard rubber or PTFE
• Float	Stainl. steel mat.No. 1.4305 / 303, mat.No.1.4571 / 316Ti, PVC, PVDF, aluminium
• Float guide rod	Stainl. steel mat.No. 1.4571 / 316 Ti as standard for: <ul style="list-style-type: none"> • Flow tubes D 2.500 to H 25.000 for gases • Flow tubes E 4.000 to H 25.000 for liquids As option for flow tube C 125 and above (not together with contacts)
• Gasket	Buna N up to 90 °C/194 °F, Viton up to 150 °C/302 °F, PTFE up to 150 °C/ 302 °F, EPDM up to 150 °C/302 °F
• Limit	Springs made of stainl. steel up to flow tube D3.000, otherwise limit buffer from gasket material
Weight	
• DN 15 (G½)	6 kg (13,23 lb)
• DN 25 (G1)	10 kg (22,05 lb)
• DN 40 (G½)	14 kg (30,86 lb)
• DN 50 (G2)	14 kg (30,86 lb)
• DN 65	26 kg (57,32 lb)
• DN 80	27 kg (59,52 lb)

Technical specification of contacts

Switching principle	Magnet spring contact
Designation	
• Flow tube size C 125 bis H 25000	K 17
• Flow tube size D 650 bis H 25000	K 23
Housing/plug	PP/PA 6
Contact material	Rhodium
Degree of protection	IP65
Ambient temperature	-20 to +80 °C / -4 to +176 °F
Max. switching frequency	5/min
Max. rating	
• K 17	AC 250 V/0,5 A/10 VA DC 250 V/0,5 A/5 W
• K 23	AC 250 V/1 A/150 VA DC 250 V/1 A/100 W
	Rating data apply to resistive loads; a suppressor circuit is required for inductive loads

Contact assembly

The bistable contact assembly K17 consists of a contact spring set sealed in a glass tube filled with protective gas.

Three contacts can be selected:

- K 17 A: contact closes when the limit is fallen below
- K 17 B: contact closes when the limit is exceeded
- K 23: changeover contact.

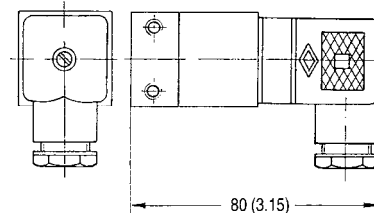

Fig. 4 Contact Kontakt K17, dimensions in mm (inches)

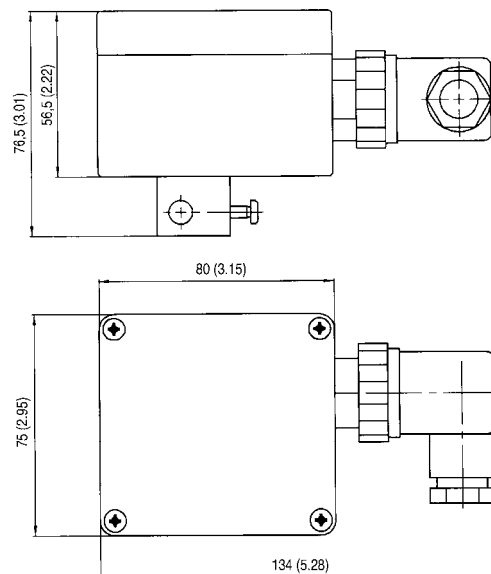

Fig. 5 Changeover contact K23, dimensions in mm (inches)

Variable area meter F VA Unox

Versions

Ten standard versions are defined in the price list using different combinations of fittings, connection materials and floats (the type numbers correspond to the 4th digit in the 2nd block of the Order No.)

Standard designs of the variable area meters (for liquids)

Version	Type 1 (J)	Type 2 (K)	Type 3 (L)	Type 4 (M)	Type 5 (N)	Type 6 (P)	
Measured medium	Liquids						
Connection material	Steel	Mat.No. 1.4571/316 Ti	GG25	Mat.No. 1.4571/316Ti	GG25	GG25	
Liner of fittings				Mat.No. 1.4571/316Ti above DN65	Hard rubber	PTFE	
Connection type	Thread	Thread	Flange	Flange	Flange	Flange	
Float	Standard	Mat.No. 1.4571/1.4305 316Ti/303	Mat.No. 1.4571/316Ti	Mat.No. 1.4571/1.4305316Ti/303	Mat.No. 1.4571/316Ti	Mat.No. 1.4571/316Ti	PVDF weighted ²⁾
	Options	SV, Mat.No. 1.4571/316Ti ¹⁾	SV, Mat.No. 1.4571/316Ti ¹⁾	SV, Mat.No. 1.4571/316Ti ¹⁾	SV, Mat.No. 1.4571/316Ti ¹⁾	PVC, PVDF weighted ²⁾ and SV in Mat.No. 1.4517/316Ti ¹⁾	-
Contact	As option with flow tube C 125 and above only with magnetic float						
Flow tube, size	A to F	X	X	X	X	X	X
	G and H	-	-	X	X	X	X

¹⁾Float SV only viscosity-compensated with flow tube C and above

²⁾Float PVC and PVDF only weighted with flow tube B and above

³⁾Float PVDF only delivered without contact.

Standard designs of the variable area meters (for gases)

Version	Type 7 (Q)	Type 8 (R)	Type 9 (S)	Type 10 (T)
Measured medium	Gases			
Connection material	Steel	Mat.No. 1.4571/316 Ti	GG25	GG25
Liner of fittings	PTFE			
Connection type	Thread	Thread	Flange	Flange
Float	Standard	Aluminium	Aluminium	Aluminium
	Options	PVC or PVDF ³⁾	PVC or PVDF ³⁾	PVC or PVDF ³⁾
Contact	As option with flow tube C 125 and above only with magnetic float			-
Flow tube, size	A to F	X	X	X
	G and H	-	-	X

Variable area meter F VA Unox

Measuring ranges for liquids

Standard measuring range for liquid ($\rho = 1\text{kg/l}$ (62,43) lb/cu.ft, viscosity 1 mPa.s (1cp)) (dynamic range 1:10)

Connection	Flange DN (ANSI)	Flow-tube	Pressure loss	Max. measuring range for the selected floats									
				Up to flow tube B100 mat.No.		Viscosity-compensated, mat.No.		With magnet mat.No.		PVC/PVDF weighted		PVC/PVDF with magnet	
Female thread G			mbar (psi)	1.4305, 1.4571	303/316Ti	1.4571	316Ti	1.4571	316Ti				
				l/h	(Usqpm)	l/h	(Usqpm)	l/h	(Usqpm)	l/h	(Usqpm)	l/h	(Usqpm)
(G1/4), (G3/8), G1/2	15 (1/2")	A 1	10 (0,145)	1	(0,0044)	-	-	-	-	-	-	-	-
		A 3		3	(0,013)	-	-	-	-	-	-	-	-
		A 5		5	(0,022)	-	-	-	-	-	-	-	-
		A 10		10	(0,044)	-	-	-	-	-	-	-	-
		A 25		25	(0,110)	-	-	-	-	-	-	-	-
		B 30		30	(0,132)	-	-	-	-	11	(0,048)	-	-
		B 40		40	(0,176)	-	-	-	-	15	(0,066)	-	-
		B 50		50	(0,22)	-	-	-	-	20	(0,088)	-	-
		B 65		65	(0,29)	-	-	-	-	25	(0,110)	-	-
		B 80		80	(0,35)	-	-	-	-	32	(0,141)	-	-
		B 100	100	(0,44)	-	-	-	-	40	(0,176)	-	-	
		C 125	20 (0,290)	125	(0,55)	100*	(0,44)*	120	(0,53)	65	(0,29)	65	(0,29)
		C 160		160	(0,70)	125*	(0,55)*	150	(0,66)	90	(0,40)	90	(0,40)
		C 200		200	(0,88)	160*	(0,70)*	180	(0,79)	110	(0,48)	110	(0,48)
		C 250		250	(1,10)	200*	(0,88)*	240	(1,06)	140	(0,62)	140	(0,62)
		C 315	40 (0,58)	315	(1,39)	240*	(1,06)*	300	(1,32)	175	(0,77)	175	(0,77)
C 400	400	(1,76)		300*	(1,32)*	360	(1,58)	220	(0,97)	220	(0,97)		
C 500	500	(2,20)		360*	(1,58)*	480	(2,11)	250	(1,10)	250	(1,10)		
D 650	19 (0,28)	650	(2,86)	400*	(1,76)*	600	(2,64)	500	(2,20)	450	(1,98)		
D 800		800	(3,52)	500*	(2,20)*	750	(3,30)	600	(2,64)	550	(2,4)		
D 1000		1000	(4,4)	600*	(2,64)*	950	(4,18)	750	(3,30)	700	(3,1)		
D 1250		1250	(5,5)	750*	(3,30)*	1200	(5,3)	1000	(4,40)	900	(4,0)		
(G1/2), (G3/4), G1	25 (1")	D 1600	24 (0,35)	1600	(7,0)	1000*	(4,40)*	1500	(6,6)	1250	(5,50)	1100	(4,8)
		D 2000		2000	(8,8)	1200*	(5,28)*	1800	(7,9)	1600	(7,0)	1400	(6,2)
		D 2500	33 (0,48)	2500	(11,0)	1400*	(6,16)*	2400	(10,6)	2000	(8,8)	1750	(7,7)
		D 3000		3000	(13,2)	1800*	(7,9)*	2800	(12,3)	2400	(10,6)	2000	(8,8)
(G11/4), G11/2, G2, (G1 1/2), only with flange connection	40 (1 1/2")	E 4000	25 (0,36)	4000*	(17,6)*	2500*	(11,0)*	3800*	(16,7)*	3200	(14,1)	3200	(14,1)
		E 5000		5000*	(22,0)*	3000*	(13,2)*	4800*	(21,1)*	3800	(16,7)	3800	(16,7)
		E 6500		6500*	(28,6)*	4000*	(17,6)*	6400*	(28,2)*	5000	(22,0)	5000	(22,0)
G2, (G1 1/2), only with flange connection	50 (2")	F 8000	34 (0,49)	8000*	(35,2)*	4500*	(19,8)*	7500*	(33,0)*	6400	(28,2)	6400	(28,2)
		F 10000		10000*	(44,0)*	5500*	(24,2)*	9500*	(41,8)*	7500	(33,0)	7500	(33,0)
(G1 1/2), only with flange connection	65 (2 1/2")	G 12500	38 (0,55)	12500*	(55,0)*	7000*	(30,8)*	12000*	(52,8)*	10000	(44,0)	9000	(39,6)
		G 16000		16000*	(70,4)*	9000*	(39,6)*	16000*	(70,4)*	15000	(66,0)	12500	(55,0)
(G1 1/2), only with flange connection	80 (3")	H 20000	38 (0,55)	20000*	(88,0)*	11000*	(48,4)*	18000*	(79,2)*	18000	(79,2)	15000	(66,0)
		H 25000		25000*	(110,1)*	14000*	(61,6)*	24000*	(105,7)*	22000	(96,8)	18000	(79,2)

*Guided float

Non-standard sizes for the connections are listed in square brackets

Variable area meter F VA Unox

Measuring ranges for air

Standard measuring range for air ($p_{abs} = 1,013 \text{ bar (14,69 psi)}$ at $T = 0^\circ\text{C (32}^\circ\text{F)}$, $\rho = 1,293 \text{ kg/m}^3$, $v = 0,181 \text{ mPa.s}$) (dynamic range 1:10)

Connection	Flow-tube	Pressure loss	Max measuring range for the selected floats											
			Aluminium, mat. No. 3.1645		Aluminium, mat. No. 3.1645 with magnet		PVC		PVDF		PVC with magnet			
Female thread G, NPT	Flange DN (ANSI) mm (inch)		mbar	(psi)	(l/h)	(scfm)	(l/h)	(scfm)	(l/h)	(scfm)	(l/h)	(scfm)	(l/h)	(scfm)
(G ¼)	15 (1/2")	A 1	4 (0,058)	16	(0,009)	-	-	10	(0,006)	10	(0,006)	-	-	
(G 3/8)		A 3		50	(0,029)	-	-	25	(0,015)	25	(0,015)	-	-	
G ½		A 5		80	(0,047)	-	-	50	(0,029)	50	(0,029)	-	-	
		A 10		160	(0,094)	-	-	80	(0,047)	80	(0,047)	-	-	
		A 25		400	(0,235)	-	-	250	(0,147)	250	(0,147)	-	-	
		B 30		500	(0,294)	-	-	320	(0,188)	360	(0,212)	-	-	
		B 40		650	(0,383)	-	-	450	(0,265)	500	(0,294)	-	-	
		B 50		800	(0,471)	-	-	550	(0,324)	650	(0,383)	-	-	
		B 65		1100	(0,647)	-	-	750	(0,441)	800	(0,471)	-	-	
		B 80		1400	(0,824)	-	-	900	(0,530)	1000	(0,589)	-	-	
		B 100	1600	(0,942)	-	-	1100	(0,647)	1250	(0,736)	-	-		
		C 125	6,5 (0,094)	2000	(1,18)	2500	(1,47)	1400	(0,824)	1500	(0,883)	2200	(1,29)	
		C 160		3000	(1,77)	3200	(1,88)	1800	(1,06)	2000	(1,18)	3000	(1,77)	
		C 200		3600	(2,12)	4000	(2,35)	2200	(1,29)	2500	(1,47)	3600	(2,12)	
		C 250		4000	(2,35)	5000	(2,94)	2800	(1,65)	3000	(1,77)	4500	(2,65)	
		C 315		15 (0,218)	5000	(2,94)	6400	(3,77)	3400	(2,00)	3600	(2,12)	6000	(3,53)
		C 400	6400		(3,77)	8000	(4,71)	4000	(2,35)	5000	(2,94)	7000	(4,12)	
		C 500	8000*		(4,71)*	-	-	5000*	(2,94)*	5500*	(3,24)*	-	-	
		D 650	7 (0,102)	10000	(5,89)	12000	(7,06)	7000	(4,12)	8000	(4,71)	10000	(5,89)	
	D 800	13000		(7,65)	15000	(8,83)	9000	(5,30)	9000	(5,30)	12000	(7,06)		
	D 1000	16000		(9,42)	20000	(11,77)	11000	(6,47)	12000	(7,06)	16000	(9,42)		
(G ½)	25 (1")	D 1250	9 (0,131)	20000	(11,77)	24000	(14,13)	14000	(8,24)	15000	(8,83)	20000	(11,77)	
(G ¾)		D 1600		28000	(16,48)	32000	(18,83)	18000	(10,59)	20000	(11,77)	25000	(14,71)	
G1		D 2000		36000	(21,19)	40000	(23,54)	22000	(12,95)	25000	(14,71)	32000	(18,83)	
		D 2500	12 (0,174)	40000*	(23,54)*	-	-	28000*	(16,48)*	30000	(17,66)*	-	-	
		D 3000		50000*	(29,43)*	-	-	32000*	(18,83)*	36000	(21,19)*	-	-	
(G1¼)	40 (1 1/2")	E 4000	10 (0,145)	64000*	(37,67)*	75000*	(44,14)*	45000	(26,49)	50000	(29,43)	60000	(35,31)	
G1½		E 5000		80000*	(47,09)*	100000*	(58,86)*	55000	(32,37)	65000	(38,26)	80000	(47,09)	
(G 1½)		E 6500		100000*	(58,86)*	125000*	(73,57)*	75000	(44,14)	80000	(47,09)	100000	(58,86)	
		F 8000		140000*	(82,4)*	150000*	(88,29)*	90000	(52,97)	100000	(58,86)	125000	(73,57)	
only with flange connection	50 (2")	F 10000	13 (0,189)	160000*	(94,17)*	180000*	(105,9)*	120000	(70,63)	125000	(73,57)	160000	(94,17)	
		G 12500		200000*	(117,7)*	220000*	(129,5)*	130000*	(76,52)*	150000*	(88,29)*	175000*	(103,0)*	
	G 16000	280000*	(164,8)*	300000*	(176,6)*	180000*	(105,9)*	200000*	(117,7)*	240000*	(141,3)*			
	80 (3")	H 20000	14 (0,203)	320000*	(188,3)*	360000*	(211,9)*	220000*	(129,5)*	250000*	(147,1)*	300000*	(176,6)*	
H 25000		400000*		(235,4)*	450000*	(264,9)*	280000*	(164,8)*	300000*	(176,6)*	360000*	(211,9)*		

*Guided float

Non-standard sizes for the connections are listed in square brackets

Variable area meter F VA Unox

Selection and ordering data

F VA Unox variable area meter glas flow tube		7ME5815-		- - - - -	
Flow tube size				↑ ↑ ↑ ↑ ↑ see right	
A	1	1A	1		
A	3	2A	1		
A	5	3A	1		
A	10	4A	1		
A	25	5A	1		
B	30	1B	1		
B	40	2B	1		
B	50	3B	1		
B	65	4B	1		
B	80	5B	1		
B	100	6B	1		
C	125	1C	1		
C	160	2C	1		
C	200	3C	1		
C	250	4C	1		
C	315	5C	1		
C	400	6C	1		
C	500	7C	1		
D	650	1D	2		
D	800	2D	2		
D	1000	3D	2		
D	1250	4D	3		
D	1600	5D	3		
D	2000	6D	3		
D	2500	7D	3		
D	3000	8D	3		
E	4000	1E	4		
E	5000	2E	4		
E	6500	3E	4		
F	8000	1F	5		
F	10000	2F	5		
G	12500	1G	6		
G	16000	2G	6		
H	20000	1H	7		
H	25000	2H	7		
Standard versions acc. to table on page 5					
Version					
• Type 1					
Threaded connection: steel					
Float: 1.4305/303, 1.4571/316Ti					
• Type 2					
Threaded connection: steel (c)					
Float: 1.4571, 316Ti					
• Type 3					
Flange connection: GG25					
Float: 1.4305/303, 1.4571,					
• Type 4					
Flange connection: 1.4571/316					
Float: 1.4571/316Ti					
• Type 5					
Flange connection: GG25					
Liner: Hard rubber					
Float: 1.4571/316Ti					
• Type 6					
Flange connection: GG25					
Liner: PTFE					
Float: PVDF weighted					
• Type 7					
Threaded connection: Steel (c)					
Float: aluminium					
• Type 8					
Threaded connection: stainless					
Float: aluminium					
• Type 9					
Flange connection: GG25					
Float: aluminium					
• Type 10					
Flange connection: GG25					
Liner: PTFE					
Float: PVDF					

* Not available for types 1, 2, 7 and 8.

Selection and ordering data

F VA Unox variable area meter glas flow tube		7ME5815-		- - - - -	
Gasket material				↑ ↑ ↑ ↑ ↑ see left	
• Buna N (Standard)				1	
• Viton				4	
• PTFE				5	
• EPDM				8	
Contacts (only with magnetic float)					
• Without contact				0	
• Contact K17/A (closes when limit is fallen below)				1	
• Contact K17/B (opens when limit is fallen below)				2	
• 2 contacts K17/A				3	
• 2 contacts K17/B				4	
• Changeover contact K23				5	
• 1 per contact K17/A and K17/B				6	
Connection size (see page 3)					
• Female thread G1/4, NPT 1/4					B
• Female thread G3/8, NPT 3/8					C
• Female thread G1/2, NPT 1/2					D
• Female thread G3/4, NPT 3/4					E
• Female thread G1, NPT 1					F
• Female thread G1 1/4, NPT 1 1/4					G
• Female thread G1 1/2, NPT 1 1/2					H
• Female thread G2, NPT 2					J
• Flange connection DN 15					M
• Flange connection DN 25					N
• Flange connection DN 40					P
• Flange connection DN 50					Q
• Flange connection DN 65					S
• Flange connection DN 80					R
Connection type					
• Female thread DIN ISO 228					A
• Female thread (NPT)					C
• Flange connection DIN 2501					D
• Flange connection ANSI 16.5 B					E
Float version					
• Standard				0	
• Guided				1	
• Mat.No. 1.4571/316Ti with magnet				2	
• PVC with magnet				3	
• PVC with magnet (only for liquid)				4	
• Viscosity-compensated (SV)				5	
• PVC				6	
• PVDF				7	
• Aluminium with magnet				8	
• Special version (specify in plain t				9	
Further designs					
Please add "-Z" to Order No. And specify Order code(s)					
B06	With calibration certificate				
Y01	Measured medium, always required, specify in plain text: Medium, measuring range, dimension, density, viscosity, operating temperature, operating pressure				
Y02	With engraved scale >90°C (194°F)				
Y04	Silicone-free version				
Y05	Water as measured medium				
	Viscosity: 1mPa.s (cp), Density 1 kg/l (62,43 lb/cu.ft)				
Y99	Special version (specify in plain text)				

Variable area meter

F VA Unox

Selection and ordering data

F VA Unox	7ME5890-	0
Glass flow tube	↑↑↑↑↑	↑↑↑↑↑
Spare parts	↑↑↑↑↑	↑↑↑↑↑
Flow tube		see right
Without flow tube		0A
Size A 1		1A
Size A 3		2A
Size A 5		3A
Size A 10		4A
Size A 25		5A
Size A 35		6A
Size B 30		1B
Size B 40		2B
Size B 50		3B
Size B 65		4B
Size B 80		5B
Size B 100		6B
Size C 125		1C
Size C 160		2C
Size C 200		3C
Size C 250		4C
Size C 315		5C
Size C 400		6C
Size C 500		7C
Size D 650		1D
Size D 800		2D
Size D 1000		3D
Size D 1250		4D
Size D 1600		5D
Size D 2000		6D
Size D 2500		7D
Size D 3000		8D
Size E 4000		1E
Size E 5000		2E
Size E 6500		3E
Size F 8000		1F
Size F 10000		2F
Size G 12500		1G
Size G 16000		2G
Size H 20000		1H
Size H 25000		2H
Float material		A 08
without float		A 08
<u>Flow tube: Size/material</u>		
A / mat.No. 1.4571/316Ti		A 1
A / Aluminium		A 3
A / PVDF, not weighted		A 7
A / PVC, not weighted		A 8
B / mat.No. 1.4571/316Ti		B 1
B / Aluminium		B 3
B / PVC, weighted		B 7
B / PVC, not weighted		B 8
C / mat.No. 1.4305/303		C 1
C / mat.No. 1.4571/316Ti		C 2
C / Aluminium		C 3
C / PVC, weighted		C 7
C / PVC, not weighted		C 8
D / mat.No. 1.4305/303		D 1
D / mat.No. 1.4571/316Ti		D 2
D / Aluminium		D 3
D / PVC, weighted		D 7
D / PVC, not weighted		D 8
E / F / mat.No. 1.4305/303		E 1
E / F / mat.No. 1.4571/316Ti		E 2
E / F / Aluminium		E 3
E / F / PVC, weighted		E 7
E / F / PVC, not weighted		E 8
G / H / mat.No. 1.4571/316Ti		F 2
G / H / Aluminium		F 3
G / H / PVC, weighted		F 4
G / H / PVC, not weighted		F 5

Selection and ordering data

F VA Unox	7ME5890-	0
Glass flow tube	↑↑↑↑↑	↑↑↑↑↑
Spare parts	↑↑↑↑↑	↑↑↑↑↑
Float design		see left
• Standard		0
• With magnet		1
• Guided		2
• With magnet and guided		3
(only for flow tube sizes E, F, G, H)		
• Version without float		8
Gasket material (only together with a flow tube)		
Without gaskets		0A
<u>Flow tube: size/material</u>		
A, B, C / Buna N		1B
D to D1000 / Buna N		3B
D up to D1250 / Buna N		4B
E / Buna N		5B
F / Buna N		6B
G / Buna N		7B
H / Buna N		8B
<u>Flow tube: size/material</u>		
A, B, C / Viton		1D
D up to D1000 / Viton		3D
D for D1250 and above / Viton		4D
E / Viton		5D
F / Viton		6D
G / Viton		7D
H / Viton		8D
Accessories		
Without accessories		A
<u>2 stainless steel limit springs for:</u>		
Flow tube size A, B		B
Flow tube size C		C
Flow tube size D		D
<u>2 stainless steel limits with float guide rod and Buna N limits</u>		
Flow tube size C		H
Flow tube size D		J
Flow tube size E		K
Flow tube size F		L
Flow tube size G		M
Flow tube size H		N
Further designs		
Please add"-Z" to Order No. And specify Order code(s)		
B06	With calibration certificate	
Y01	Measured medium, always required, specify in plain text: Medium, measuring range, dimension, density, viscosity, operating temperature, operating pressure	
Y02	With engraved scale >90°C (194°F)	
Y04	Silicone-free version	
Y05	Water as measured medium	
	Viscosity: 1mPa.s (cp), Density 1 kg/l (62,43 lb/cu.ft)	
Y99	Special version (specify in plain text)	