

# Hot Tap Insertion Vortex

# Model HTIV General Specification

## Product Features

- The same insertion meter can measure Steam, Gases or Liquids.
- Standardize on an insertion bar that can measure line sizes 2" – 48"
- Heavy Duty & Maintenance Free Design
- Hot Tap 1 ½" NPT Connection
- All parts are welded stainless steel construction
- No moving parts
- Sensors never touch process fluid
- No holes to clog
- No pins or screws to corrode and rust
- Can handle process pressure over 1000 psig
- Can handle process temperature up to 450 °F (standard) and 650 °F (high temp)
- Industry standard two wire 4-20 mA output signals



**Accuracy • Reliability • Standardization • Installation**

The **HTIV** vortex sensing element is CNC machined out of one piece of solid stainless steel. The ceramic piezo electric sensors are bonded inside the vortex element which is press fit to the stainless steel insertion bar and completely welded together. There are NO internal o-rings or seals of any kind and absolutely NO leak paths into the sensors or electronics. Our sensors NEVER touch the process fluid giving them an almost unlimited life span.

With over 100 years of combined CNC machining experience our solid stainless steel **HTIV** vortex element has no pins, screws or gaskets of any kind. The bluff body and tail piece are CNC machined from the body of the element. Since there are no holes to clog and no moving parts, there are no mechanical limitations due to frequency or velocities. Our machined elements will never wear or move out of place, giving the same steady frequency from the first day to year thirty.

Each **HTIV** comes with its own seal assembly that rides along the shaft of the insertion bar. This stainless steel seal assembly has a 1 ½" NPT connection for easy connect and disconnect with any valve, thread-o-let or any ANSI class flange. The **HTIV** can be installed or removed during flow with our insertion tool assisting the installer during high pressure applications.

The unique design of the **HTIV** can be used in STEAM, GAS or LIQUID lines. The same **HTIV** design can measure water as low as 1.2 feet per second and natural gas and super heated steam in excess of 250 feet per second.

If for any reason the insertion bar is damaged, it can be easily removed and replaced. The **HTIV** can measure in line sizes 2 inches to 48 inches in diameter making it a good meter to standardize since one spare **HTIV** fits many line sizes and almost all fluid types.

The **HTIV** has no moving or wearing parts making certain that the K Factor, pulses per foot – per second, will not change over time and long term accuracy is always constant. This allows all of our insertion instruments to achieve an accuracy of  $\pm 1\%$  of reading with  $\pm .25\%$  repeatability.



# Application Guide

Model	Liquid	Gas	Steam	Hot Tap	Temperature Range		Maximum Pressure		Line Sizes	
					°F	°C	PSI	Bar	in	mm
HTIV	Yes	Yes	Yes	Yes	-250 to 650	-120 to 345	1000	68.90	2 to 48	50 to 1200

NOTE: The same meter can be used in Steam, Gas and Liquids. The insertion bar and sensors are universal among all process fluid types.

## Performance Specifications

### Accuracy (linear ranges)

#### Liquid.....± 1.0% of flow rate

Test conditions: Water at 65 °F (18.3 °C), 50 psig (3.4 bar)  
with 10 pipe diameters upstream and 5 pipe diameters downstream

#### Gas.....± 1.0% of flow rate

Test conditions: Air at 65 °F (18.3 °C), 25 psig (1.7 bar)  
with 10 pipe diameters upstream and 5 pipe diameters downstream

#### Steam.....± 1.0% of flow rate

Test conditions: Saturated Steam at 125 psig (8.6 bar)  
with 10 pipe diameters upstream and 5 pipe diameters downstream

#### Repeatability.....± .25% of flow rate

#### Flow Rate

Adjustable from:  
1 second  
1 minute  
1 hour  
1 day

#### Response Time

1 – 1000 seconds

#### Analog Output

Calibrated to .001mA of reading

## Operating Specifications

### Linear Range

Reynolds number from 10,000 to 7,000,000

*Measurement Range may vary depending on density*

### Measurable Flow Velocities

Liquid Flow	English	Metric
V <sub>min.</sub>	1.32 ft/s	.402 m/s
V <sub>max.</sub>	32 ft/s	9 m/s
Gas and Steam Flow	English	Metric
V <sub>min.</sub>	$\sqrt[3]{\left(\frac{140}{\rho}\right)}$ ft/s	$\sqrt[3]{\left(\frac{143}{\rho}\right)}$ m/s
V <sub>max.</sub>	300 ft/s	91 m/s
Where:	$\rho$ = density (lb/ft <sup>3</sup> )	$\rho$ = density (kg/m <sup>3</sup> )



## Ambient Temperature Limit

32 to 145 °F (0 to 61 °C)

## Ambient Humidity Limit

5 to 100% relative humidity non-condensing

## Power Requirements

### Standard

Isolated 14 – 36 VDC

### Optional

110/220 VAC

*Note: All power supplies come standard with NEMA 4X explosion proof enclosures and watertight multipole power connectors.*

## Output Signals

### Analog

4 – 20 mA, 2 – wire system, auto digitally adjusted span

### Display

6 Digits of Rate w/ Floating Decimal  
Available in all Engineering Units

8 Digits of Total  
Available in all Engineering Units

### Serial Port

For Reading and Loading Operating Parameters

## Microtel Smart TX (Local & Remote)

### Operator Interface

Continuously displays both rate and total including all engineering units

2 lines, 16 characters each line, alphanumeric, reflective L.C.D. display

Field calibration with local keypad

Electronics are universal among all Nice vortex meter types

### Diagnostics & Setup

Serial communication for computer Interface

Alphanumeric error messages displayed  
For turbulent or erratic flow, flow above or below the calibrated range, and high flow or low flow cut off points

User of factory programmable parameters for sampling time, calibration, filtration, and units displayed through the serial communications port and keypad

Built in non-volatile memory for setup and calibration data, data logging information, as well as other parameters.

Over 20 year retention of flow information.



# Physical Specifications

## Materials

### Wetted Parts of Meter

304L or 316L C&C Machined  
Stainless Steel.

### External Parts

304L or 316L C&C Machined  
Stainless Steel.

### Electrical Enclosure Specifications

Aluminum

NEMA 4X explosion, dust,  
and water proof requirements.

FM Approved  
UL Classified  
CSA Approved  
ATEX for use in;

Class I, Groups B,C & D,  
Class II, Groups E,F & G and  
Class III hazardous locations as  
defined by the National Electrical Codes  
and Canadian Electrical Code.

### Process Connection

HTIV ...1 ½" NPT or Flange ANSI

(ANSI 150, 300, 400, 600, 900, 1500)

*NOTE: Same process connection  
for line sizes 2 – 48"*

### Seal Assembly

Screws down into a 1 ½" NPT connection.  
Slides along shaft of insertion bar for a  
leak free installation.

Seal assembly allows the insertion bar to  
slide into the process. An arrow is CNC  
machined into the top of the insertion bar  
which must point down stream allowing for  
precise vortex shedding and signal  
generation.

Comes standard in 304L Stainless Steel.  
(Optional 316L Stainless Steel)

### Remote Mountable Electronics (Optional)

Available up to 300 ft (90.144m) from meter.  
Uses beldin 24 gage shielded twisted pair.  
Provided with two watertight mutipole power  
plugs.

Includes 383 Aluminum Enclosure.  
Approved for NEMA 4X watertight and  
explosion proof requirements.

## Measurable Flow Rates

Water Minimum and Maximum Flow Rates <sup>1</sup>										
in. (mm)	2 (50)	3 (80)	4 (100)	6 (150)	8 (200)	12 (300)	16 (400)	24 (600)	36 (900)	48 (1200)
gpm	13 315	32 700	51 1210	115 2750	205 4700	460 11,166	725 16,625	1,650 38,500	3,740 88,046	66,50 156,700
m <sup>3</sup> /h	3 70	4.5 160	10 270	19 625	39 1,065	98 2,380	150 3,775	355 8,570	855 20,052	1,520 35,690

1. Standard conditions of 68 °F (20 °C) in schedule 40 pipe



# Measurable Flow Rates

Saturated Steam Minimum and Maximum Flow Rates (lb/hr)										
Pressure <sup>2</sup> (Density) <sup>3</sup>	2"	3"	4"	6"	8"	12"	16"	24"	36"	48"
<b>5</b> (.0486)	55 1025	120 2,250	215 3,875	498 8,800	850 15,200	1,900 34,000	2,989 53,750	6,900 123,000	16,200 284,000	28,800 505,520
<b>50</b> (.1503)	115 3,160	255 7,000	455 12,000	1,050 27,200	1,800 47,000	4,050 106,000	6,500 167,000	14,500 378,000	34,050 880,000	60,609 1,566,400
<b>100</b> (.2577)	170 5,450	385 11,950	670 20,550	1,500 47,010	2,600 81,000	5,900 180,000	9,300 285,000	26,000 807,000	49,000 1,505,000	87,220 2,678,900
<b>150</b> (.3614)	215 7,600	480 16,700	830 29,000	1,900 65,300	3,300 115,000	7,400 253,000	11,700 400,050	26,600 909,000	61,000 2,112,000	108,580 3,759,360
<b>200</b> (.4688)	255 9,850	575 22,000	989 37,400	2,250 85,000	3,925 147,000	8,800 330,000	13,900 518,000	31700 1,180,000	73,000 2,740,000	129,940 4,877,200
<b>300</b> (.6481)	315 13,600	720 30,000	1225 52,000	2,790 118,000	4,900 203,000	10,900 453,400	17,000 716,000	39,300 1,630,000	91,500 3,787,000	162,870 6,740,860
<b>400</b> (.8613)	389 18,100	855 40,000	1,500 68,600	3,400 155,500	5,900 270,000	13,200 603,000	20,900 951,500	47,500 2,165,000	110,000 5,033,000	195,800 8,958,740
<b>500</b> (1.122)	486 22,625	1,069 50,000	1,875 85,750	4,250 194,375	7,375 337,500	16,500 753,750	26,125 1,189,375	59,375 2,706,250	137,500 6,291,250	244,750 11,198,425
<b>1000</b> (2.279)	1,011 47,060	2,223 104,000	3,900 178,360	8,840 404,300	15,340 702,000	34,320 1,567,800	54,340 2,473,900	123,500 5,629,000	291,250 13,085,800	518,425 23,292,724

- 2. psig
- 3. lb/ft<sup>3</sup>

Saturated Steam Minimum and Maximum Flow Rates (kg/hr)										
Pressure <sup>4</sup> (Density) <sup>5</sup>	50mm	80mm	100mm	150mm	200mm	300mm	400mm	600mm	900mm	1200mm
<b>.4</b> (.7779)	26.25 465	58 1020	98 1760	225 4,000	389 6,900	880 15,500	1,355 24,350	3,100 55,300	7,300 130,000	12,994 231,400
<b>3.4</b> (2.372)	55.50 1,450	120 3,110	198 5,350	470 12,150	830 21,050	1,825 47,000	2,900 74,200	6,600 169,000	15,500 392,500	27,590 698,650
<b>6.9</b> (4.127)	80 2,460	165 5,400	300 9,300	690 21,200	1,200 37,000	2,700 82,000	4,200 129,100	9,600 294,000	22,400 683,000	39,872 1,215,740
<b>11</b> (6.125)	98 3,640	225 8,020	390 13,800	898 31,350	1,500 54,225	3,400 121,300	5,500 192,000	12,600 436,000	29,000 1,013,300	51,620 1,803,674
<b>13.8</b> (7.508)	115 4,460	255 9,850	440 17,000	998 38,400	1700 66,500	4,000 149,000	6,300 235,000	14,400 534,500	33,500 1,245,000	59,630 2,216,100
<b>20.7</b> (10.38)	145 6,175	315 13,600	555 23,400	1275 53,100	2200 92,000	4,900 206,000	7,800 325,000	17,800 740,000	41,000 1,717,250	72,980 3,056,705
<b>27</b> (13.79)	175 8,200	390 18,100	675 31,100	1,500 70,550	2,600 122,200	6,000 273,300	9,400 431,500	21,500 981,500	50,000 2,283,000	89,000 4,063,740
<b>34.5</b> (17.969)	220 10,260	484 22,675	850 38,888	1,927 88,151	3,344 15,3061	7,482 341,836	11,848 539,399	26,927 1,227,324	62,358 2,853,174	110,997 5,078,650
<b>69</b> (36.5)	458 21,342	1,008 47,165	1,768 80,888	4,009 183,356	6,956 318,367	15,564 711,020	2,4643 1,121,950	5,6009 2,552,834	129,705 5,934,603	230,875 10,563,59

- 4. bar
- 3. kg/m<sup>3</sup>



# Measurable Flow Rates

Natural Gas Minimum and Maximum Flow Rates (SCFM) <sup>1</sup>										
Pressure <sup>2</sup> (Density) <sup>3</sup>	2"	3"	4"	6"	8"	12"	16"	24"	36"	48"
<b>0</b> <b>(.0330)</b>	22.25 345	45 760	83 1,310	190 3,005	326 5,200	745 11,500	1,150 18,150	2,600 41,300	6,200 96,000	11,036 170,880
<b>50</b> <b>(.1451)</b>	58 1,520	125 3,340	220 5,750	505 13,100	885 22,600	1,989 50,600	3,000 80,000	7,200 182,000	16,750 422,100	29,815 751,338
<b>100</b> <b>(.2573)</b>	80 2,700	185 6,000	325 10,200	755 23,200	1,300 40,100	2,900 90,000	4,600 141,500	10,500 322,000	24,500 748,500	43,610 1,332,330
<b>150</b> <b>(.3695)</b>	98 3,860	240 8,500	420 14,700	955 33,250	1,600 58,000	3,700 129,000	5,900 204,000	13,400 462,100	31,000 1,075,000	55,180 1,913,500
<b>200</b> <b>(.4816)</b>	126 5,050	285 11,100	498 19,100	1,100 43,300	1,989 75,000	4,400 168,000	7,000 265,000	16,000 602,500	37,000 1,401,000	65,860 2,493,780
<b>300</b> <b>(.7060)</b>	165 7,400	375 16,250	645 28,000	1,400 63,500	2,500 110,000	5,700 246,000	9,050 388,100	20,700 883,000	48,200 2,053,100	85,796 3,654,518
<b>400</b> <b>(.9303)</b>	198 9,750	445 21,400	775 37,000	1,750 84,000	3,055 145,000	6,900 324,000	10,925 512,000	24,900 1,164,000	58,000 2,706,000	103,240 4,816,680
<b>500</b> <b>(1.155)</b>	235 12,100	525 26,600	898 45,800	1,996 104,000	3,550 180,000	7,998 402,100	12,600 634,800	28,790 1,444,000	66,900 3,358,000	119,082 5,977,240
<b>1000</b> <b>(2.276)</b>	360 23,800	815 52,500	1,400 90,200	3,210 205,000	5,625 355,000	12,600 793,000	19,900 1,252,000	45,300 2,847,000	105,250 6,620,000	187,345 11,783,60

1. Standard conditions of 68 °F (20 °C) in schedule 40 pipe
2. psig
3. lb/ft<sup>3</sup>

Natural Gas Minimum and Maximum Flow Rates (SCMM) <sup>4</sup>										
Pressure <sup>5</sup> (Density) <sup>6</sup>	50mm	80mm	100mm	150mm	200mm	300mm	400mm	600mm	900mm	1200mm
<b>0</b> <b>(.5281)</b>	.630 9.75	1.40 21.50	4.02 37	5.40 84	9.40 146	21.15 326	33.40 514	76 1,170	177 2,720	315 4,842
<b>3.4</b> <b>(2.300)</b>	1.65 42.40	3.70 93.55	6.40 161	14.55 366	25.20 633	56.50 1,416	89.20 2,235	203 5,085	471 11,826	838 21,050
<b>6.9</b> <b>(4.124)</b>	2.50 76.20	5.50 168	9.45 289	21.55 656	37.30 1,135	83.40 2,540	131.50 4,008	298 9,118	695 21,205	1,237 37,745
<b>11</b> <b>(6.260)</b>	3.30 116	7.25 255	12.50 439	28.40 995	49 1,725	110 3,855	174 6,085	395 13,845	920 32,190	1,638 57,298
<b>13.8</b> <b>(7.719)</b>	3.80 143	8.30 314	14.40 541	32.70 1,227	56.60 2,124	126.50 4,752	200 7,505	455 17,068	1,055 39,700	1,878 70,666
<b>20.7</b> <b>(11.31)</b>	4.80 209	10.80 461	18.60 793	42.20 1,800	73.10 3,113	163 6,966	255 11,000	587 25,020	1,365 58,180	2,430 103,560
<b>27.6</b> <b>(14.91)</b>	5.80 275.50	13 607	22.30 1,044	50.75 2,370	87.90 4,105	196 9,180	310 14,500	705 33,000	1,640 76,667	2,919 136,467
<b>34.5</b> <b>(18.51)</b>	6.78 342	15 753	25.80 1,296	58.60 2,945	101 5,092	227 11,393	358 17,988	815 40,950	1,890 95,155	3,364 169,376
<b>69</b> <b>(36.48)</b>	10.70 675	23.55 1,485	40.60 2,555	92.25 5,800	159 10,040	357 22,465	564 35,465	1,280 80,675	2,980 187,600	5,304 333,928

4. Standard conditions of 68 °F (20 °C) in schedule 40 pipe
5. bar
6. kg/m<sup>3</sup>



# Measurable Flow Rates

Air Minimum and Maximum Flow Rates (SCFM)										
Pressure <sup>2</sup> (Density) <sup>3</sup>	2"	3"	4"	6"	8"	12"	16"	24"	36"	48"
<b>0</b> <b>(0.0752)</b>	17 360	35.70 760	60 1,320	146 3,012	250 5,230	560 11,500	880 18,150	2,043 41,250	4,651 95,902	8,279 170,706
<b>50</b> <b>(0.3312)</b>	45 1,525	95 3,350	170 5,750	389 13,050	675 22,600	1,520 50,650	2,389 80,090	5,400 182,000	12,500 425,000	22,250 756,500
<b>100</b> <b>(0.5871)</b>	65 2,700	145 6,010	240 10,200	575 23,250	998 40,100	2,250 90,098	3,500 142,000	8,020 322,000	18,500 750,000	32,930 1,335,000
<b>150</b> <b>(0.8430)</b>	85 3,860	185 8,500	320 14,650	730 33,250	1,250 57,500	2,850 129,000	4,500 203,250	10,200 463,000	23,750 1,075,000	42,275 1,913,500
<b>200</b> <b>(1.0998)</b>	98 5,050	220 11,120	375 19,100	875 43,300	1,505 75,050	3,398 170,000	5,350 265,000	12,200 603,000	28,400 1,400,700	50,552 2,493,246
<b>300</b> <b>(1.611)</b>	130 7,400	280 16,200	475 27,900	1,130 63,500	1,950 11,020	4,375 246,000	6,925 388,125	15,700 883,000	37,000 2,054,000	65,860 3,656,120
<b>400</b> <b>(2.123)</b>	150 9,750	340 21,400	590 37,000	1,330 83,650	2,325 145,000	5,250 324,000	8,300 512,000	18,900 1,165,000	44,000 2,705,000	78,320 4,814,900
<b>500</b> <b>(2.635)</b>	180 12,000	398 26,600	690 46,000	1,525 104,000	2,700 180,000	6,000 402,100	9,600 635,000	21,000 1,445,000	50,900 3,360,000	90,602 5,980,800
<b>1000</b> <b>(5.194)</b>	280 23,800	625 52,400	1,090 90,200	2,450 205,000	4,200 355,000	9,500 793,000	15,000 1,252,000	42,000 3,546,000	80,000 6,620,000	142,400 11,783,600

1. Standard conditions of 68 °F (20 °C) in schedule 40 pipe
2. psig
3. lb/ft<sup>3</sup>

Air Minimum and Maximum Flow Rates (SCMM)										
Pressure <sup>5</sup> (Density) <sup>6</sup>	50mm	80mm	100mm	150mm	200mm	300mm	400mm	600mm	900mm	1200mm
<b>0</b> <b>(1.205)</b>	.480 9.75	1.06 21.5	1.80 37	4.15 84	7.10 145.5	19.40 393	25.40 514	57.80 1170	134 2,720	239 4,842
<b>3.4</b> <b>(5.248)</b>	1.28 42.50	2.80 94	4.80 161	11 366	19.20 633	42.90 1420	67.50 2235	154 5,100	358 11,830	637 21,057
<b>6.9</b> <b>(9.409)</b>	1.90 76.20	4.10 168	7.20 289	16.30 656	28.30 1135	63 2540	100 4010	225 9120	528 21,203	940 37,741
<b>11</b> <b>(14.28)</b>	2.50 116	5.50 255	9.50 439	21.60 995	37.40 1,725	83.75 3,855	130 6,085	300 13,850	695 32,200	1,237 57,316
<b>13.8</b> <b>(17.61)</b>	2.80 143	6.30 314	10.90 541	24.75 1,227	43 2,125	96 4,755	150 7510	345 17,100	804 40,000	1,431 71,200
<b>20.7</b> <b>(25.82)</b>	3.70 210	8.20 461	14.15 795	32 1,800	55.50 3113	120 7,000	195 11,000	445 25,025	1,025 58,200	1,825 103,596
<b>27.6</b> <b>(34.02)</b>	4.40 280	9.80 610	17 1050	38.50 2370	66 4,110	150 9200	235 14,5000	535 33,000	1,240 76,670	2,207 136,473
<b>34.5</b> <b>(42.22)</b>	5.10 342	11.40 755	19.60 1,300	44.50 2,950	77 5,100	170 11,400	270 18,000	620 41,000	1,440 95,200	2,563 169,456
<b>69</b> <b>(83.24)</b>	8.1 670	17.90 1,500	30.50 2,555	70 5,800	120 10,040	270 22,500	425 35,500	970 81,000	2,250 188,000	4,005 334,640

4. Standard conditions of 68 °F (20 °C) in schedule 40 pipe
5. bar
6. kg/m<sup>3</sup>



# Straight Run Piping Requirements

Straight Run Piping Requirements	Upstream	Downstream
One 90° elbow before the meter	10 D	5 D
Two 90° elbows before the meter	15 D	5 D
Two 90° elbows out of plane before the meter	30 D	5 D
Reduction before meter	10 D	5 D
Regulator or Valve partially closed before meter	30 D	5 D
Tee Connection before meter	30 D	5 D

*D* is equal to the internal diameter of the pipe. If there is not sufficient straight run of pipe a straightening plate or our Flanged Vortex Plate Flow Meter can be used to reduce the above lengths. Consult your local representative or factory regarding your application.

## Other Installation Considerations

### Mounting Position

The HTIV can be installed in almost any orientation around the pipe. Vertically, horizontally or angled pipe sections are a good spot to install the HTIV. The mounting assembly will insure that the meter is attached perpendicular to the axis of the pipe. The HTIV should not be installed “upside-down”. For liquid applications, the fluid must completely fill the pipe

### Site Selection

The flow measurement location should be selected to minimize turbulence and swirl. The more laminar the flow profile the better the site location. The extent of the flow turbulence depends on what type of piping is upstream and downstream from the meter. (Please see straight run piping requirements above) Valves, elbows, regulators, pumps, tee connections, and other piping components may add disturbances to the flow.



# Dimensions and Weights

## Hot Tap Insertion Vortex - HTIV

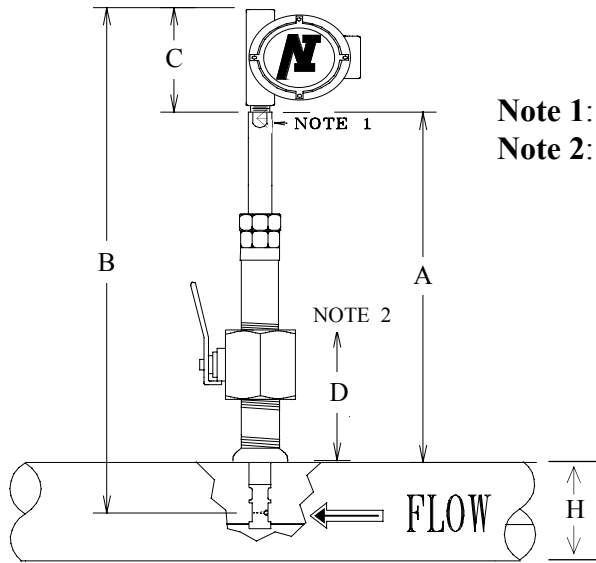

**Note 1:** Alignment arrow must point downstream

**Note 2:** Ball Valve or Gate Valve can be used for valve assembly.

All valves must use a **1 1/2" NPT Connection**.

All valves must be **1 1/2" fully ported**.

All valve assemblies should not exceed D

Not shown with remote electronics

DRAWN BY: T.B.	 <b>TITLE:</b> HTIV
DESIGN ENG	
APPROVED BY	
REVISION NO. : 1	
DATE: 2/7/97	DRAWING NO. MI-2200-02

## Dimension Tables

Model	Connection	H		A		B		C		D (should not exceed)	
		in.	mm	in.	mm	in.	mm	in.	mm	in.	mm
HTIV	1 1/2" NPT	2	50	27.75	693	36	908	7	176	10	252
HTIV	1 1/2" NPT	4	100	26.75	668	36	908	7	176	10	252
HTIV	1 1/2" NPT	6	150	25.75	643	36	908	7	176	10	252
HTIV	1 1/2" NPT	8	200	24.75	618	36	908	7	176	10	252
HTIV	1 1/2" NPT	10	250	23.75	593	36	908	7	176	10	252
HTIV	1 1/2" NPT	12	300	22.75	568	36	908	7	176	10	252
HTIV	1 1/2" NPT	14	350	21.75	543	36	908	7	176	10	252
HTIV	1 1/2" NPT	16	400	20.75	518	36	908	7	176	10	252
HTIV	1 1/2" NPT	18	450	19.75	493	36	908	7	176	10	252
HTIV	1 1/2" NPT	20	500	18.75	468	36	908	7	176	10	252
HTIV	1 1/2" NPT	22	550	18.75	468	36	908	7	176	10	252
HTIV	1 1/2" NPT	24	600	18.75	468	36	908	7	176	10	252
HTIV	1 1/2" NPT	26	650	18.75	468	36	908	7	176	10	252
HTIV	1 1/2" NPT	28	700	18.75	468	36	908	7	176	10	252
HTIV	1 1/2" NPT	30	750	18.75	468	36	908	7	176	10	252
HTIV	1 1/2" NPT	32	800	18.75	468	36	908	7	176	10	252
HTIV	1 1/2" NPT	34	850	18.75	468	36	908	7	176	10	252
HTIV	1 1/2" NPT	36	900	18.75	468	36	908	7	176	10	252
HTIV	1 1/2" NPT	38	950	18.75	468	36	908	7	176	10	252
HTIV	1 1/2" NPT	40	1000	18.75	468	36	908	7	176	10	252
HTIV	1 1/2" NPT	42	1050	18.75	468	36	908	7	176	10	252
HTIV	1 1/2" NPT	44	1100	18.75	468	36	908	7	176	10	252
HTIV	1 1/2" NPT	46	1150	18.75	468	36	908	7	176	10	252
HTIV	1 1/2" NPT	48	1200	18.75	468	36	908	7	176	10	252



## HTIV Insertion Tool (The Gold Standard)



Our insertion tool is specially designed to eliminate the weight, bulkiness and equipment malfunction that occurs when insertion tools are permanently connected to the instrument and exposed to the harsh elements of the plant or mother nature. Our insertion tool can be used for installation under extreme pressures and makes it easy for the installer to adjust and fine tune their flow instrumentation. Once the installation is complete the installer can quickly remove the tool and store it to a location away from the harsh environment of the plant or the outdoors. (This tool is offered as an option)

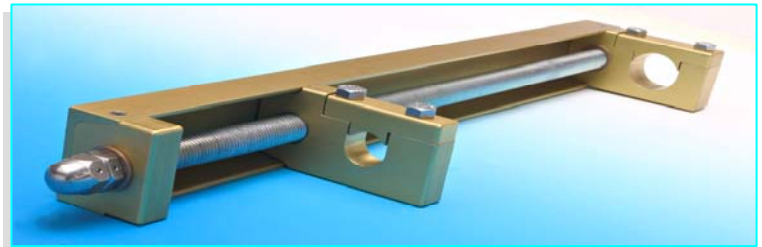

### Tool Dimensions

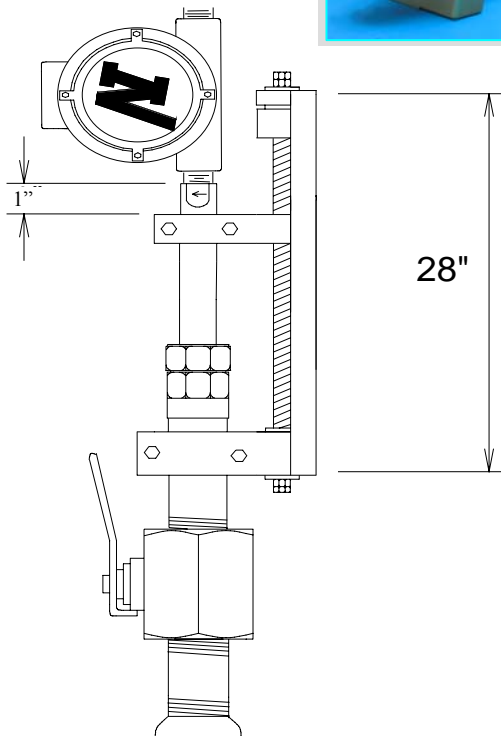

### Specifications

#### Mechanical

Aluminum and Galvanized steel  
Corrosion Resistant Anodized Aluminum

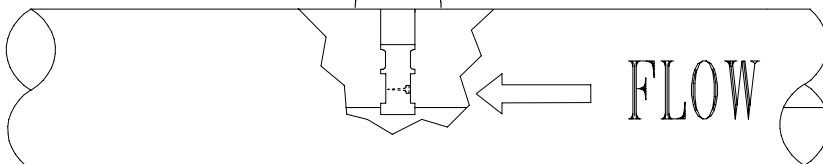

## Multi Pole Power Plug



Our weather proof multi pole connector virtually eliminates wiring errors in the field. Simply plug the connector into the top of the NEMA 4 enclosure and screw it down for a dust free and water tight connection. This design saves the customer time and money because our electronics package never comes out of the enclosure. No internal wiring is required and no connecting of hard to reach terminal blocks. This design also allows for a conduit connection to be screwed over the power plug for power plant and explosion proof requirements. Simply plug and play!

## Dimensions

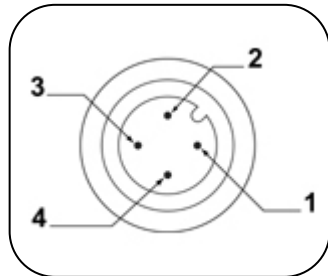
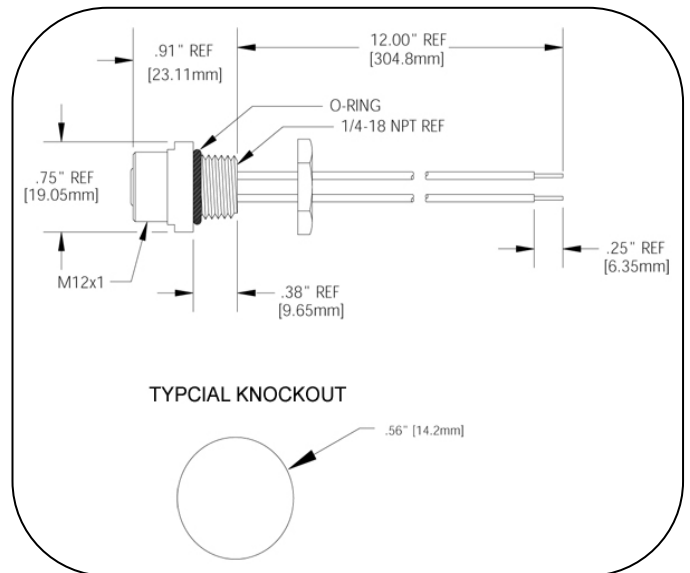
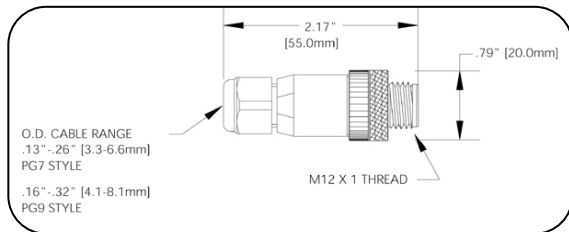

- 1 = Ground
- 2 = none
- 3 = Negative
- 4 = Positive

Note: All plug wiring is completed and checked at factory

## Specifications

Mechanical
Contact Carrier - Polyurethane (PUR)
Pin Contact - Copper Alloy
Contact Plating - Gold over nickel
Body - Polyamide
Grommet - Nitrile
Termination - Screw
Conductor size - #26AWG to #18AWG
Cable Range - .13" - .26" (3.3mm - 6.6mm)
O-ring - Viton
Coupling nut - Nickel Plated Brass

Environmental
Protection - IP68, NEMA 6P
Ambient Operating Temperature - -25C to 85C

Electrical
Voltage Rating - 250V AC/DC
Amperage - 4A

Certifications
UL - UL Classified, File #E152210
CSA - cCSAus, LR6837





