

Electromagnetic flow Sensor *mag-flux F5*



Fig. 1 electromagnetic flow sensor *mag-flux F5*

Application

Electromagnetic flowmeters are suitable for measuring the flow of almost all electrically conducting liquids, as well as sludges, pastes and slurries.

A prerequisite is that the medium must have a certain minimum conductivity. The temperature, pressure, viscosity and density have no influence on the result.

This special design of an electromagnetic flowmeter (MID) is particularly suitable for measuring the flow of extremely small quantities and especially for use with proportioning and batching systems. In conjunction with the transmitters InterMag 2/TransMag 2, complex tasks can be solved using the integral software for batching applications. Typical applications can be found in the food industry, the dosing of chemicals in photographic systems, and the dosing of medicines in medical fields.

When using the alternating field technique with the transmitter TransMag 2, even very small flows can be exactly measured as a result of the larger magnetic field and the zero stability.

The flow sensors *mag-flux F5* are used mainly in the following industries:

- Water and waste water plants
- Chemical and pharmaceutical industry
- Food- and beverage industry
- Mining, cement and mineral materials
- Pulp- and paper industry
- Steel industry
- Power generation and distribution.

The flow sensor are combined with the transmitters InterMag 2/TransMag 2 and are only available as remote versions.

Special features

- Metering tube made from high corrosion- and temperature resistant zirconium oxide
- Metering tube inner diameter 2 mm (0,078") and above
- smallest measuring ranges:
 - 0 to 5 l/h (0 to 0,022 USgpm) with constant field
 - 0 to 3 l/h (0 to 0,0132 USgpm) with alternating field
- very low minimum conductivity:
 - 10 µS/cm with constant field
 - 0,1 µS/cm with alternating field
- robust and interference-free as a result of closed steel housing
- different process connections and materials
 - Thread: DIN, NPT, BSP
 - Flange: DIN, ANSI, JIS
 - Clamp
 - DIN 11851
 - and more upon request
- different process connection materials
 - Mat. No. 1.4571
 - Hastelloy C4 W. Nr. 2.4610
 - PVDF with earthing ring made from Hastelloy C4 mat. No. 2.4610
 - Titanium
 - and more upon request

Note of application

- The operator of these measuring instruments is responsible for suitability, proper use and corrosion resistance of the used materials with regard to the measuring material. It must be ensured that the materials selected for the meter parts in contact with the medium are suitable for the used process media.
- Before replacing the measuring tubes, check that the meter is free of hazardous media and is not pressurized.
- The unit may only be used within the pressure and voltage limits specified on the rating plate.
- The flowmeter complies with the requirements of the Pressure Equipment Directive 97/23/EC, article 3, paragraph 3. The most hazardous permissible media are the fluids defined in group 1.
- Provide a touch guard for surface temperatures of > 70°C. This touch guard must be designed in a way that the max. allowable ambient temperature on the unit is not exceeded.
- The sensor must not be affected by external loads.
- The units are designed for predominantly recumbent load.

Electromagnetic flow Sensor *mag-flux* F5

Installation

The measuring principle is generally independent of the flow profile. Ideally, the device should be installed in a pipeline, which has sufficient straight tubing before and after the measuring point. In general, an inlet path of min. 5 x dia. and an outflow zone of min. 2-3 x dia. is required.

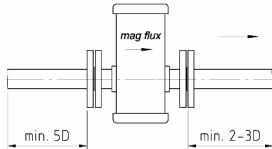

Provided that constant turbulence does not enter the area in which the measurement takes place (e.g. after elbows, during tangential feeds or if the valve in front of the sensor is partially open). In such cases measures to normalize the flow profile are necessary. Suitable measures in this respect are:

- increasing the inlet and outlet zones
- using flow conditioners
- reducing the inner diameter of the pipe

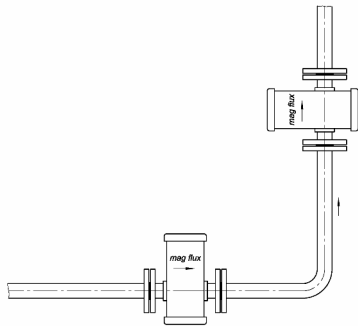

Fig. 2 Installation in horizontal and vertical pipelines

Installation may be horizontal or vertical (Fig. 2) but it must be ensured that the axes of the electrodes run horizontally (the direction arrow marks the electrode axes) to avoid measuring errors due to deposits or air bubbles on the electrodes.

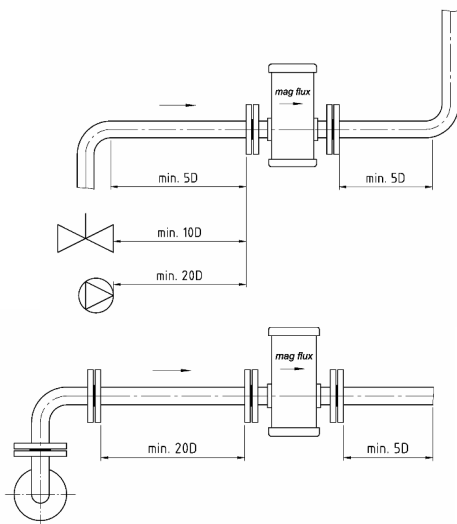

Fig. 3 Installation between pipe elbows, valves and pumps

The inlet and outlet zones must be kept straight (Fig. 3).

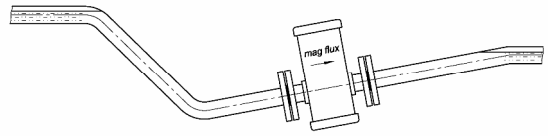

Fig. 4 Installation in a constantly filled pipe

The flow measuring device must be installed so that the measuring pipe cannot run empty and is always filled with medium. The sensor must be installed in a culvert in the case of an unfilled pipe or only a free level line (outlet).

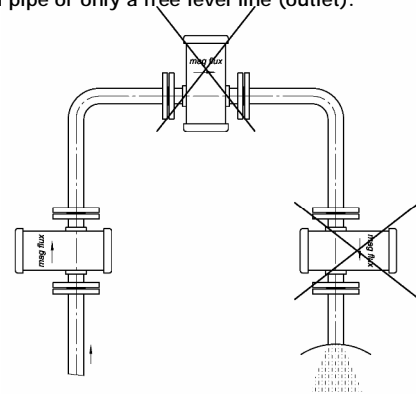

Fig. 5 Installation in pipes without emptying

The sensor should not be installed in pipe sections with a free pipe outlet which could run empty (e.g. downpipes). When installing in a downpipe make sure that the pipe is always filled 100% with the medium.

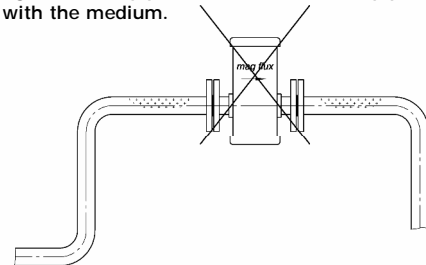

Fig. 6 Installation at the highest point

Avoid installation at the highest point of the pipe due to accumulation of gas.

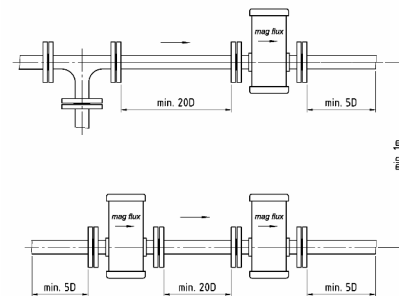

Fig. 7 Installation of several sensors, either in series or in parallel

If several sensors are series connected, the distance between the individual sensors must be at least equal to the length of one sensor. If two or more sensors are to be connected in parallel, the distance must be at least 1 m.

Electromagnetic flow Sensor *mag-flux* F5

Dimensions

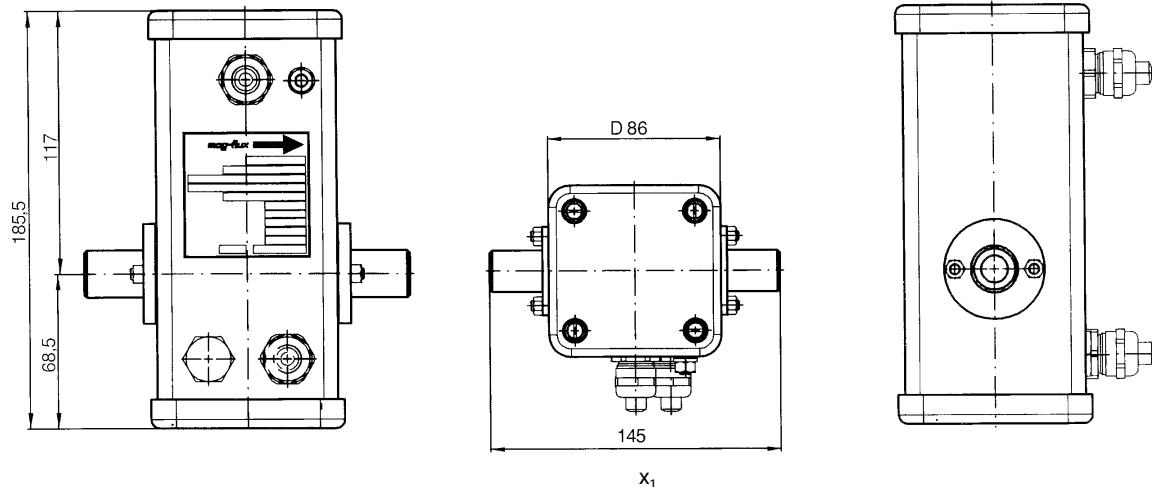

Fig. 2 Electromagnetic flow Sensor *mag-flux* F5 (without wall mount), dimensions in mm

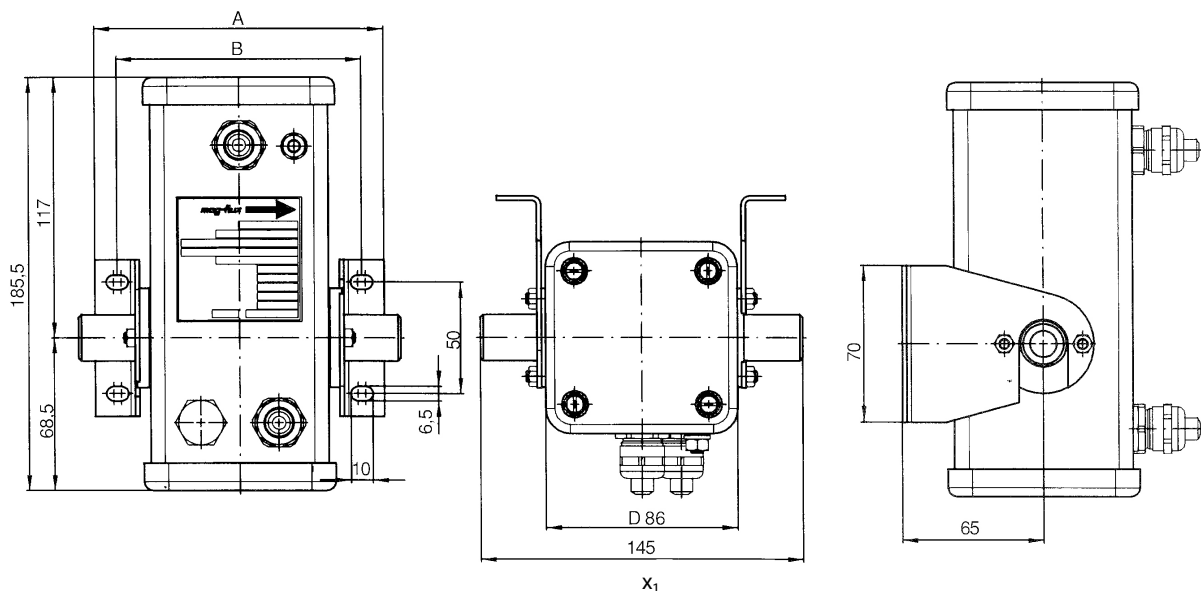

Fig. 3 Electromagnetic flow Sensor *mag-flux* F5 (with wall mount), dimensions in mm

Connection material	Dimension A	Dimension B
Metal	133	132
Plastic	140	120

X₁: if flange connection material is PVDF, installation dimension is 160mm!

Electromagnetic flow Sensor

mag-flux F5

Technical Data

Application field	see page 1			
Measuring principle	pulsed constant field (DC) pulsed alternating field (AC)			
Inlet				
Nominal diameter metering tube	Measuring range			
	Constant field	Alternating field		
2 mm (0,078")	5 - 110 l/h	3 - 110 l/h		
4 mm (0,156")	25 - 450 l/h	15 - 450 l/h		
8 mm (0,312")	100 - 1800 l/h	60 - 1800 l/h		
12 mm (0,47")	200 - 4000 l/h	120 - 4000 l/h		
Measuring accuracy				
Error of measurement	± 0,5 % of measured value 0,25 m/s to 10 m/s			
Repeat accuracy	± 0,15 % of measured value 0,25 m/s to 10 m/s			
Operational conditions				
Mounting position	vertical or horizontal			
Max. operating temperature	150°C / 302°F			
Pressure limits	25 bar/ 362,5 psi higher upon request			
Pressure/temperature limits with PVDF connections (DIN 8062)	Temperature		Max. pressure	
	°C	°F		Bar
	0 - 50	32 - 122	10	145
	60	140	8,5	123
	70	158	7,5	109
	80	176	6,5	94
	90	194	5,5	80
	100	212	4,5	65
110	230	3,8	55	
120	248	3,0	44	
Protection class	IP 67/IP 68			
Minimum conductivity				
• with constant field	> 10 µS/cm			
• with alternating field	> 0,1 µS/cm			
Specifications				
Design	Fully-welded steel fitting with cover made of aluminium			
Weight	approx. 3 kg			
Cable inlet				
• with constant field	2 x M 16 x 1,5 / 2 x ½" NPT			
• with alternating field	3 x M 16 x 1,5 / 3 x ½" NPT			
Material				
• Metering tube	Zirconium oxide			
• Sensor housing	Steel			
• Process connection	Stainless Steel, Hastelloy, PVDF			
Electrodes				
• Material	Platinum 99,9%, sintered			
• Design	Flat electrode			

Ordering data

Electromagnetic flow Sensor

mag-flux F5

MAG561	-	0	0	-	0	0
Measuring principle						
• alternating field						3
• constant field						4
Nominal diameter of metering tube						
• 2 mm						D
• 4 mm						E
• 8 mm						F
• 12 mm						G
Process connection						
• G 1/2, mat.No. 1.4571						A
• G 1/2, HC4 (mat.No. 2.4610)						B
• G 1/2, PVDF with HC4- earthing rings (mat.No. 2.4610)						C
• G 1/2, Titanium						S
• NPT 1/2", mat.No. 1.4571						D
• NPT 1/2", HC4 (mat.No. 2.4610)						E
• NPT 1/2", PVDF with HC4- earthing rings (mat.No. 2.4610)						F
• DN 15 PN 25 DIN 2501, mat.No. 1.4571						H
• DN 15 PN 25 DIN 2501, HC4 (mat.No. 2.4610)						J
• DN 15 PN 25 DIN 2501, PVDF with HC4- earthing rings (mat.No. 2.4610)						K
• 1/2" Tri-Clamp, mat.No. 1.4571						L
• 1" Tri-Clamp, mat.No. 1.4571						N
• 1/2" ANSI B16.5 150 RF, mat.No. 1.4571						Q
• 1/2" ANSI B16.5 150 RF, PVDF with HC4- earthing rings (mat.No. 2.4610)						T
• other connections/ materials						Z
Gasket material						
• EPDM						2
• Kalrez						3
Wall mount						
• without						0
• with						1
Screwed gland						
• M16 x 1,5						C
• NPT 1/2"						B
Degree of protection						
• IP 67 / NEMA 5						B
• IP 68 / NEMA 6 mit 5m firmly connected cable						C
• IP 68 / NEMA 6 mit 10m firmly connected cable						D
Further designs						
• Measuring range < 10 l/h						A10
• TAG plate inscription in english						B11
• with 3-point calibration certificate						B06
• with 6-point calibration certificate						B07
• Silicone-free materials						Y04
• TAG plate stainless steel						Y17