



## High Accuracy/General-purpose/PD Flowmeter

# ULTRA OVAL

METER SIZE: 39, 41, 45, 50, 52, 53, 55, 56, 57

GENERAL SPECIFICATION  
GS.No.GBU005E-10

### ■ GENERAL

Our workhorse PD flowmeter series is redesigned in this ULTRA OVAL with the most advanced multi-function electronic register (ULTRA register) capable of indicating the instantaneous flowrate and total flow on an easy-to-read LCD and of providing the pulse and analog output. Significantly improved performance along with compact and lightweight design are among the many benefits it offers.

### ■ FEATURES

- Flow range expanded by 10 to 90% (over the previously offered OVAL meters of the same sizes).
- Absence of mechanical reduction gear train combined with special carbon bearings contributes to low pressure loss and long life.
- Thanks to pocketless design, the process fluid is virtually free from stagnation in the measuring chamber-beneficial to a broad range of fluids, particularly chemicals and foods.
- Microprocessor-based ULTRA register indicates variables-total flow, both resettable and cumulative, instantaneous flowrate, selectable with mode select switch, plus alarm (low battery alarm) on the LCD.
- Output signal is available in two channels simultaneously in the form of total flow (4/20mA DC factored or unfactored current pulses) and instantaneous flowrate signal (4 to 20mA DC analog).
- A complete series of explosionproof models also available.
- We also manufacture models approved for applicable high-pressure gas control law.



Meter sizes 39, 41, 45



Meter sizes 55, 56



Meter sizes 50, 52, 53



Meter size 57

### ■ GENERAL SPECIFICATIONS

#### ● Meter Body

Item		Description								
Meter size		39	41	45	50	52	53	55	56	57
Nominal size		10mm			20mm	25mm		40mm	50mm	
Flange rating	1 group	JIS 10K RF, ASME/JPI 150 RF								
	3 group	JIS 16, 20, 30K RF, ASME/JPI 300 RF, DIN 10, 16, 20, 25								
Flow range		See flow range tables (page 3).								
Operating temperature range	Standard	-10 to +120°C (※1)								
	Low	—————			-60 to +60°C					
	High	—————			120 to 200°C	120 to 260°C				
	Jacketed	—————			120 to 260°C					
Linearity		±0.35% or ±0.15%								
Repeatability		±0.05% or ±0.02%								
Materials	Body	SCS14 or ▲SCS16								
	Rear cover	SUS316 or ▲SUS316L								
	Rotors	39:Special carbon only, 41 to 57: SUS316 or ▲SUS316L								
	Bearings	39:Special carbon only, 41 to 57: Special carbon or ceramics (※2)								
	Shafts	SUS316 or ▲SUS316L								
Jacketed	Connection	—————			Rc <sup>1</sup> / <sub>2</sub>		Rc <sup>3</sup> / <sub>4</sub>			
	Max. operating press.	—————			0.98MPa					
Flow direction		Right → left (standard), left → right, bottom → top, top → bottom								

※1 : Only the standard models are applicable for ATEX and FM explosionproof.

※ : ▲ Special

※2 : With ceramics bearings, the max. allowable temperature is 60°C. (For information, consult the factory.)

#### ● Flange Rating and Max. Operating Pressure (MPa)

Flange group	Temp.	JIS 10K RF	ASME/JPI 150 RF	JIS 20K RF	JIS 30K RF	ASME/JPI 300 RF
1	Max. 120°C	1.18	1.51	—	—	—
	Max. 200°C	1.18	1.25	—	—	—
	Max. 350°C	—	—	—	—	—
3	Max. 120°C	—	—	2.45	2.94	2.94
	Max. 200°C	—	—	1.7	1.7	1.7
	Max. 350°C	—	—	1.5	1.5	1.5

Applies to body material code C. For body material code E, consult the factory.

## OVAL Corporation

<http://www.oval.co.jp>

Head Office (Tokyo): Phone. 81-3-3360-5121. Fax. 81-3-3365-8605  
Beijing Office: Phone. 86-10-5867-4711. Fax. 86-10-5867-4713  
Overseas Branch Offices: Seoul, Singapore and Taipei

● Register Specifications

Item			Description				
<b>Meter size</b>			※39	41	※45	50, 52, ※53	55, 56, ※57
<b>Local display (LCD) ※1</b>	<b>Cumulative totalizing counter</b>		0.1 mL (std.)	0.001L (std.)	0.001L (std.)	0.01L (std.)	0.1 L (std.)
	<b>Reset counter, 7digits</b>	<b>C mode</b>	1 mL, 0.01L	0.01L, 0.1L	0.01L, 0.1L	0.1L, 1L	1L, 0.01m <sup>3</sup>
	<b>Instantaneous flow rate (5 digits)</b>	<b>b1 mode</b>	1 mL/h (std.)	0.01 L/h (std.)	0.1 L/h (std.)	1 L/h (std.)	1 L/h (std.)
<b>b2 mode</b>		0.01 mL/min (std.)	0.0001 L/min (std.)	0.001 L/min (std.)	0.01 L/min (std.)		
<b>Output signal</b>	— <b>None</b>		Local LCD only				
	<b>Current</b>	<b>Analog</b>		4 to 20 mADC Refer to diagram, page 6.			
		<b>Pulse</b> (※4,5)	<b>Type</b>	Scaled or unscaled: 0/1=4/20 mADC			
			<b>Pulse width</b>	Scaled: 1ms (std.), 50 ms      Unscaled: 2ms			
			<b>Unit of scaled pulse</b>	Same as of LCD counter (※1)			
	<b>Open collector</b>	<b>Pulse</b> (※4,5)	<b>Type</b>	Scaled or unscaled: NPN transistor output: Max. impressed voltage 30 VDC allowable current: 50 mA, transistor on voltage: 1.5VDC and below			
			<b>Pulse width</b>	Scaled: 1ms (std.), 50 ms      Unscaled: 2ms			
			<b>Unit of scaled pulse</b>	Same as of LCD counter (※1)			
	<b>Voltage</b>	<b>Pulse</b> (※4,5)	<b>Type</b>	Scaled or unscaled: [0]1 VDC Max. [1]7 VDC Min.			
			<b>Pulse width</b>	Scaled: 1ms (std.), 50 ms      Unscaled: 2ms			
<b>Unit of scaled pulse</b>			Same as of LCD counter (※1)				
<b>Power supply</b>	<b>Without output signal</b>		Installed lithium battery      Life: 8 years				
	<b>With output signal</b>		External power source: 12 to 45 VDC (analog or current pulse) 12 to 24 VDC (open collector pulse or voltage pulse) 12 to 45 VDC (combination analog and current pulse) Current consumption: Max. 30 mADC Refer to diagram in page 6. (※2)				
<b>Transmission cable</b>			Capture cable w/external shield (VCTF 1.25 mm <sup>2</sup> , finished O. D. 8.5 to 12mm) (※3)				
<b>Transmission length</b>			Max.1 km				
<b>Transmission lines</b>	<b>2-wire system</b>		Analog or current pulse				
	<b>3-wire system</b>		Open collector or voltage pulse				
	<b>4-wire system</b>		Analog + current pulse				
<b>Operating temperature range</b>			-10 to +60°C (Without dew condensation)				
<b>Explosionproof configuration</b>			Select either one from following two ① Non-explosionproof type      ④ ATEX II 2G Exd II BT4 ② TIIS Exd II BT4 / Exi II BT4, Exia II BT3 (※6)      ⑤ FM Class I, Division I / Group C, D T4 ③ NEPSI Exd II BT4 / Exi II BT4, Exia II BT3 (※6)      AEx / Exd II BT4				
<b>Applicable EU directive</b>			EMC 2004 / 108 / EC ATEX 94 / 9 / EC (※7) PED 97 / 23 / EC (※8)				
<b>Applicable EN standard</b>			EMC EN55011 : 1998 / A1 : 1999 Group 1, Class B      EN61000-6-2 : 1999 ATEX EN60079-0 : 2006, EN60079-1 : 2007				
<b>Degree of Protection for enclosure</b>			IP66 (Dust-tight/Watertight Type) -IEC/EN60529 : 1991+A1 : 2000, JIS C 0920				
<b>Material for housing</b>			Aluminum die casting				
<b>Finish</b>			Munsell No. 2.5PB5/8 (baked melamine)				

- ※1 : If factored pulse units other than above are required, consult the factory.
- ※2 : Battery powered register features a local indicator alone; output signal is not available.
- ※3 : For use of output type in hazardous locations, use cables heat resistant to 75°C or higher.  
Do not fail to use pressuretight packings furnished as standard accessories.
- ※4 : Under certain circumstances, the max. flowrate may have limitations if the minimum factored pulse unit is chosen and the pulse width exceeds 1 msec. If this problem arises, consult the factory.
- ※5 : With factored pulse unit indicated by an asterisk ※, pulse width other than 1 ms is NOT selectable.
- ※6 : Code 6 shows explosionproof configuration of ULTRA OVAL register with batch control function.
- ※7 : Details as 94/9/EC compliant explosionproof equipment
- ※8 : Details as 97/23/EC compliant pressure equipment

Applicable hazardous area	Zone 1 and Zone 2
---------------------------	-------------------

Type of Machinery	Pressure machinery
Kind of the fluid	Liquid
Fluid group	1 and 2
DN (mm) Nominal size	10mm to 50mm
Max. operating pressure	2.94MPa (120°C)
Category	Para. 3, Sec. 3 of 97/23EC Directive

■ NOMINAL METER FACTORS

Meter size	Nominal meter factors mL/P	Max. frequency Hz	Max. flowrate m <sup>3</sup> /h	Pulse P/rev.
39	0.09838	33.9	0.012	2
41	0.4896	34.0	0.06	2
45	1.2339	94.6	0.42	4
50	4.968 [4.968]	111.8 [111.8]	2	4 [4]
52	9.664 [9.664]	109.2 [109.2]	3.8	4 [4]
53	17.513 [17.513]	101.5 [101.5]	6.4	4 [4]
55	23.07 [34.60]	168.6 [112.4]	14	6 [4]
56	37.33 [74.66]	178.6 [89.3]	24	8 [4]
57	98.04 [196.08]	124.7 [62.3]	44	8 [4]

※ : [ ] is for Low/High temperatures and it is a value with a jacket.

**FLOW RANGES**

**● Meter sizes: 39 to 45**

Linearity: ±0.35%

Operating temp. range: -10 to +120°C

Unit in L/h

Viscosity Meter size	Less than 0.3mPa-s	0.3mPa-s to 0.8mPa-s	0.8mPa-s to 2mPa-s	2mPa-s to 5mPa-s	5mPa-s to *200mPa-s
39	2 to 12	1.4 to 12	0.7 to 12	0.35 to 12	0.2 to 12
41	18 to 60	12 to 60	4 to 60	2.5 to 60	1 to 60
45	50 to 420	35 to 420	15 to 420	10 to 420	5 to 420

\*Only model 45 can handle up to 1000mPa-s

●The standard accuracy for model 39 is ±0.35%. Consult the factory for ±0.2% accuracy model.

Linearity: ±0.15% (Option)

Operating temp. range: -10 to +120°C

Unit in L/h

Viscosity Meter size	Less than 0.3mPa-s	0.3mPa-s to 0.8mPa-s	0.8mPa-s to 2mPa-s	2mPa-s to 5mPa-s	5mPa-s to *200mPa-s
39	3 to 12	2 to 12	1 to 12	0.5 to 12	0.3 to 12
41	27 to 60	18 to 60	6 to 60	3.7 to 60	1.5 to 60
45	75 to 420	52 to 420	22 to 420	15 to 420	7.5 to 420

**● Meter sizes: 50 to 57**

1. Linearity: ±0.35%

Operating temp. range: -10 to +120°C (std.)

Unit in m³/h

Viscosity Meter size	Less than 0.3mPa-s	0.3mPa-s to 0.8mPa-s	0.8mPa-s to 2mPa-s	2mPa-s to 5mPa-s	5mPa-s to 1000mPa-s
50	0.3 to 1.6	0.15 to 1.6	0.1 to 1.6	0.05 to 2	0.03 to 2
52	0.7 to 3	0.4 to 3	0.3 to 3	0.15 to 3.8	0.08 to 3.8
53	1.1 to 5	0.7 to 5	0.55 to 5	0.28 to 6.4	0.15 to 6.4
55	1.8 to 11	1.2 to 11	1 to 11	0.4 to 14	0.26 to 14
56	3.5 to 20	2.5 to 20	2 to 20	0.9 to 24	0.6 to 24
57	8 to 37	5 to 37	4 to 37	2 to 44	1.2 to 44

2. Linearity: ±0.35%

Operating temp. range: 120 to 200°C

Unit in m³/h

Viscosity Meter size	Less than 0.3mPa-s	0.3mPa-s to 0.8mPa-s	0.8mPa-s to 2mPa-s	2mPa-s to 5mPa-s	5mPa-s to 1000mPa-s
50	0.6 to 1.4	0.3 to 1.4	0.2 to 1.4	0.09 to 1.8	0.05 to 1.8
52	1 to 2.7	0.8 to 2.7	0.5 to 2.7	0.23 to 3.4	0.15 to 3.8
53	2 to 4.5	1.4 to 4.5	0.9 to 4.5	0.35 to 5.7	0.28 to 6.4
55	3.6 to 9	2.4 to 9	1.5 to 9	0.6 to 12	0.4 to 14
56	7.5 to 18	5 to 18	3 to 18	1.4 to 21	0.9 to 24
57	15 to 33	10 to 33	6 to 33	3 to 39	2 to 44

3. Linearity: ±0.35%

Operating temp. range: 200 to 260°C

Unit in m³/h

Viscosity Meter size	0.3mPa-s to 0.8mPa-s	0.8mPa-s to 2mPa-s	2mPa-s to 5mPa-s	5mPa-s to 1000mPa-s
52	1 to 2.7	0.6 to 2.7	0.3 to 3.4	0.16 to 3.8
53	2 to 4.5	1.2 to 4.5	0.6 to 5.7	0.3 to 6.4
55	3.6 to 9	2 to 9	0.8 to 12	0.55 to 14
56	7.5 to 18	4 to 18	1.8 to 21	1.2 to 24
57	15 to 33	8 to 33	4 to 39	2.5 to 44

Note: 1. For measurement of high viscosity fluids (above 1000mPa-s), consult the factory.

2. For flow range of meters for low temperature service (-60 to +60°C) refer to Table 1 or 4.

3. For standard flowmeters (-10 to +60°C) refer to Table 1 or 4.

4. For flow range of meters compatible with thermal shock (-10 to +120°C), refer to Table 2 or 5. (Thermal shock means sharp fluid temperature changes at a rate in excess of 3°C /min. or staircase changes in excess of 30°C between steps.)

**● For flow range with “water,” select by temperature and viscosity brackets from the table below.**

Temperature range	Viscosity range
Max. 30°C	0.8 to 2.0 mPa-s
30 to 80°C	0.3 to 0.8 mPa-s
80 to 120°C	Less than 0.3 mPa-s

4. Linearity: ±0.15% (Option)

Operating temp. range: -10 to +120°C

Unit in m³/h

Viscosity Meter size	Less than 0.3mPa-s	0.3mPa-s to 0.8mPa-s	0.8mPa-s to 2mPa-s	2mPa-s to 5mPa-s	5mPa-s to 1000mPa-s
50	0.5 to 1.6	0.3 to 1.6	0.15 to 1.6	0.08 to 2	0.05 to 2
52	1 to 3	0.7 to 3	0.5 to 3	0.25 to 3.8	0.15 to 3.8
53	1.6 to 5	1.1 to 5	0.75 to 5	0.4 to 6.4	0.22 to 6.4

Operating temp. range: -10 to +60°C

Unit in m³/h

Viscosity Meter size	Less than 0.3mPa-s	0.3mPa-s to 0.8mPa-s	0.8mPa-s to 2mPa-s	2mPa-s to 5mPa-s	5mPa-s to 1000mPa-s
55	2.7 to 11	1.8 to 11	1.5 to 11	0.6 to 14	0.4 to 14
56	5.2 to 20	0.5 to 20	3 to 20	1.4 to 24	0.9 to 24
57	12 to 37	8 to 37	6 to 37	3 to 44	2 to 44

Operating temp. range: 60 to 120°C

Unit in m³/h

Viscosity Meter size	Less than 0.3mPa-s	0.3mPa-s to 0.8mPa-s	0.8mPa-s to 2mPa-s	2mPa-s to 5mPa-s	5mPa-s to 1000mPa-s
55	4 to 11	2.7 to 11	2.2 to 11	0.9 to 14	0.6 to 14
56	8 to 2	5.2 to 20	4.5 to 20	2.1 to 24	1.3 to 24
57	18 to 37	12 to 37	9 to 37	4.5 to 44	3 to 44

5. Linearity: ±0.15% (Option)

Operating temp. range: 120 to 200°C

Unit in m³/h

Viscosity Meter size	0.3mPa-s to 0.8mPa-s	0.8mPa-s to 2mPa-s	2mPa-s to 5mPa-s	5mPa-s to 1000mPa-s
50	0.45 to 1.4	0.3 to 1.4	0.15 to 1.8	0.08 to 1.8
52	1.5 to 2.7	0.9 to 2.7	0.55 to 3.4	0.33 to 3.8
53	2.4 to 4.5	1.5 to 4.5	0.9 to 5.7	0.49 to 6.4
55	4 to 9	2.7 to 9	1.3 to 12	0.9 to 14
56	8 to 18	5.2 to 18	3.1 to 21	1.9 to 24
57	18 to 33	12 to 33	6.7 to 39	7.5 to 44

6. Linearity: ±0.15% (Option)

Operating temp. range: 200 to 260°C

Unit in m³/h

Viscosity Meter size	0.8mPa-s to 2mPa-s	2mPa-s to 5mPa-s	5mPa-s to 1000mPa-s
52	1.5 to 2.7	0.9 to 3.4	0.49 to 3.8
53	2.4 to 4.5	1.3 to 5.7	0.73 to 6.4
55	4 to 9	1.9 to 12	1.3 to 14
56	8 to 18	4.6 to 21	2.8 to 24
57	18 to 33	10 to 39	6.7 to 44

**METER ERRORS AND PRESSURE LOSSES**

● Meter sizes: 39, 41, 45

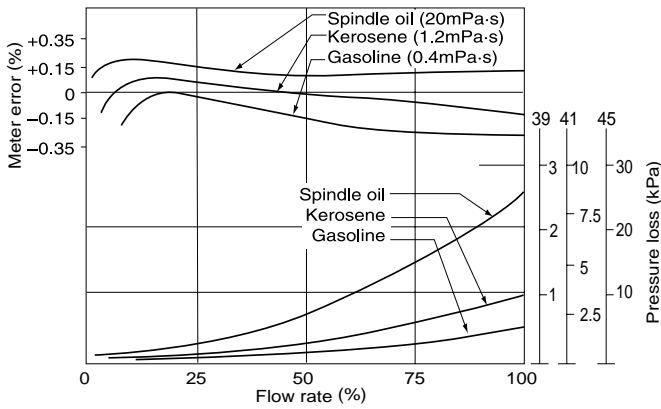

● Meter sizes: 50, 52, 53

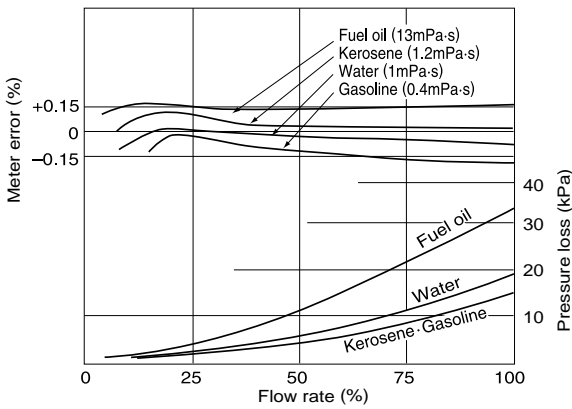

● Meter size: 55

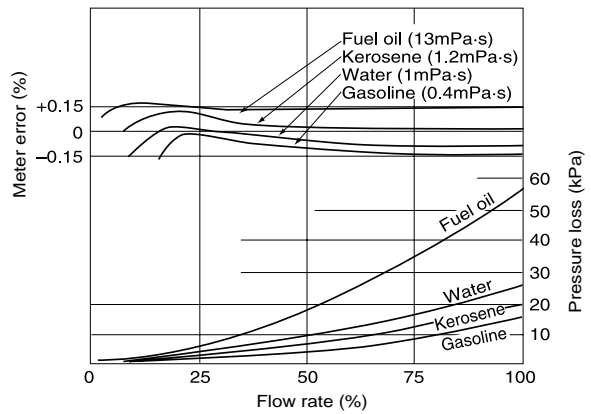

● Meter size: 56

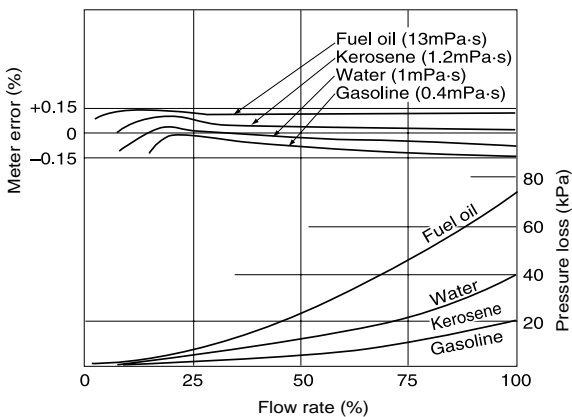

● Meter size: 57

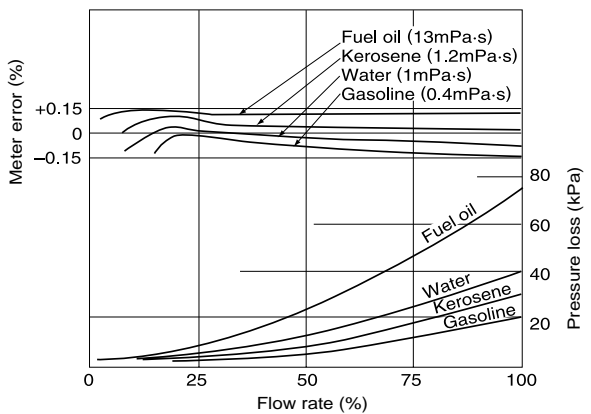

NOTE: 100% flowrate shows the maximum flowrate at individual viscosity.

**HOOKUP WITH RECEIVING INSTRUMENTS**

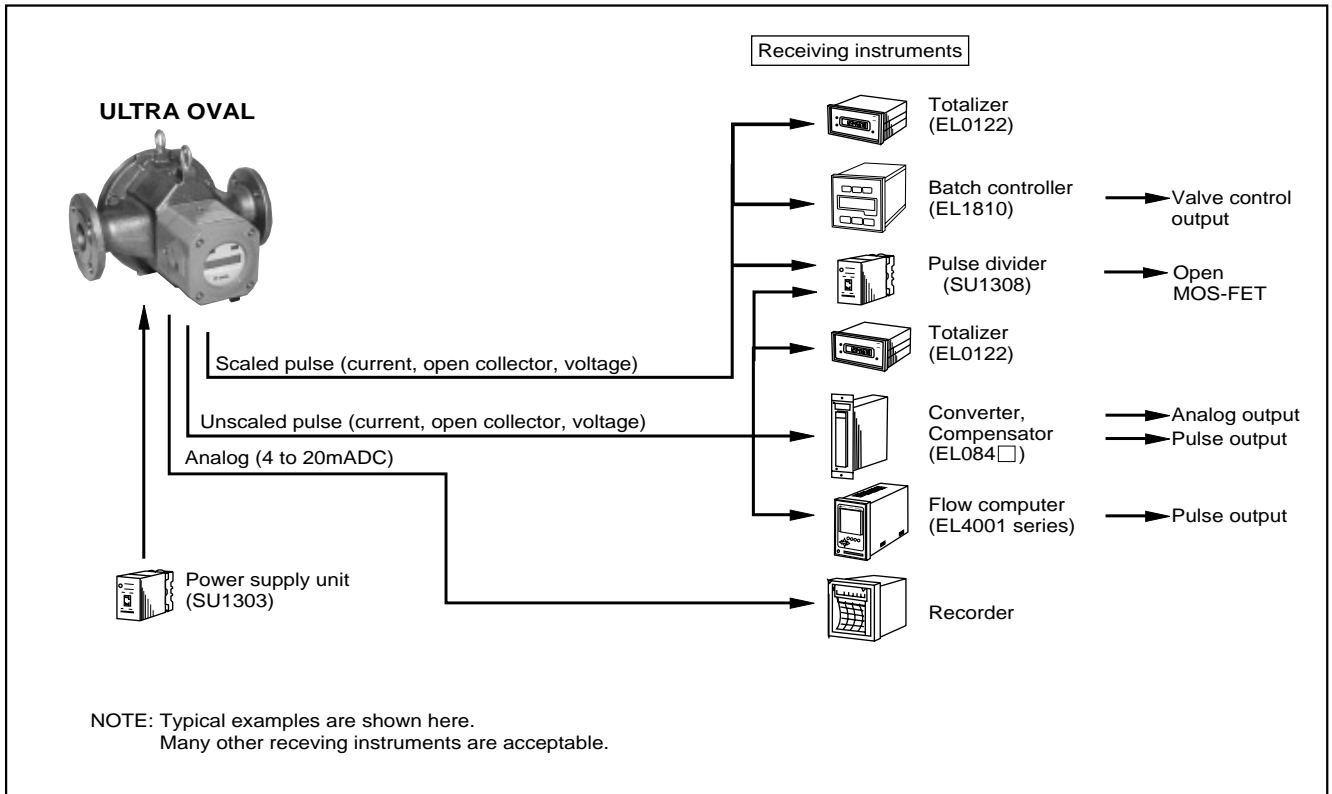

**WIRING CONNECTIONS**

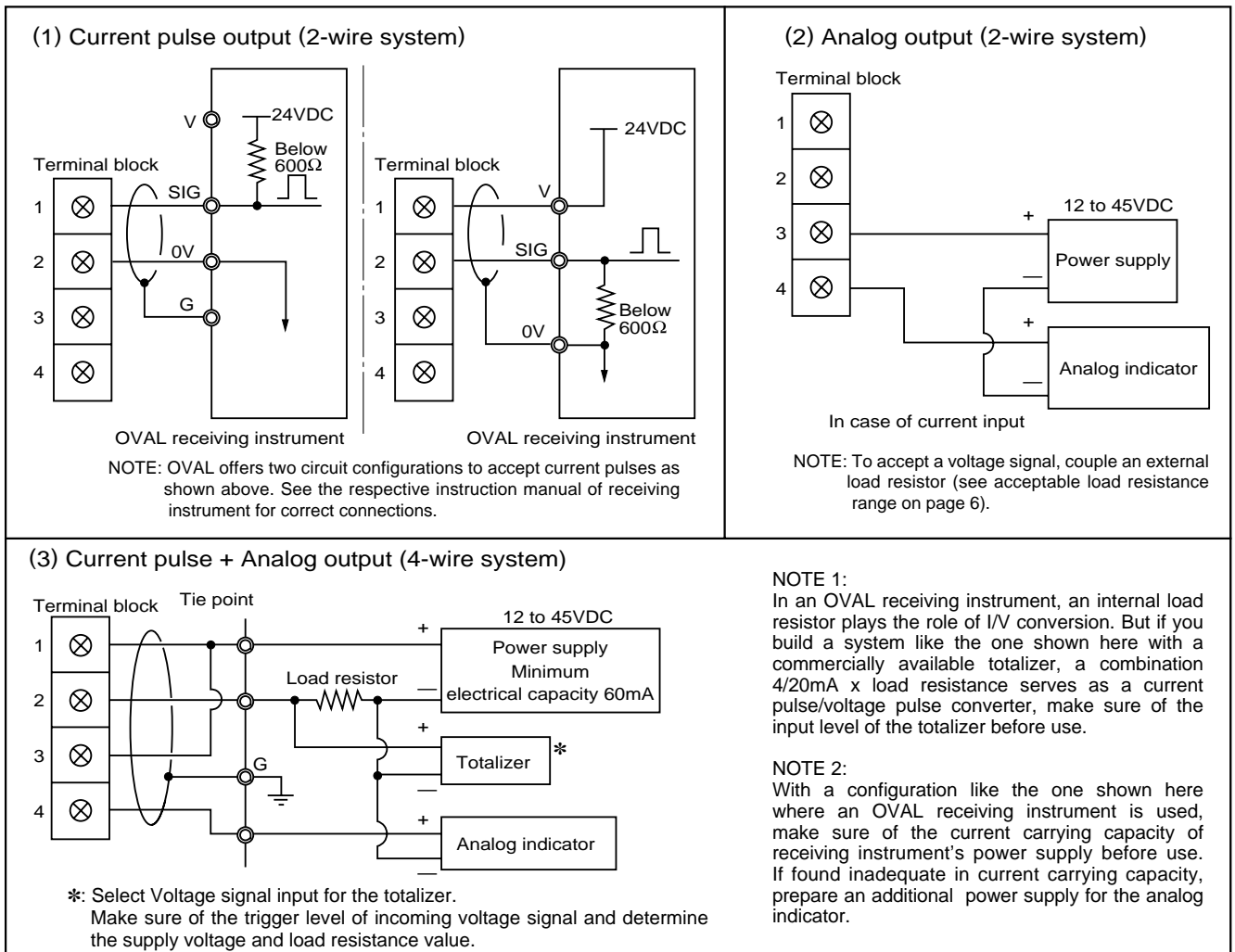

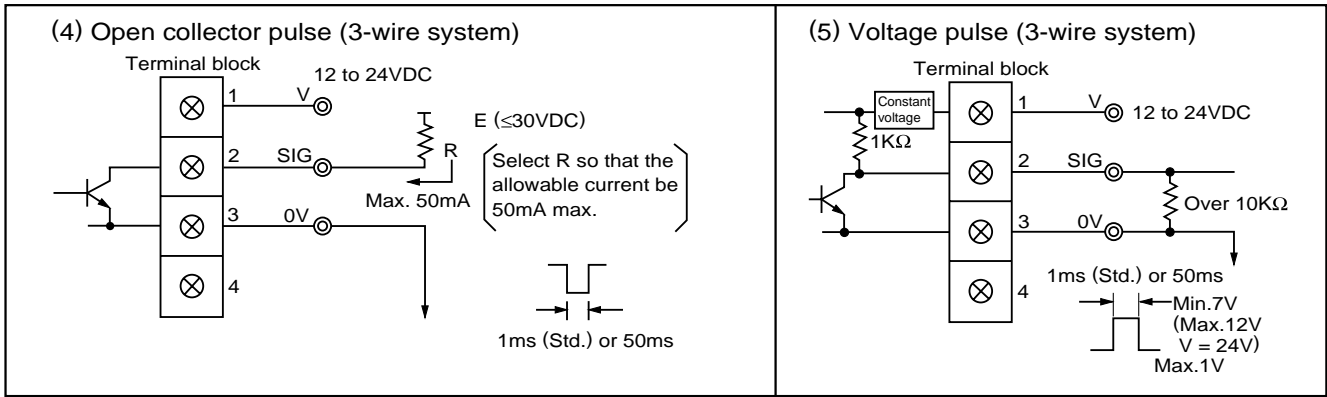

**● Range of Load Resistance (for current pulse and analog output)**

This instrument uses a two-wire transmission line for analog and pulse signals, so the line serves for both power supply and signal. A DC power supply is required for transmission loop. When connecting a meter to the loop, ensure that the meter and the load resistance of cable conductor is within the operating limits shown in the figure at right.

Standard: Power supply voltage = 24VDC  
Load resistance = 250Ω

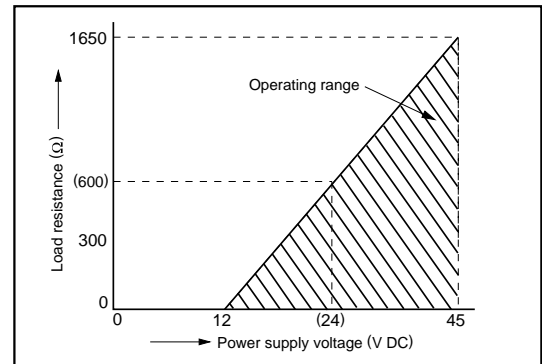

**■ PRODUCT CODE EXPLANATION (Meter sizes 39, 41, 45)**

Item	Code No.												Description
	①	②	③	④	⑤	⑥	⑦	⑧	⑨	⑩	⑪	⑫	
Type	L	U	S										ULTRA OVAL, standard version (-10 to +120°C)
Meter size			3	9									Nominal size 10mm
			4	1									Nominal size 10mm
			4	5									Nominal size 10mm
Body material			C										SCS14
			E										SUSF316 [Special]
Flange rating			1										JIS 10K RF, ASME/JPI 150 RF
			3										JIS 16 to 30K RF, ASME/JPI 300 RF, DIN10 to 25
Bearing type (※1)			1	-									Standard bearings (Special carbon)
			5	-									Ceramic bearings (Depends on liquid kind.)
			7	-									Polymerization-inhibited ceramics bearings (Depends on liquid kind.)
			8	-									Polymerization-inhibited carbon bearings (Special carbon)
Register type (※2)			A										Basic ULTRA model
			B										Batch controller equipped ULTRA register (LW74E/LW76E)
Register configuration			3										Non-explosionproof (Battery powered)
			4										TIIS explosionproof (Battery powered)
			5										ATEX explosionproof (※3)
			6										FM explosionproof (※3)
			7										NEPSI explosionproof (Battery powered)
Types of output signal (Register code A only.)			0	0									No output signal, Local LCD only (w/battery unit)
			0	1									Unscaled pulse (Current pulse) 2 wires
			0	2									Scaled pulse (Current pulse) 2 wires
			0	5									Unscaled pulse (Open collector pulse) 3 wires
			0	6									Scaled pulse (Open collector pulse) 3 wires
			0	7									Unscaled pulse (Voltage pulse) 3 wires
			0	8									Scaled pulse (Voltage pulse) 3 wires
			1	0									Analog 2 wires
			1	1									Analog + Unscaled pulse (Current pulse) 4 wires
		1	2									Analog + Scaled pulse (Current pulse) 4 wires	
Batch control function (Only register type B)			7	4									Pneumatic batch controller (LW74E register) 1-step open/1-step close type
			7	6									Pneumatic batch controller (LW76E register) 2-step open/2-step close type

※1 : Meter sizes 41 and 45 use the same body material SUS316 or 316L for rotors.  
Meter size 39 uses special carbon rotors only.

※2 : For register code B, see General Specification (No.GBC201E).

※3 : Code 3 applies only to the basic model of ULTRA register.

■ PRODUCT CODE EXPLANATION (Meter sizes 50 to 57)

Item	Code No.												Description	
	①	②	③	④	⑤	⑥	⑦	⑧	-	⑨	⑩	⑪		⑫
Type	L	U	S											ULTRA OVAL, Standard version (-10 to +120°C)
	L	U	H											ULTRA OVAL, high temp. service (120 to 260°C, Meter sizes 50: Max. 200°C)
	L	U	N											ULTRA OVAL, low temp. service (-60 to +60°C)
	L	U	J											Jacketed ULTRA OVAL (Meter sizes 52 thru 57 only)
	L	U	T											ULTRA OVAL, compatible with sharp temp. changes (-10 to +120°C)
	K	U	S											ULTRA OVAL, Standard Flowmeter (-10 to +60°C)
Meter size	5	0												Nominal size 20mm (3/4")
	5	2												Nominal size 25mm (1")
	5	3												Nominal size 25mm (1")
	5	5												Nominal size 40mm (1 1/2")
	5	6												Nominal size 50mm (2")
	5	7												Nominal size 50mm (2")
Body material	C													SUS316 (Rotors), SCS14 (Body)
	E													SUS316L (Rotors), SCS16 (Body) [Special]
Flange rating	1													JIS 10K RF, ASME, JPI 150 RF
	3													JIS16 to 30K RF, ASME, JPI 300 RF, DIN10 to 25 (Without high/low temperature, jacket)
Bearing type	1	-												Standard bearings (Special carbon)
	5	-												Ceramic bearings (Depends on liquid kind.)
	7	-												Polymerization-inhibited ceramic bearings (Depends on liquid kind.)
	8	-												Polymerization-inhibited carbon bearings (Special carbon)
Register type (※1)	A													Basic ULTRA model
	B													Batch controller equipped ULTRA register (LW74E/LW76E)
Register configuration	3													Non-explosionproof (Battery powered)
	4													TIIS explosionproof (Battery powered)
	5													ATEX explosionproof (※2)
	6													FM explosionproof (※2)
	7													NEPSI explosionproof (Battery powered)
Types of output signal (Only in case register type A is used.)	0	0												No output signal, Local LCD only (w/battery unit)
	0	1												Unscaled pulse (Current pulse) 2 wires
	0	2												Scaled pulse (Current pulse) 2 wires
	0	5												Unscaled pulse (Open collector pulse) 3 wires
	0	6												Scaled pulse (Open collector pulse) 3 wires
	0	7												Unscaled pulse (Voltage pulse) 3 wires
	0	8												Scaled pulse (Voltage pulse) 3 wires
	1	0												Analog 2 wires
	1	1												Analog + Unscaled pulse (Current pulse) 4 wires
	1	2												Analog + Scaled pulse (Current pulse) 4 wires
Batch control function (Only register type B)	7	4												Pneumatic batch controller (LW74E) 1-step open/1-step close type
	7	6												Pneumatic batch controller (LW76E) 2-step open/2-step close type

※1 : For register code B, see General Specification Sheet (No.GBC201-E)

※2 : Code 2 applies only to the basic model of ULTRA register.

■ OUTLINE DIMENSIONS [Standard register type A provided] (Unit in mm)

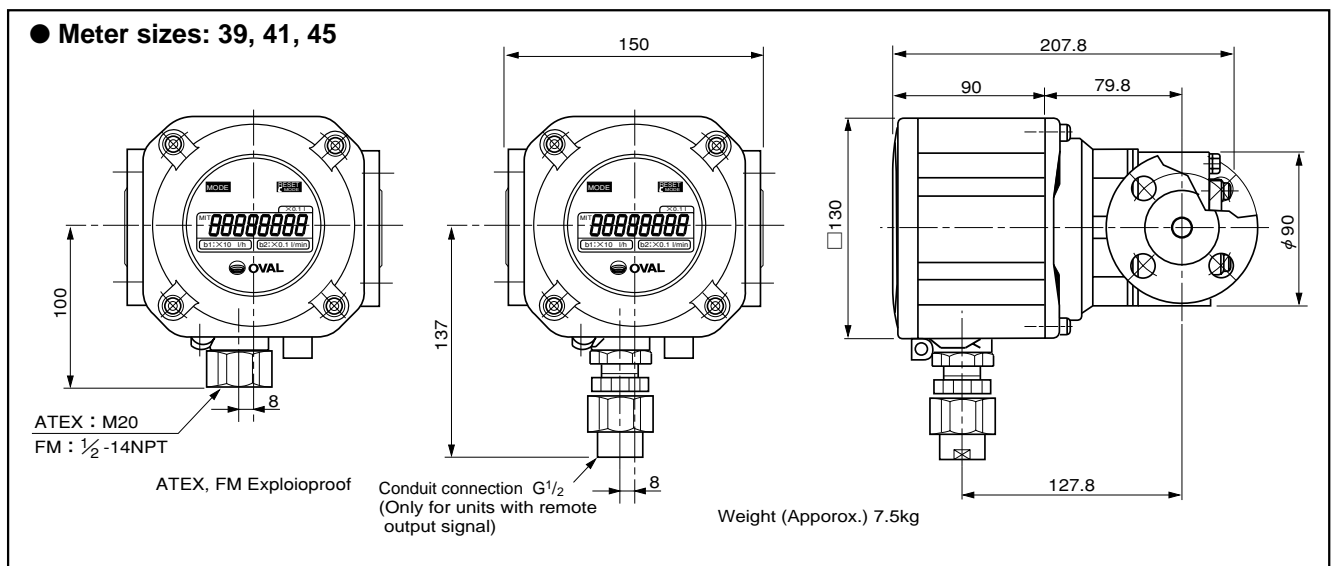

Note: 1. For batch controller equipped ULTRA register, refer to General Specification (No. GBC201E).

■ **OUTLINE DIMENSIONS [Standard ULTRA register type A provided] (Unit in mm)**

● **Standard (Types: LUS, LUT, KUS)**

● **Meter sizes : 50, 52, 53, 55, 56**

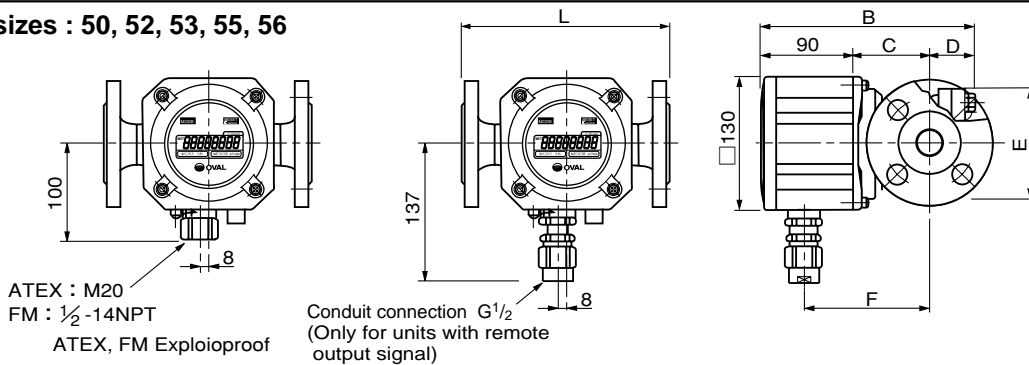

**1. Flange rating 1 group**

Meter size	Flange rating	L	B	C	D	E	F	Weight (Approx.)
50	JIS 10K RF	200	216.8	86.8	40	∅96	134.8	9kg
	ASME/JPI 150 RF	198						
52	JIS 10K RF	200	207.8	74.8	43	□106	122.8	10kg
	ASME/JPI 150 RF	200						
53	JIS 10K RF	200	231.3	85.8	55.5	□106	133.8	11kg
	ASME/JPI 150 RF	200						
55	JIS 10K RF	230	244.8	92.8	62	□130	140.8	16kg
	ASME/JPI 150 RF	233						
56	JIS 10K RF	250	269.8	106.8	73	□154	154.8	20kg
	ASME/JPI 150 RF	258						

**2. Flange rating 3 group**

Meter size	Flange rating	L	B	C	D	E	F	Weight (Approx.)
50	JIS 20K RF	204	216.8	86.8	40	96	134.8	12kg
	JIS 30K RF	208						
	ASME/JPI 300 RF	204						
52	JIS 20K RF	204	207.8	74.8	43	106	122.8	13kg
	JIS 30K RF	212						
	ASME/JPI 300 RF	207						
53	JIS 20K RF	204	231.3	85.8	55.5	106	133.8	14kg
	JIS 30K RF	212						
	ASME/JPI 300 RF	207						
55	JIS 20K RF	234	248.8	94.8	64	163	142.8	22kg
	JIS 30K RF	242						
	ASME/JPI 300 RF	240						
56	JIS 20K RF	254	271.8	109.8	72	193	157.8	26kg
	JIS 30K RF	262						
	ASME/JPI 300 RF	263						

● **Meter size : 57**

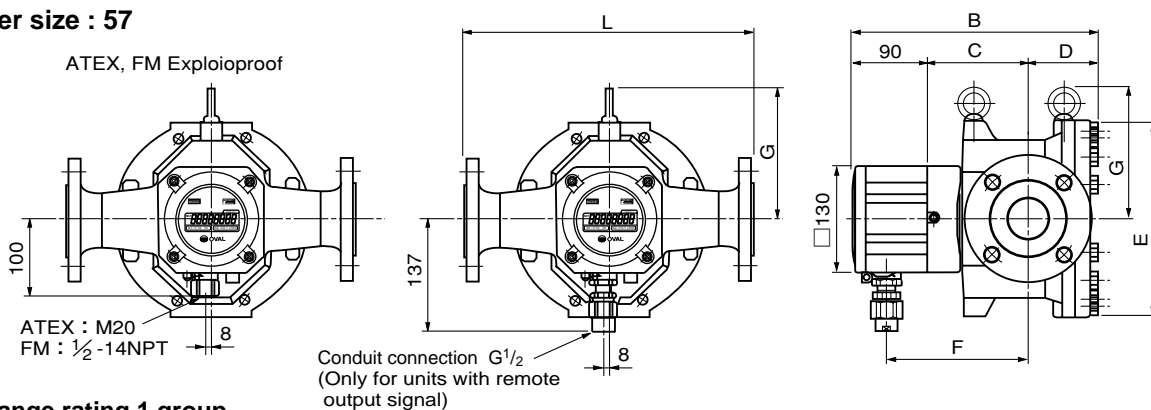

**1. Flange rating 1 group**

Meter size	Flange rating	L	B	C	D	E	F	G	Weight (Approx.)
57	JIS 10K RF	350	299.8	124.8	85	∅240	172.8	171.5	36kg
	ASME/JPI 150 RF	357							

**2. Flange rating 3 group**

Meter size	Flange rating	L	B	C	D	E	F	G	Weight (Approx.)
57	JIS 20K RF	354	308.8	131.8	87	∅260	179.8	171.5	47kg
	JIS 30K RF	362							
	ASME/JPI 300 RF	363							

In case the other Flange rating dimensions are requested consult factory.

Note: For batch controller equipped ULTRA register, refer to General Specification (No. GBC201E).

**OUTLINE DIMENSIONS [Standard ULTRA register type A provided] (Unit in mm)**

**With cooling or heating tube (Types: LUH, LUN)**

**Metersize : 52, 53**

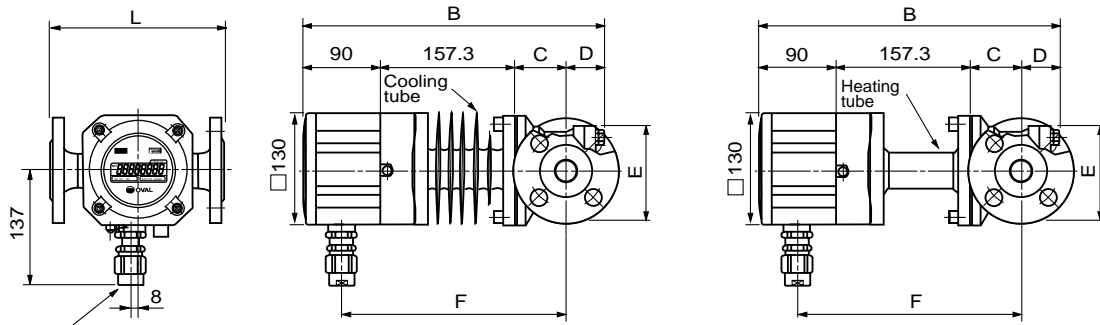

Conduit connection G<sup>1</sup>/<sub>2</sub> (female)  
(Only for units with remote output signal)

**Flange rating 1 group**

Meter size	Flange rating	L	B (Overall length)	C	D	E	F	Weight (Approx.)
52	JIS 10K RF	200	353.3	59	47	□106	264.3	W/Cooling tube 17kg
	ASME/JPI 150 RF	200						W/Heating tube 16kg
53	JIS 10K RF	200	376.8	70	59.5	□106	275.3	W/Cooling tube 18kg
	ASME/JPI 150 RF	200						W/Heating tube 17kg

**Metersize : 55, 56**

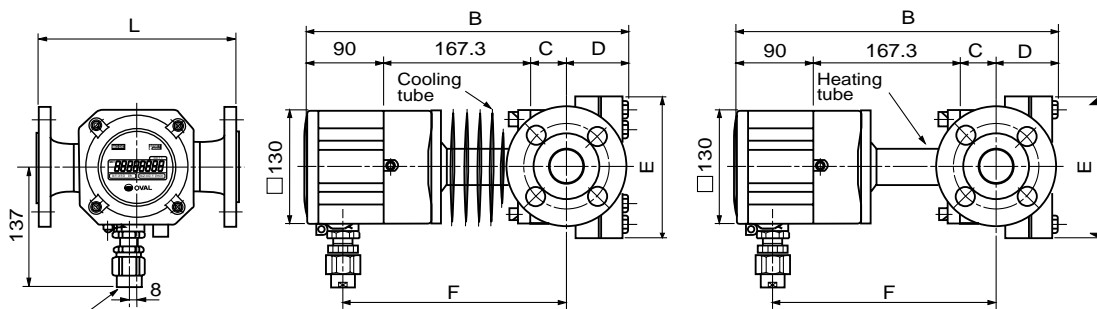

Conduit connection G<sup>1</sup>/<sub>2</sub> (female)  
(Only for units with remote output signal)

**Flange rating 1 group**

Meter size	Flange rating	L	B	C	D	E	F	Weight (Approx.)
55	JIS 10K RF	230	371.3	43	71	ø163	258.3	W/Cooling tube 23kg
	ASME/JPI 150 RF	233						W/Heating tube 22kg
56	JIS 10K RF	250	391.3	63	76	ø193	273.3	W/Cooling tube 27kg
	ASME/JPI 150 RF	258						W/Heating tube 26kg

**Metersize : 57**

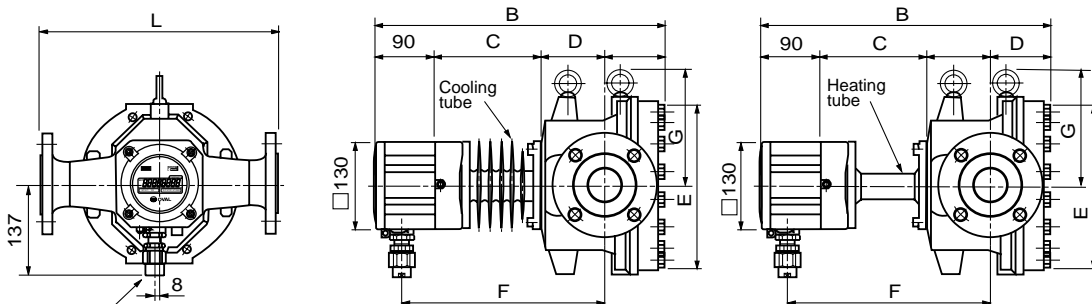

Conduit connection G<sup>1</sup>/<sub>2</sub> (female)  
(Only for units with remote output signal)

**Flange rating 1 group**

Meter size	Flange rating	L	B	C	D	E	F	G	Weight (Approx.)
57	JIS 10K RF	350	424.3	90	87	ø260	295.3	171.5	W/Cooling tube 43kg
	ASME/JPI 150 RF	357							W/Heating tube 42kg

Note: For batch controller equipped ULTRA register, refer to General Specification (No. GBC201E).

■ **OUTLINE DIMENSIONS [Standard ULTRA register type A provided] (Unit in mm)**

● **Jacketed type (Type: LUJ)**

● **Meter sizes : 52, 53**

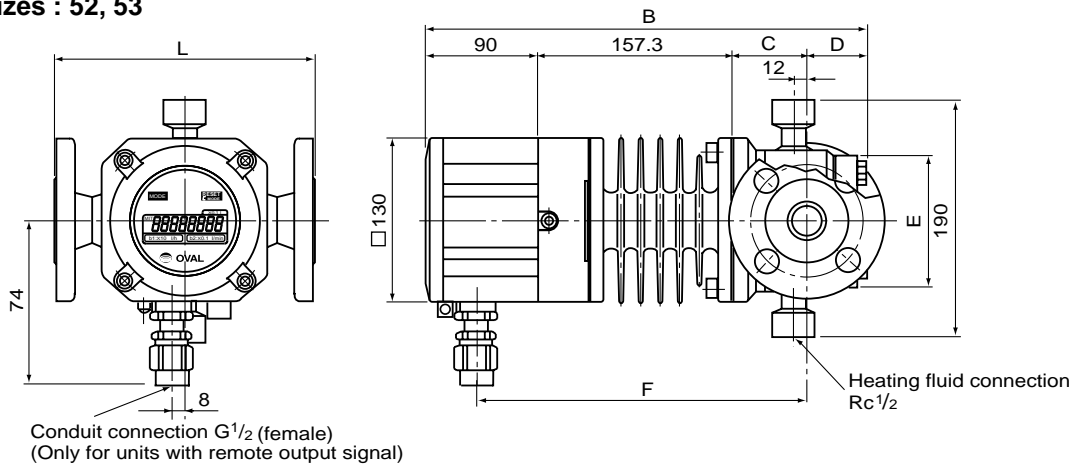

Meter size	Flange rating	L	B	C	D	E	F	Weight (Approx.)
52	JIS 10K RF	200	352.8	58.5	47	□106	263.8	13kg
	ASME/JPI 150 RF	200						
53	JIS 10K RF	200	376.3	69.5	59.5	□106	274.8	13.7kg
	ASME/JPI 150 RF	200						

● **Meter sizes : 55, 56**

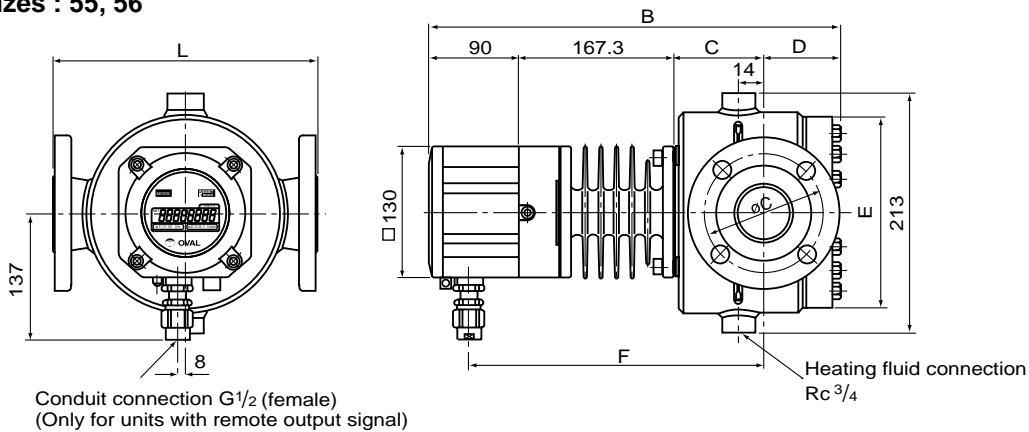

Meter size	Flange rating	L	B	C	D	E	F	Weight (Approx.)
55	JIS 10K RF	250	396.3	69	70	∅163	283.3	25kg
	ASME JPI 150 RF	253						
56	JIS 10K RF	300	423.3	89	77	∅193	299.3	31kg
	ASME JPI 150 RF	306						

● **Meter size : 57**

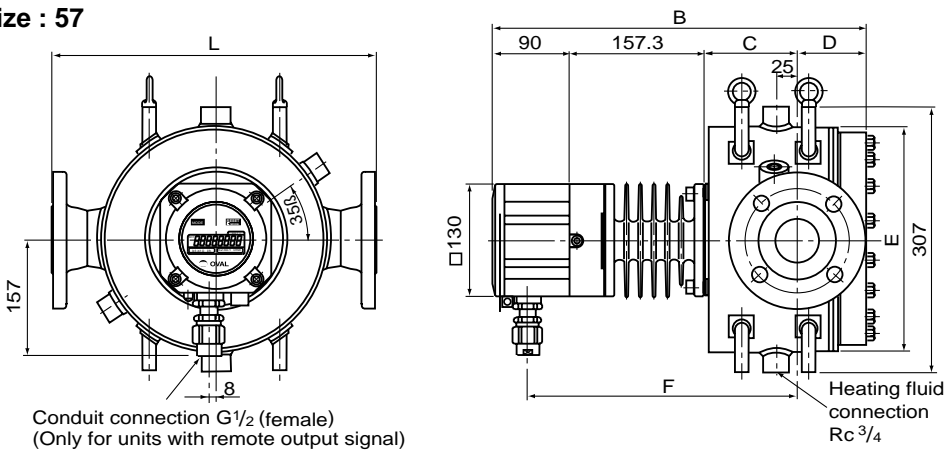

Meter size	Flange rating	L	B	C	D	E	F	Weight (Approx.)
57	JIS 10K RF	350	451.8	117.5	87	∅260	322.8	52kg
	ASME/JPI 150 RF	357						

■ STRAINERS

It is essential that a strainer be provided immediately upstream of, or as close as to, the flowmeter to prevent solids suspended in the process fluid from entering the meter, possibly leading to costly downtime.

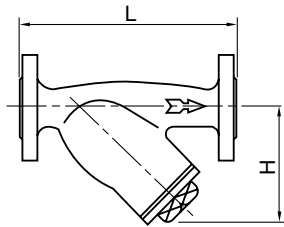

SR0 $\frac{1}{2}$ 3 $\frac{C}{(E)}$ 03 $\frac{1}{3}$

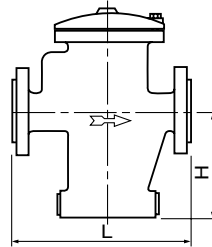

SR0 $\frac{3}{8}$ 1 $\frac{C}{(E)}$ 031

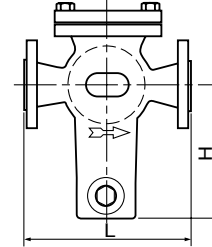

SR0 $\frac{3}{8}$ 8 $\frac{C}{(E)}$ 032

Model number	Nominal size	Flange rating	L (mm)	H (mm)	Body material	Screen material	Std. screen mesh	Applicable meters
SR013C031	10mm	JIS 10K RF	180	100	SCS14A	SUS316	200	39
SR013C032		ASME/JPI 150 RF	178					
SR013C032		JIS 20K RF	184	126				
		JIS 30K RF	188					
		ASME/JPI 300 RF	185				45	
SR023 $\frac{C}{(E)}$ 031	20mm	JIS 10K RF	180	100	SCS14A (SCS16A)	SUS316 (SUS316L)	200	50
SR023 $\frac{C}{(E)}$ 032		ASME/JPI 150 RF	177					
SR023 $\frac{C}{(E)}$ 032		JIS 20K RF	184					
SR031 $\frac{C}{(E)}$ 031	25mm	JIS 10K RF	230	165	SCS14A (SCS16A)	SUS316 (SUS316L)	100	52
SR038 $\frac{C}{(E)}$ 032		ASME/JPI 150 RF	231	209				
SR038 $\frac{C}{(E)}$ 032		JIS 20K RF	234					
SR041 $\frac{C}{(E)}$ 031	40mm	JIS 10K RF	230	165	SCS14A (SCS16A)	SUS316 (SUS316L)	60	55
SR048 $\frac{C}{(E)}$ 032		ASME/JPI 150 RF	233	209				
SR048 $\frac{C}{(E)}$ 032		JIS 20K RF	234					
SR051 $\frac{C}{(E)}$ 031	50mm	JIS 10K RF	290	190	SCS14A (SCS16A)	SCS316 (SCS316L)	60	56
SR058 $\frac{C}{(E)}$ 032		ASME/JPI 150 RF	296	242				
SR058 $\frac{C}{(E)}$ 032		JIS 20K RF	294					

**■ REQUIRED SPACE AROUND THE METER**

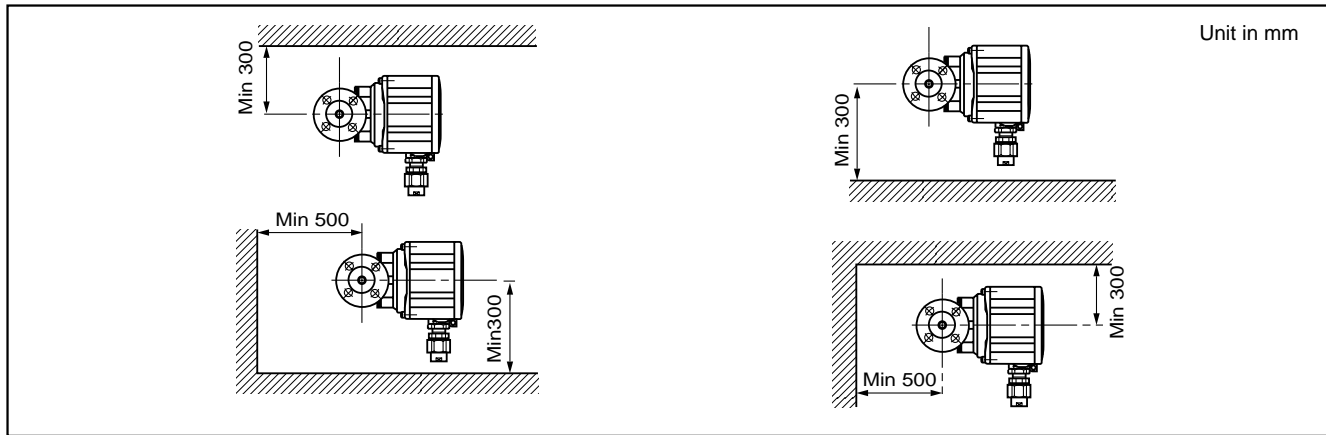

**■ OPERATING PRECAUTIONS**

1. Every OVAL flowmeter is carefully assembled and precisely adjusted to measure flows down to minute flows before it leaves the factory. Take every precaution in uncrating, installation in the piping assembly, and testing.
2. Never allow foreign solids to enter the measuring chamber.
3. Flush the piping assembly thoroughly.
4. Avoid allowing the meter rotors to spin uncontrolled by directing a stream of air, etc. or allowing the fluid to flow excessively - even momentarily.
5. It is essential that a strainer (supplied by OVAL) exclusively designed for OVAL flowmeters be used.
6. This flowmeter is not provided with subtract function. If pulsation in the flow (where the fluid moves back and forth in the pipeline under the influence of pressure) or reversal of flow exists, the total counter may show erratic reading, accumulating all incoming pulses irrespective of flow direction.

**■ ORDERING INFORMATION**

Please complete the following form when making inquiries.

1. Model	L _____ <input type="checkbox"/> Standard <input type="checkbox"/> High temp. <input type="checkbox"/> Low temp. <input type="checkbox"/> Jacketed
2. Fluid to be measured	Name _____ Viscosity _____ mPa·s Specific gravity _____
3. Flowrate (L/h, m³/h)	Maximum _____ Normal _____ Minimum _____
4. Fluid temperature (°C)	Maximum _____ Normal _____ Minimum _____
5. Ambient temperature (°C)	Maximum _____ Normal _____ Minimum _____
6. Pressure (MPa)	Maximum _____ Normal _____ Minimum _____
7. Flow direction	Right ⇌ Left, Bottom ⇌ Top
8. Flange connection	Nominal size _____ mm, Flange rating _____
9. Required linearity	± _____ %
10. Explosionproof configuration	<input type="checkbox"/> Non-explosionproof <input type="checkbox"/> TIIS <input type="checkbox"/> ATEX <input type="checkbox"/> FM <input type="checkbox"/> NEPSI Pressure-resistant packing (selectable only for ATEX or FM) <input type="checkbox"/> Required <input type="checkbox"/> Not required
11. Accessories	<input type="checkbox"/> Strainer, <input type="checkbox"/> Air eliminator, <input type="checkbox"/> Companion flange
12. Quantity	Including accessories _____
13. Application	_____ (dosing, sampling, blending process, etc.) <input type="checkbox"/> Flow integration, <input type="checkbox"/> Flow indication, <input type="checkbox"/> Record, <input type="checkbox"/> Flow control, <input type="checkbox"/> Batch control, <input type="checkbox"/> CPU interface, <input type="checkbox"/> Others
14. Receiving instrument	Type, manufacturer, model, specifications (input, output, power supply, etc.)
15. Distance between flow meter and receiving instrument	_____ m

The specification as of Dec., 2010 is stated in this GS Sheet. Specifications and design are subject to change without notice.



**Sales Representative:**  
**icenta CONTROLS Ltd**  
 North Station Yard, Warminster Road, Wilton, Salisbury, SP2 0AT  
 Tel: 0845 895 1020 Fax: 0845 895 1021  
 Email: sales@icenta.co.uk  
 www.icenta.co.uk