



Big bore size, High performance coriolis flowmeter

ULTRAmass MKII "CN100"

Transmitter : CT9401

GENERAL SPECIFICATION

GS.No.GBN056E-2

■ GENERAL

The know-how and experience gained in our specialized domain of manufacturing flowmeters have been used in the development of a new general-purpose coriolis flowmeter, the ULTRAmass MKII, which is characterized by ease of operation, increased performance and safety for the plant operator.

■ FEATURES

1. Exceptional accuracy ($\pm 0.1\%$ \pm zero stability error of reading for liquid service) and high sensitivity (measuring range 1 to 100).
2. Accepts both liquid measures accurately with small pressure loss over a broad flow range.
3. Measures density and temperature accurately in addition to mass flowrate.
4. Minimum pockets for the process fluid to stand (in vertical installation) offers ease of cleaning.
5. Applicable to many kinds of process fluids thanks to stainless steel components.
6. Exceptionally high mechanical strength. The result is ease of handling, installation space saving, and increased process safety.



Transmitter CT9401
(Separated type)



7. The transmitter has a touch panel for readily selecting menu items on the display, such as flowrate, density, and temperature.
8. Explosionproof construction permits meter installation in a hazardous location.
9. Can produce an alarm output when preset density range is exceeded due to bubble entrapment, for example. (option)

■ GENERAL SPECIFICATIONS

● Sensor unit

Item	Description	
Model	CN100	
Nominal size	100mm or 4" 150mm or 6"	
Materials	SUS316L	
Wetted Housing	SUS304	
Process connection	JIS 10, 20, 30K RF, ANSI/JPI 150, 300, 600RF	
Applicable fluids	Liquids	
Density range	0.3 to 2 g/mL	
Viscosity range	Max. 1000mP·s	
Temperature range	Non-explosionproof type	
	Ex. temp. grade T3	-200 to +200°C
	Ex. temp. grade T4	-20 to +120°C
	Tube withstand (at 20°C)	-20 to +90°C
Max. operating pressure	13.56MPa (Reference : 9.39MPa at 200°C)	
Flow direction	Depends on flange rating	
Explosionproof	Forward and reverse, both available	
	Intrinsically safety explosionproof (ExibIIBT3 or ExibIIBT4)	

※ : Miscellaneous: For products conforming to the high pressure gas safety regulations and consult our representative.

● Transmitter

Item	Description
Model	CT9401 (sophisticated model)
Power supply	85 to 264VAC 50/60Hz or 20 to 30VDC
Power consumption	Max. 25VA or Max. 10W
Ambient temperature	-20 to +50°C (Non condensing)
Transmission length (separate type)	Max. 200m (Exclusive cable used) (※2)
Explosionproof enclosure	TIIS : Exd[ib] IIBT4
Dust and waterproof construction	IP66
Mounting	Integrate or separate mounting
Display	8-digit (7-segment) LDC display
Weight	5.8kg approx.,
Communication interface	HART protocol Bell 202
Status input	Contact-closure input (Form "a" contact) Close: 200Ω max., Open: 100kΩ min. Select one from Function OFF (default), remote zero, total reset, and 0% signal lock.
Pulse output (※1)	Open collector output (10V min. to 30Vmax., 50mA DC) or, Voltage pulse (option) "0": 1.5V max. "1": 15V, Output impedance 2.2kΩ, FS:0.1 to 10000Hz
Analog output (※1)	4 to 20mADC (max. load 600Ω) Two outputs from instantaneous flow rate (mass, volume) temperature or density. Damping (std.): flow rate 1sec, density 4sec, temperature 2.5sec.
Status output	Open collector output Normal: ON; Abnormal: OFF (Max.30V, 50mADC) Select one from Error (std.), flow direction, Hi/Lo alarm

(※1) : Flowrate signal is cut off below 0.6% of max. service flowrate.

(※2) : If it exceeds 200 meters, consult factory.

OVAL Corporation

<http://www.oval.co.jp>

Head Office (Tokyo): Tel. 81-3-3360-5121. Fax. 81-3-3365-8605

Beijing Office: Tel. 86-10-5867-4711. Fax. 86-10-5867-4713

Overseas Branch Offices: Seoul, Singapore and Taipei

■ GENERAL SPECIFICATIONS

Item	Description	
Model	CN100	
Flow rate (Liquids)	Normal flow range (kg/min)	0 to 5700
	Allowable flow range (kg/min)	0 to 6200
	Min. range (kg/min)	0 to 285
	Lower limit rate (kg/min)	57
	Accuracy in factory calibration	[±0.1% ± zero stability error] of RD
Density (Liquids)	Repeatability	[±0.05% ± 1/2 zero stability error] of RD
	Zero stability (kg/min)	0.57
	Measuring range	0.3 to 2g/mL
Analog accuracy	Accuracy in factory calibration (option)	±0.001g/mL
		±0.1% of FS added to each accuracy

$$\text{Zero stability error} = \frac{\text{Zero stability (kg/min)}}{\text{Flow rate at that time (kg/min)}} \times 100\%$$

※ : For volume flowrate measurement in custom or custody transfer application, contact us.

■ DISPLAY

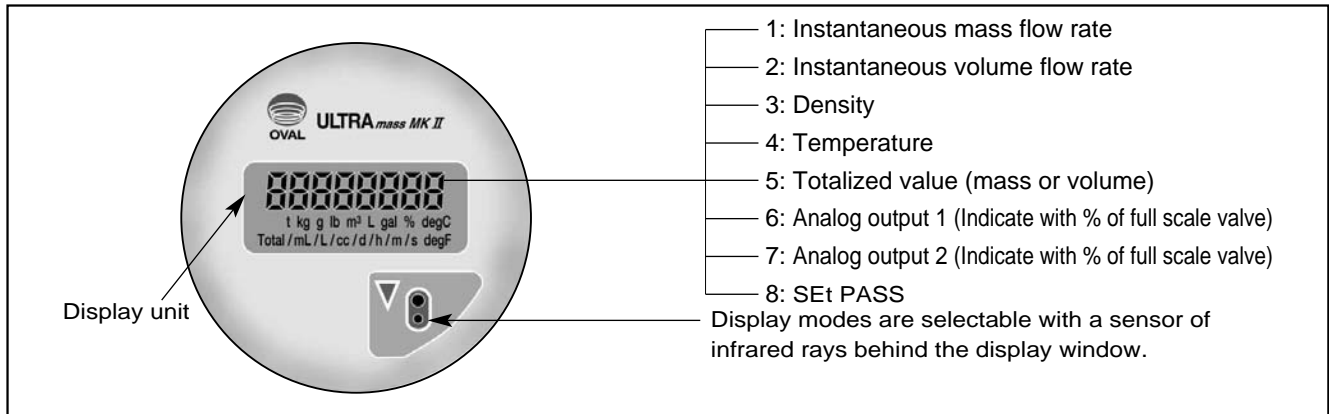

■ METER ERROR

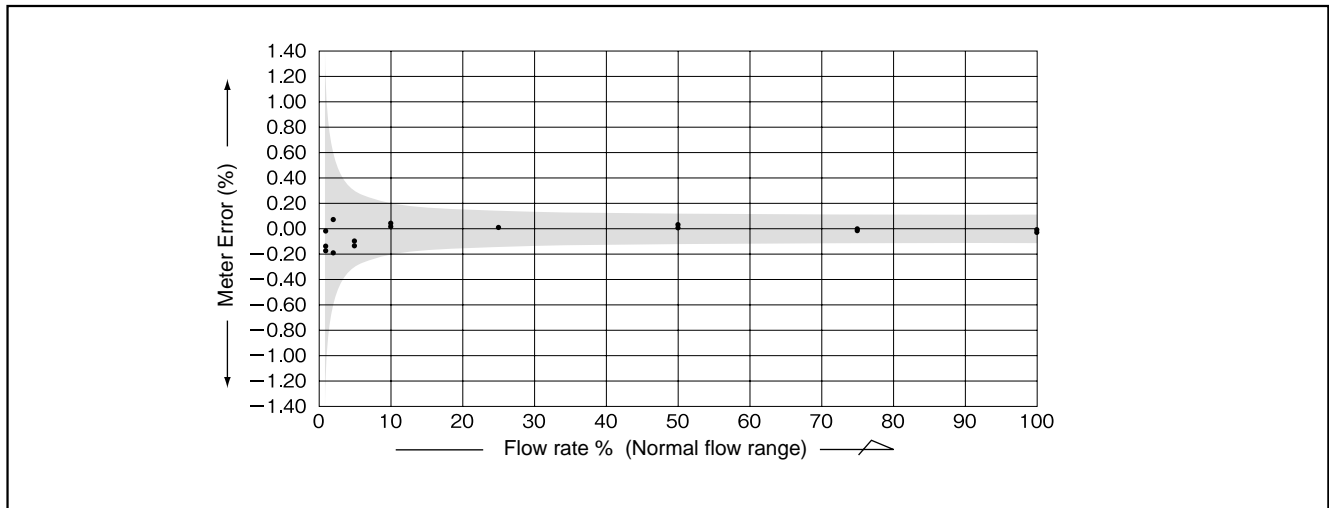

■ PRESSURE LOSSES

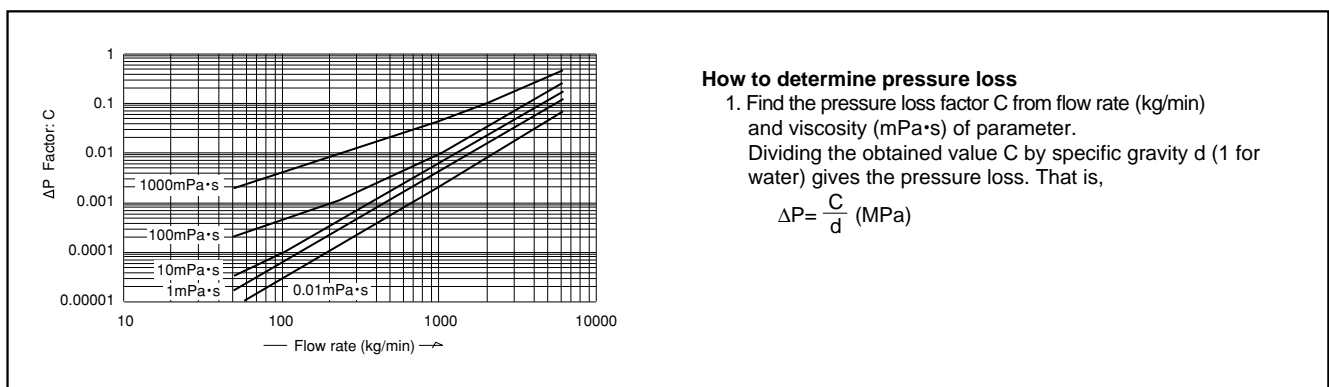

How to determine pressure loss

1. Find the pressure loss factor C from flow rate (kg/min) and viscosity (mPa·s) of parameter. Dividing the obtained value C by specific gravity d (1 for water) gives the pressure loss. That is,

$$\Delta P = \frac{C}{d} \text{ (MPa)}$$

■ HOOKUP WITH RECEIVING INSTRUMENTS

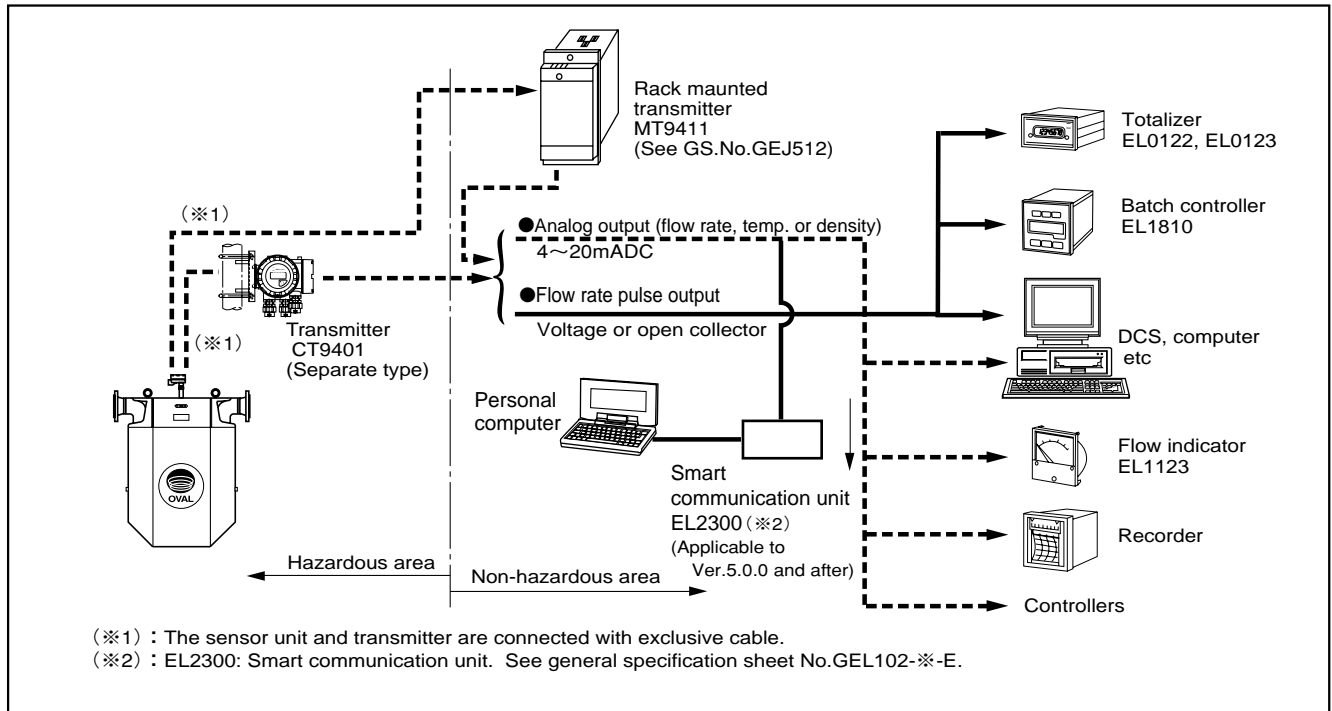

■ PRODUCT CODE EXPLANATION

● Sensor unit

Item	Code No.												Description
	①	②	③	④	⑤	⑥	⑦	⑧	⑨	⑩	⑪	⑫	
Model	C	N											ULTRA mass MK II
Nominal size	1	0	0										100 mm (4") or 150 mm (6")
Configuration	A		—										CN100, Nominal size 100mm (4")
	B		—										CN100, Nominal size 150mm (6")
Material	S		S		—								SUS316L
Connection type	3											Flange connection	
Connection standard	1											JIS	
	2											ANSI	
	3											JPI	
Pressure rating	1											10K	
	2											20K, ANSI 150, JPI 150	
	3											30K, ANSI 300, JPI 300	
	6											ANSI 600, JPI 600	
Transmitter mounting construction	R											CT9401(Separated type) or MT9411(Rack mounted type)	

● Standard type transmitter

Item	Code No.						Supplemental Code						Description
	①	②	③	④	⑤	⑥	⑦	⑧	⑨	⑩	⑪	⑫	
Model	C	T	9	4	0	1	—						Local mount transmitter (CT9401)
Configuration	R						—						Separate type
Power supply	6						—						20 to 30VDC
	7						—						85 to 264VAC 50/60Hz
Analog output (※1)	M						M						Mass flow rate analog 2 output
	M						D						Mass flow + Density
	M						T						Mass flow + Temperature
	M						V						Mass flow + Volume flow
	D						T						Density + Temperature
	V						D						Volume flow + Density
	V						T						Volume flow + Temperature
	M						X						Mass flow rate 1 output (Voltage pulse output)
	D						X						Density 1 output (Voltage pulse output)
V						X						Volume flow 1 output (Voltage pulse output)	
Pulse output	1						—						Mass flow voltage pulse (option)
	2						—						Volume flow voltage pulse (option)
	3						—						Mass flow open collector pulse
	4						—						Volume flow open collector pulse
Explosionproof	0												Non-explosionproof
	1												TIIS (domestic explosionproof) (Temp. grade:Sensor T3, Transmitter T4)
	3												TIIS (domestic explosionproof) (Temp. grade:Sensor T4, Transmitter T4)
	7												NEPSI (chinese explosionproof) (Temp. grade:Sensor T3, Transmitter T4)
	A												NEPSI (chinese explosionproof) (Temp. grade:Sensor T4, Transmitter T4)

(※1) : If voltage pulse output is chosen for pulse output, the analog output 2 is not available; select "X" in model code place⑩.

■ OUTLINE DIMENSIONS [Unit in mm]

● Sensor unit

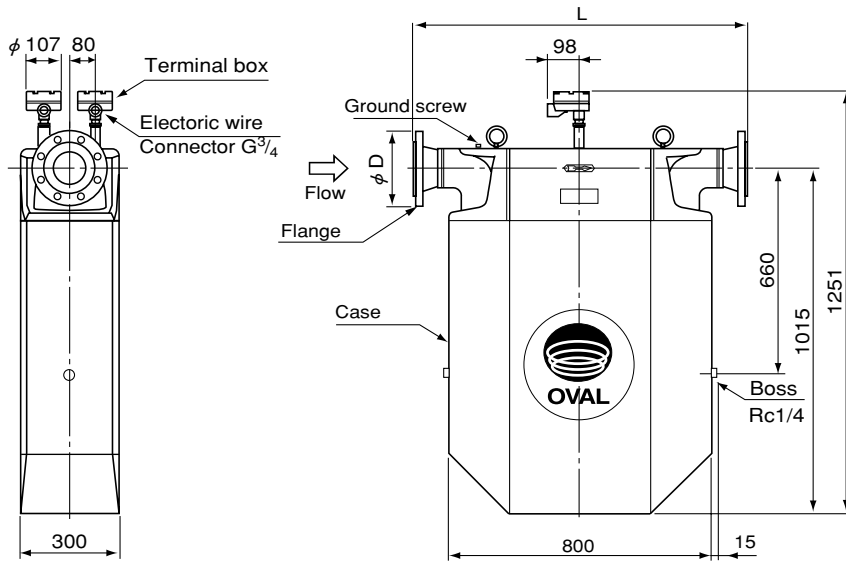

Model	Flange		L	ϕD	Approx. weight kg
	Nom. size	Con. standard			
CN100	100mm	JIS 10K	992	210	231
		JIS 20K	1006	225	235
		JIS 30K	1016	240	241
	4"	ANSI, JPI 150	1018	230	237
		ANSI, JPI 300	1036	255	245
		ANSI, JPI 600	1082	275	255
	150mm	JIS 10K	1300	280	246
		JIS 20K	1320	305	253
		JIS 30K	1330	325	265
	6"	ANSI, JPI 150	1318	280	248
		ANSI, JPI 300	1338	320	265
		ANSI, JPI 600	1388	355	292

Local mount type transmitter (CT9401)
 <Stanchion type>
 (Mounting hardware furnished)

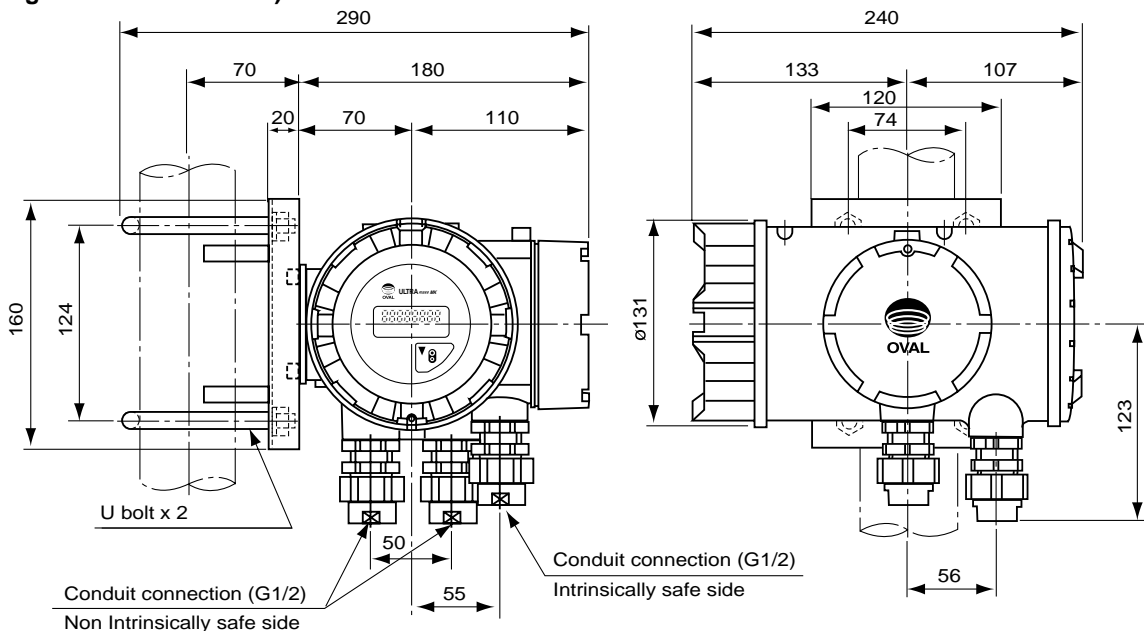

■ WIRING FOR CT9401

● Transmitter power and output signal connections

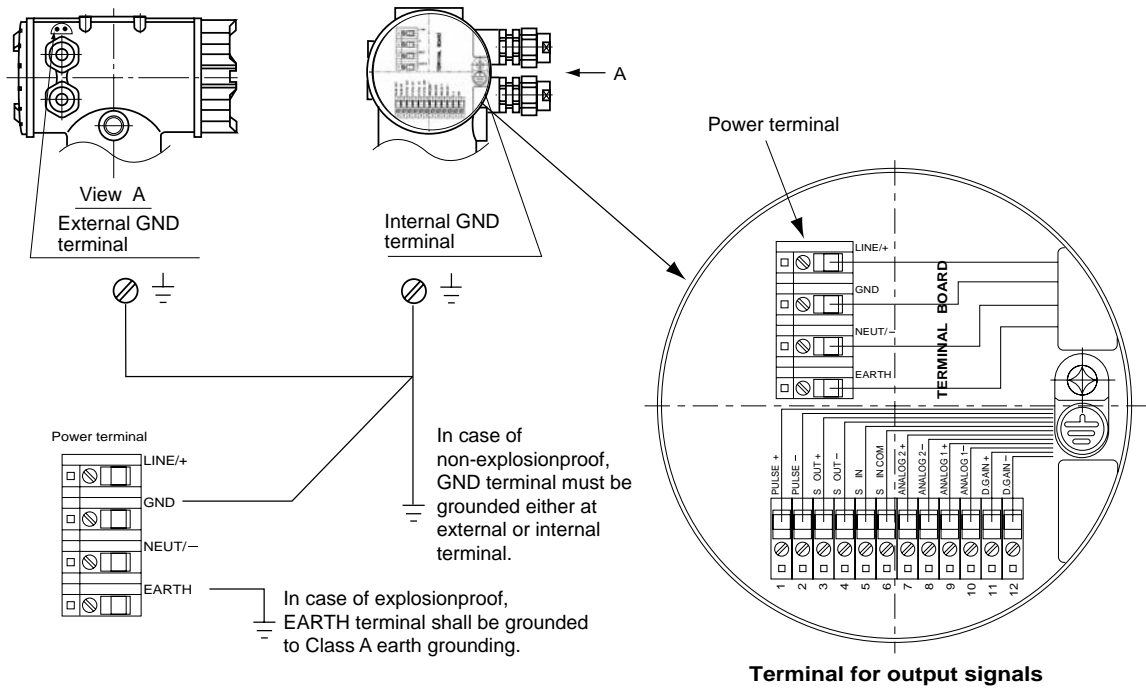

● Remote output signal connection terminals

Item	Terminal No.	Label	Description	Remarks
Output signal	1	PULSE +	Pulse output	1. Use shielded twisted pairs AWG24-16 for output wiring. 2. Max. load resistance is 600Ω for analog output 1 and 2. 3. Pulse output (voltage pulse) transmission length is Max. 10m (at 10kHz) Max. 100m (at 1kHz) Max. 1km (at 100Hz)
	2	PULSE -		
	3	S OUT +	Status output, open collector output	
	4	S OUT -	Normal: ON; Abnormal: OFF	
	5	S IN	Status input (Form "a" contact input)	
	6	S IN COM		
	7	ANALOG2+	Analog output 2 (※1)	
	8	ANALOG2-	Analog output 1	
	9	ANALOG1+		
	10	ANALOG1-		
Power		LINE/+	Power (with DC power: +)	Be sure to earth ground at GND or EARTH terminal.
		GND	Class "D" earth ground work	
		NEUT/-	Power (with DC power: -)	
		EARTH	Class "A" earth ground work	

(※1) : When voltage pulse output specification is your option, analog output 2 is not serviceable. Leave terminals 7 and 8 for analog output 2 open; Never make wiring connections.

● Terminal identification between separate type sensor unit and transmitter

Item	Terminal No. (Cable color)	Label	Description	Remarks
Sensor to transmitter	Black	SHIELD	Bundle BWN/RED, GRN/WHY, BLU/GRY, ORG/PUR/YEL shield wires.	Exclusive cable shall be used. Transmission length 200 meters max.
	Brown	(+) DRIVE	Flow tube drive output	
	Red	(-) DRIVE		
	Orange	TEMP B	Temperature input	
	Yellow	TEMP b	Temperature input	
	Green	(+) LPO	Left position pickoff input	
	Blue	(+) RPO	Right position pickoff input	
	Purple	TEMP A	Temperature input	
	Grey	(-) RPO	Left position pickoff input	
	White	(-) LPO	Right position pickoff input	

■ WIRING FOR CT9401

● Sensor unit to transmitter connections

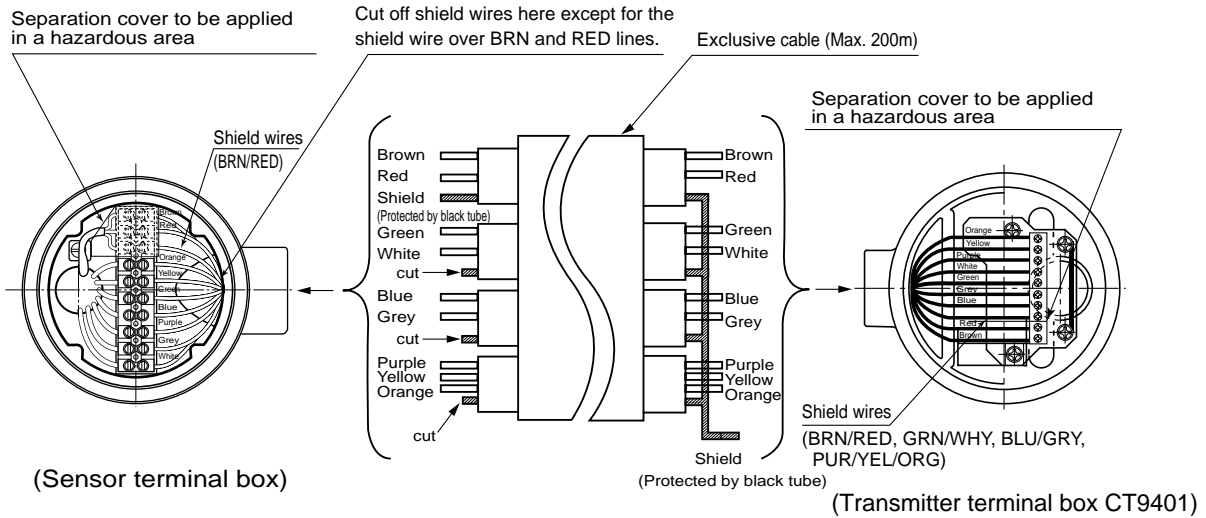
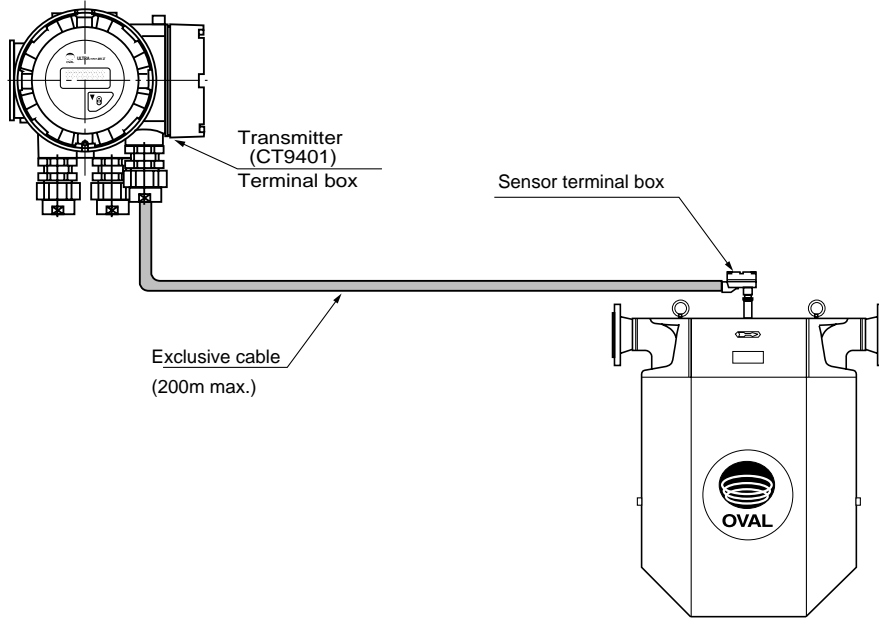

- NOTE 1. Do not fail to use exclusive cable.
 2. Shield wire preparation
 (1) Transmitter end:
 Bundle the shield wires corresponding with brown/red, green/white, blue/grey, purple/orange/yellow and slip a black sleeve over them as shown in the figure, exercising care to avoid potential contact with the housing and other conductive parts.
 (2) Sensor end:
 Slip a black sleeve over the shield wires corresponding with brown/red pair cable as shown in the figure, exercising care to avoid potential contact with the housing and other conductive parts. Clip all other shield wires.
 3. The CN100 has two terminal boxes, one for normal service; the other for reserve. Application notes for the terminal box in reserve appear in the instruction manual.
 4. Two outputs are not available simultaneously from each terminal box.

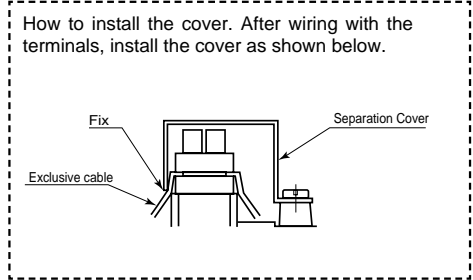

■ STANDARD INSTALLATION

1. Typical installation (See figure at right.)

- 1) Avoid pipeline stresses on the ULTRAmass MKII.
- 3) The ULTRAmass MKII should be supported at the process pipelines near to the connections with the meter.
- 3) Avoid supporting the ULTRAmass MKII body directly.
- 4) Pipeline should be arranged such that the ULTRAmass MKII is constantly filled with the process fluid. Avoid, however, to install it in a pocket where slurries may build up.
- 5) Provide a valve downstream of the meter to allow zeroing by obtaining a true zero flow. We recommend to provide another valve upstream of the meter for servicing or maintenance.

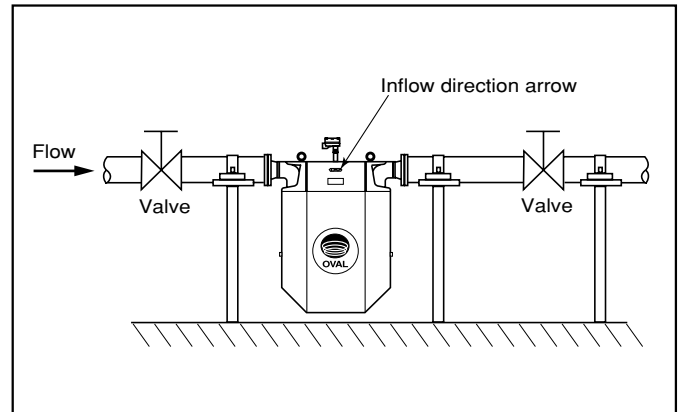

2. Precautions at installation

- 1) Locate the ULTRAmass MKII at least one meter from large transformers, motors, or other sources of electromagnetic induction. Also avoid installation near the sources of excessive vibration, such as motors and pumps.
- 2) If it is desired to make a measurement of a process fluid requiring heat retention, heat trace may be applied directly to the sensor body. Heat trace should be held below 200°C. Explosionproof models require the temperature to be held below their maximum allowable levels.
- 3) In density measurement, heat retention is suggested for stability of readings.
- 4) The sensor unit is of gastight construction. To prevent dew condensation inside in a low temperature application, it is filled with argon gas. For this reason, avoid dropping or giving it impact shocks.
- 5) A control valve should be located downstream of the ULTRAmass MK II. In an arrangement where cavitation may possibly take place, locate it at least 5 meters away.
- 6) To ensure consistent and accurate measurement, the Coriolis flowmeter should be placed in an environment where pipeline oscillation is held below 0.3G.

3. Physical orientation

Recommended physical orientation varies with the type of process fluid. No. 2 in the figure below shows the representative orientation for liquid service.

		Horizontal run		Vertical run
No.		1	2	3
Orientation				
	Fluids	<ul style="list-style-type: none"> ● Slurries 	<ul style="list-style-type: none"> ● Liquids 	<ul style="list-style-type: none"> ● Slurries (requires cleaning) ● Liquids

※ : Do not forget to specify the physical orientation when you order.

■ PLEASE SUPPLY THE FOLLOWING INFORMATION WHEN YOU INQUIRE

(Fill in the form below to the extent possible. Further details will be finalized in later consultation.)

• Fill in the blanks. Tick the boxes that apply.

1. Application		
2. Process fluid (※1)		Name : _____ SP. gr : _____ Viscosity : _____ Solution concentration : _____%
3. Nominal size		<input type="checkbox"/> 100mm or 4" <input type="checkbox"/> 150mm or 6"
4. Flanged connection		<input type="checkbox"/> JIS 10K <input type="checkbox"/> JIS 20K <input type="checkbox"/> JIS 30K <input type="checkbox"/> ANSI 150 <input type="checkbox"/> ANSI 300 <input type="checkbox"/> ANSI 600 <input type="checkbox"/> JPI 150 <input type="checkbox"/> JPI 300 <input type="checkbox"/> JPI 600
5. Flow range		Max. _____ Normal _____ Full scale _____ <input type="checkbox"/> kg/min <input type="checkbox"/> kg/h
6. Fluid temperature		Max. _____ °C Normal _____ °C Min. _____ °C
7. Operating pressure		Max. _____ MPa Normal _____ MPa Min. _____ MPa
8. Ambient temperature		Max. _____ °C Min. _____ °C
9. Fluid flow direction		<input type="checkbox"/> Left→Right <input type="checkbox"/> Right→Left <input type="checkbox"/> Bottom→Top (<input type="checkbox"/> Top →Bottom) Orientation : See sketch on page 7.
10. CE marking		<input type="checkbox"/> Not required <input type="checkbox"/> Required
11. Explosionproof		<input type="checkbox"/> Not required <input type="checkbox"/> TIIS/Temp. grade:Sensor T3 <input type="checkbox"/> TIIS/Temp. grade:Sensor T4
12. Power supply		<input type="checkbox"/> 20 to 30VAC <input type="checkbox"/> 85 to 264VAC (50/60Hz)
13. Output specifications	Pulse	<input type="checkbox"/> mass flow rate or <input type="checkbox"/> volume flow rate <input type="checkbox"/> Open collector (std.) or <input type="checkbox"/> Volt. pulse (Option, analog output has limitations.) Pulse freq. : _____ Hz (at full scale) or Pulse unit : _____ <input type="checkbox"/> kg/P <input type="checkbox"/> L/P
	Analog	<input type="checkbox"/> instant. flow rate (<input type="checkbox"/> ×2) <input type="checkbox"/> volume flow rate <input type="checkbox"/> temperature <input type="checkbox"/> density (2 outputs from, mass flow rate×2 selectable)
	Status	<input type="checkbox"/> Error (std.) <input type="checkbox"/> Flow direction <input type="checkbox"/> Hi/Low Alarm (Select only one.)
14. Receiver		<input type="checkbox"/> Totalizer <input type="checkbox"/> Indicator <input type="checkbox"/> Recorder <input type="checkbox"/> Flow controller <input type="checkbox"/> Batch controller <input type="checkbox"/> Computer <input type="checkbox"/> Others (_____)
15. Transmission distance		Sensor unit to Transmitter _____ m (200 meters max. using interconnect cable.) Transmitter to Receiving instrument _____ m
16. Other considerations		

(※1) : Special fluids, such as slurries, should be stated accurately and in detail.

The specification as of July, 2008 is stated in this GS Sheet. Specifications and design are subject to change without notice.



Sales Representative:
icenta CONTROLS Ltd
North Station Yard, Warminster Road, Wilton, Salisbury, SP2 0AT
Tel: 0845 895 1020 Fax: 0845 895 1021
Email: sales@icenta.co.uk
www.icenta.co.uk

GS.No.GBN056E

初版	改訂	印刷
07.10	08.7	