



OVAL Coriolis Mass Flowmeter
 High pres. type **ULTRAmass MKII**
 MODEL CN010, CN015

GENERAL SPECIFICATION
GS.No.GBN052-3-E

■ **GENERAL**

The know-how and experience gained in our specialized domain of manufacturing flowmeters have been used in the development of a new general-purpose coriolis flowmeter, the ULTRAmass MKII, which is characterized by ease of operation, increased performance and safety for the plant operator.

■ **FEATURES**

1. Exceptional accuracy ($\pm 0.2\%$ \pm zero stability error of reading for liquid service) and high sensitivity (measuring range 1 to 200).
2. Accepts both liquid and gas. Measures precisely with small pressure loss over a broad flow range.
3. Measures density and temperature accurately in addition to mass flowrate.
4. Minimum pockets for the process fluid to stand (in vertical installation) offers ease of cleaning.
5. Lightweight and compactly built, yet exceptionally high mechanical strength. The result is ease of handling, installation space saving, and increased process safety.

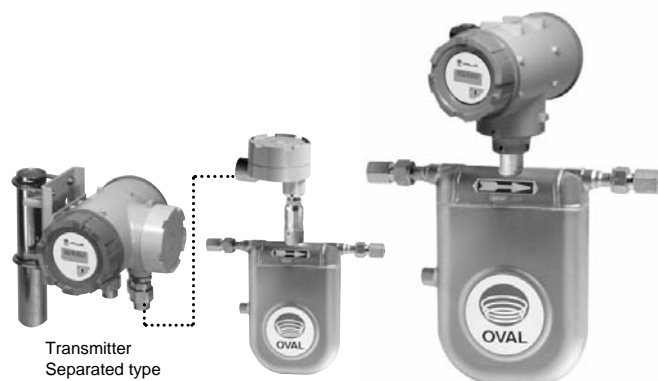

6. The transmitter comes in two types - integrally mounted to, or separately mounted from the sensor. Select one for your particular application.
7. Also available is a sophisticated transmitter with a local display to show variables, such as the flowrate, density, and temperature, at the touch of a display panel.
8. Explosionproof construction permits meter installation in a hazardous location.

■ **GENERAL SPECIFICATIONS**

● **Sensor unit**

Item		Description	
Model		CN010H (G)	CN015H (G)
Materials	Wetted	Hastelloy C22 , Equivalent Hastelloy (CX2MW)	
	Housing	SUS304	
Process connection		Screw Rc3/8	Screw Rc3/4
Applicable fluids		Liquids and gases	
Density range		0 ~ 2 g/mL	
Temperature range	Non-explosion-proof type	-200 ~ +200°C (For liquid Temp. above 120°C, the transmitter should be of separate-mount type)	
	Ex. temp. grade	T 3	-20 ~ +165°C
		T 4	-20 ~ +105°C
Max. operating pressure		36MPa at normal temperature	43MPa at normal temperature
Sensor housing with stands (MPa)		3.0 MPa	2.2 MPa
Installation		Horizontal mount or vertical mount	
Flow direction		Bidirectional	
Explosionproof construction		Intrinsically safety explosionproof (Exib II BT3 or Exib II BT4)	

NOTES: (1) Explosionproof temperature grade T4 rated sensors are integrally-mounted type only.
 (2) This pressure does not represent the withstanding pressure of pressure vessele ratings, but shows 1/4 the pressure of the breakdown test pressure (four-fold pressure test), accepting a deformed casing, or that in the FEM analysis, whichever is lower (safer level): it actually represents the withstanding pressure below 1/4 the breakdown pressure.
 (3) In applications where fluid and atmospheric temperature exceeds 130°C, select high-temperature service meters (see page 10).

OVAL Corporation

<http://www.oval.co.jp>

Head Office: Tokyo; Tel. 81-3-3360-5121. Fax 81-3-3365-8605
 Beijing Office: Tel., Fax. 86-10-6525-3601. Tel. 86-10-6513-3516
 Overseas Branch Offices: Seoul. Singapore. Taipei

● Transmitter

Item		Description
Model		CT9401 (sophisticated model)
Rangeability	Flowrate	See general performance table.
	Temperature	-200 ~ +200°C (explosionproof ; -20 ~ +165°C)
Power supply		85 ~ 264VAC 50/60Hz or 20 ~ 30VDC
Power consumption		Max. 25VA or Max. 10W
Ambient temperature		-20 ~ +50°C
Transmission length (separate type)		Max. 200m (Exclusive cable used)
Explosionproof construction		Combined explosionproof Exd (ib)IIBT3 or Exd (ib)IIBT4
Dust and waterproof construction		IP66
Mounting		Integrally or separately-mounted
Display		8-digit (7-segment) LDC display
Mass		4.6kg approx. (5.8kg approx., separate type)
Communication interface		HART protocol and Bell 202
Status input		Remote zero (std.) or optional feature/contact-closure input (From "a" contact)
Pulse output		Open collector output (10V min.~30Vmax.,50mA DC) or, voltage pulse "0": 1.5V max., "1": 15V, Output impedance 2.2kΩ , FS:0.1~10000Hz
Analog output		4~20mADC (max. load 600Ω) Two outputs from instantaneous flowrate (mass, volume) temperature or density. Additional damping: 0~200sec.
Status output		Open collector output (Normal: ON; Abnormal : OFF) Select one from error, flow direction, Hi/Lo alarm.
Drive control voltage output		DC voltage output (for checking)

■ GENERAL PERFORMANCE

Item		Description		
Model		CN010H (G)	CN015H (G)	
Flowrate	Normal flowrate	14 kg/min	42.5 kg/min	
	Allowable flowrate	28 kg/min	85 kg/min	
	Min. FS flowrate	2 kg/min	6.5 kg/min	
	Guaranteed lowest flowrate	0.4 kg/min	1.3 kg/min	
	Accuracy in factory calibration	Liquids	[±0.2% ± zero stability error] of RD Normal flowrate over [±0.3% ± zero stability error] of RD	
		Gases	[±0.5% ± zero stability error] of RD	
	Zero stability	0.0035 kg/min	0.0106 kg/min	
Density (Liquids)	Measuring range	0.3 ~ 2 g/mL		
	Accuracy in factory calibration (option)	±0.004 g/mL		

$$\text{Zero stability error} = \frac{\text{Zero stability (kg/min)}}{\text{Flowrate at that time (kg/min)}} \times 100\%$$

Note 1: For volume flowrate measurement in custom or custody transfer application, contact us.

Note 2: In gas measurement, the max. permissible flow velocity varies with the type of gas and some may be beyond the bounds of measurement. If such is the case, seek our technical assistance.

■ DISPLAY

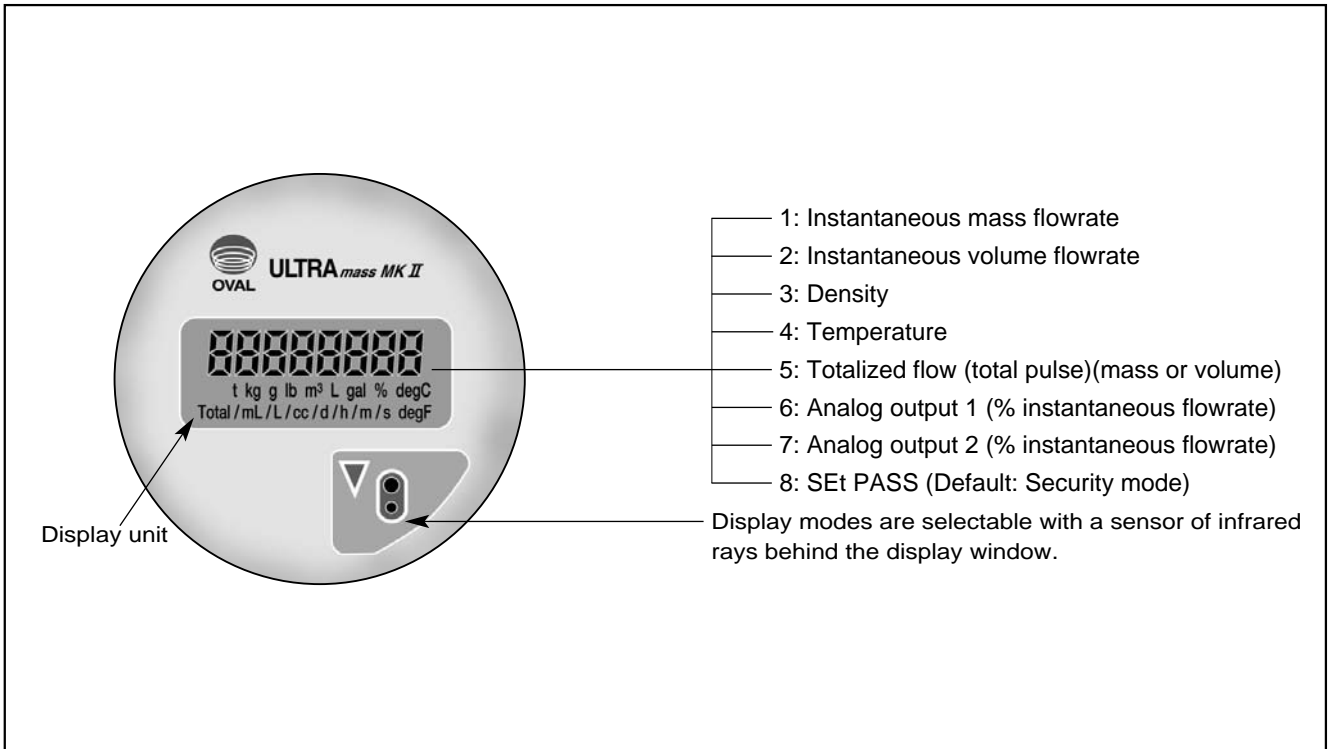

■ METER ERROR

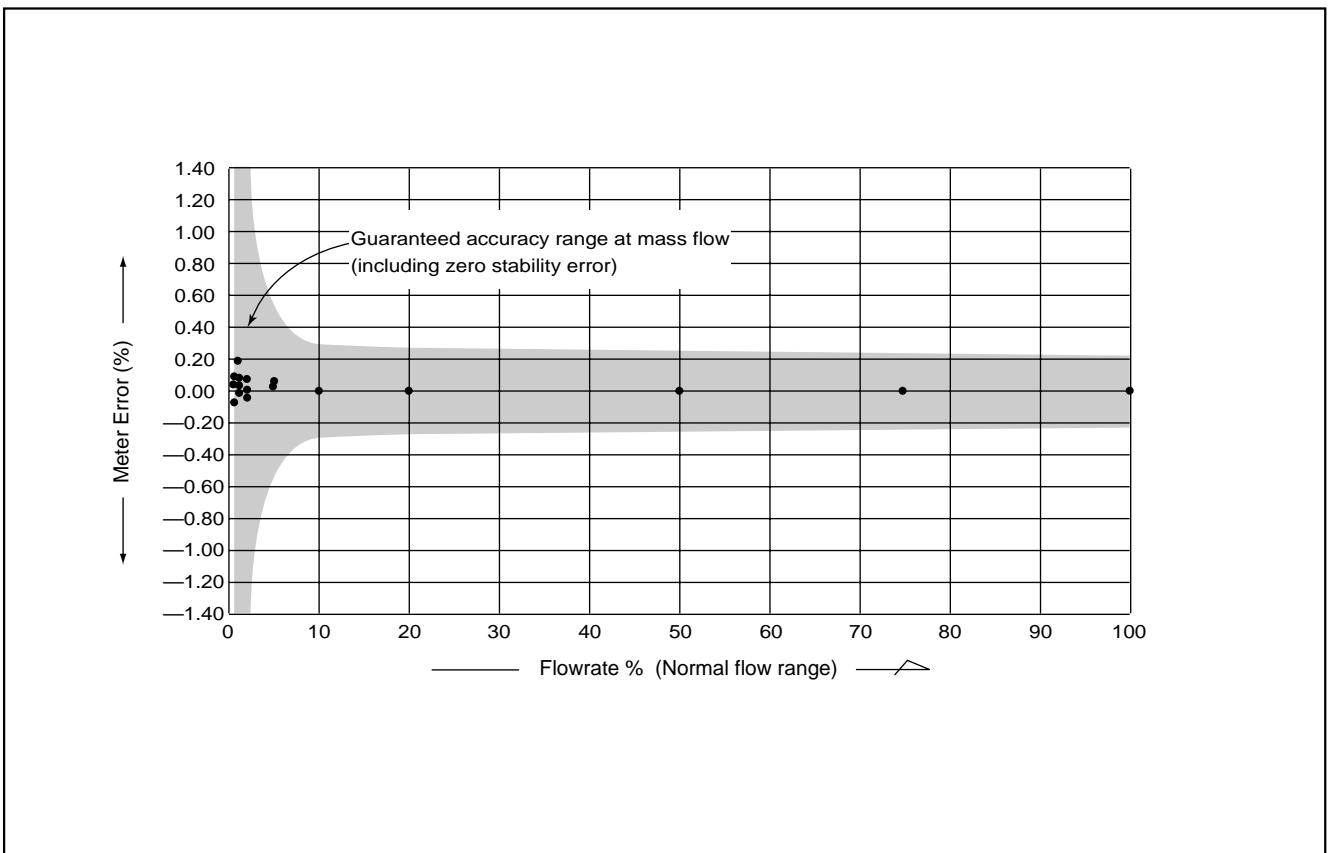

■ ALLOWABLE PRESSURE-TEMP. DERATING CURVES

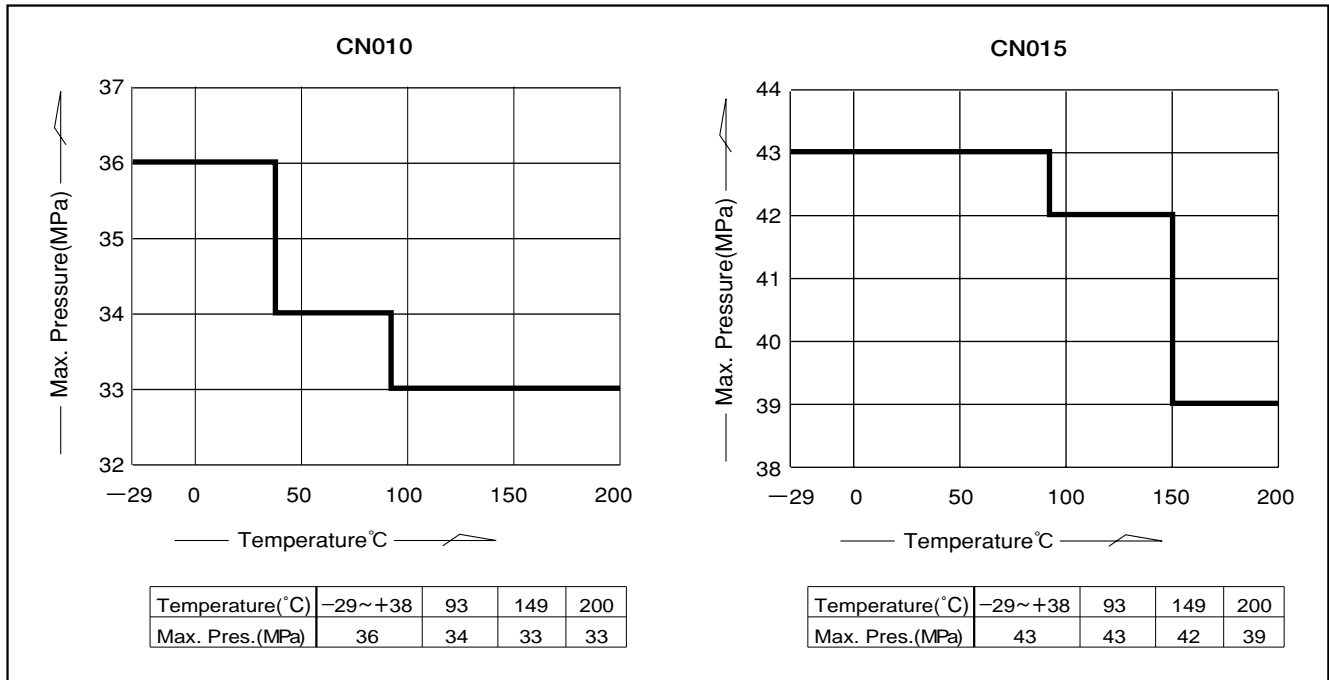

■ PRESSURE LOSSES

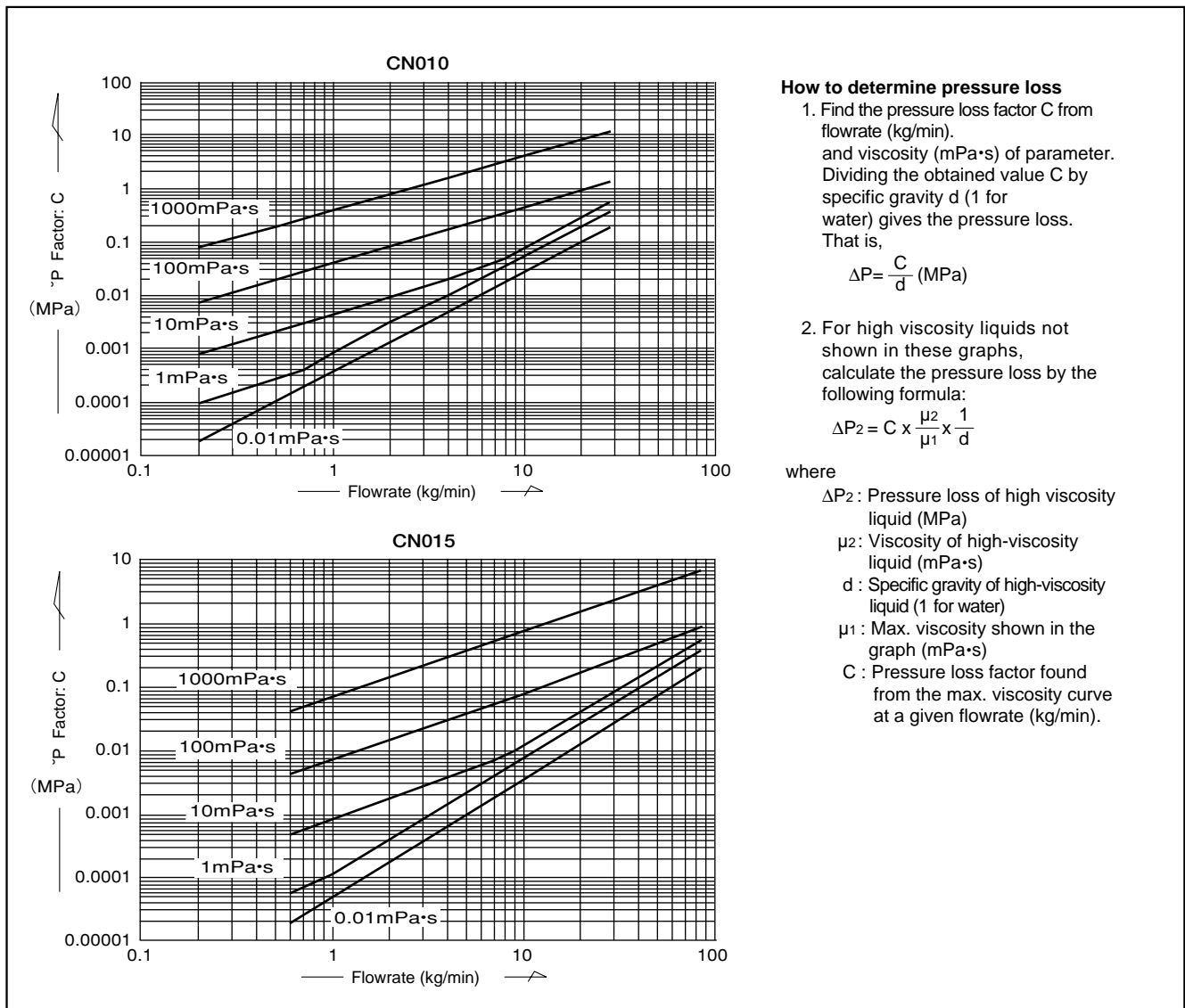

OUTLINE DIMENSIONS [Unit in mm]

Transmitter Integral Type

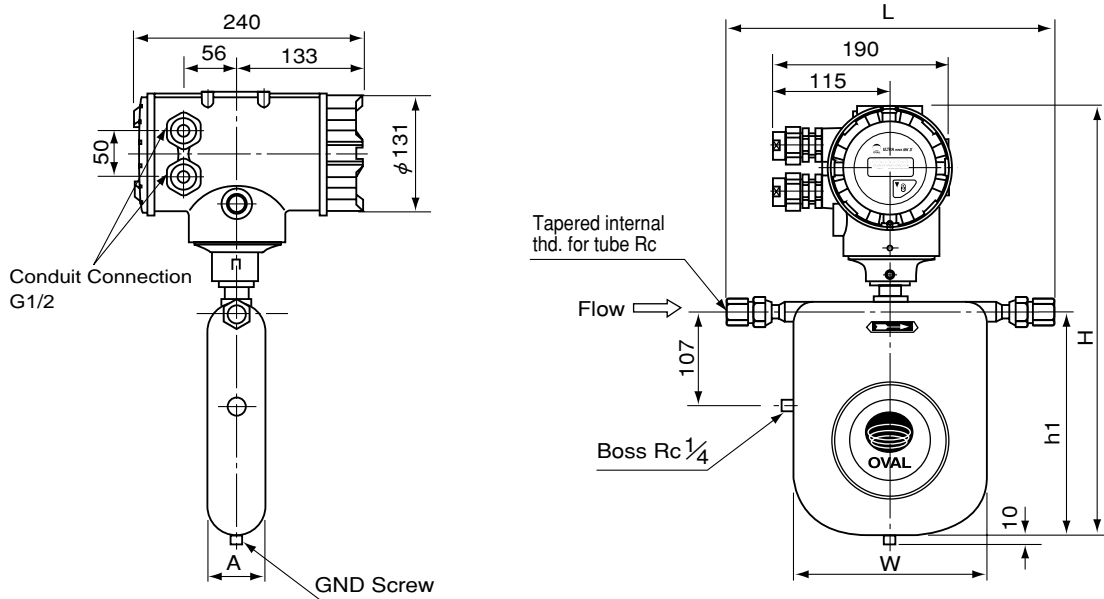

Model	Screw	L	H	h1	A	W	Approx. Mass kg
	Connection						
CN010	Rc 3/8	312	461	218	53	163	7.3
CN015	Rc 3/4	382	511	268	65	205	8.1

Transmitter Separate Type w/ferrule connection

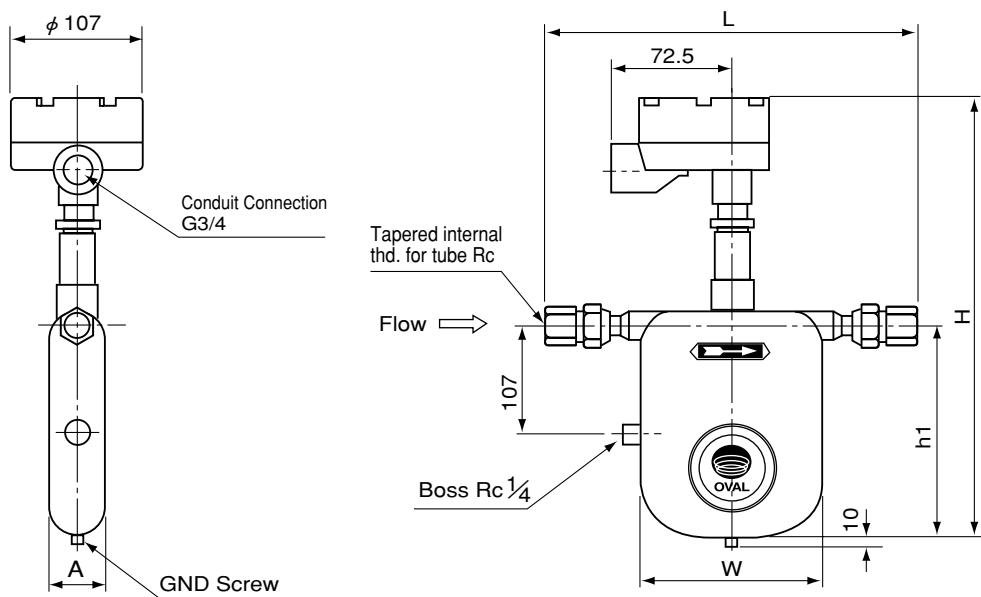

Model	Screw	L	H	h1	A	W	Approx. Mass kg
	Connection						
CN010	Rc 3/8	312	406	218	53	163	3.4
CN015	Rc 3/4	382	456	268	65	205	4.2

■ **OUTLINE DIMENSIONS** [Unit in mm]

Local mount type Transmitter (CT9401)

- **Stanchion type (Pipe support)**

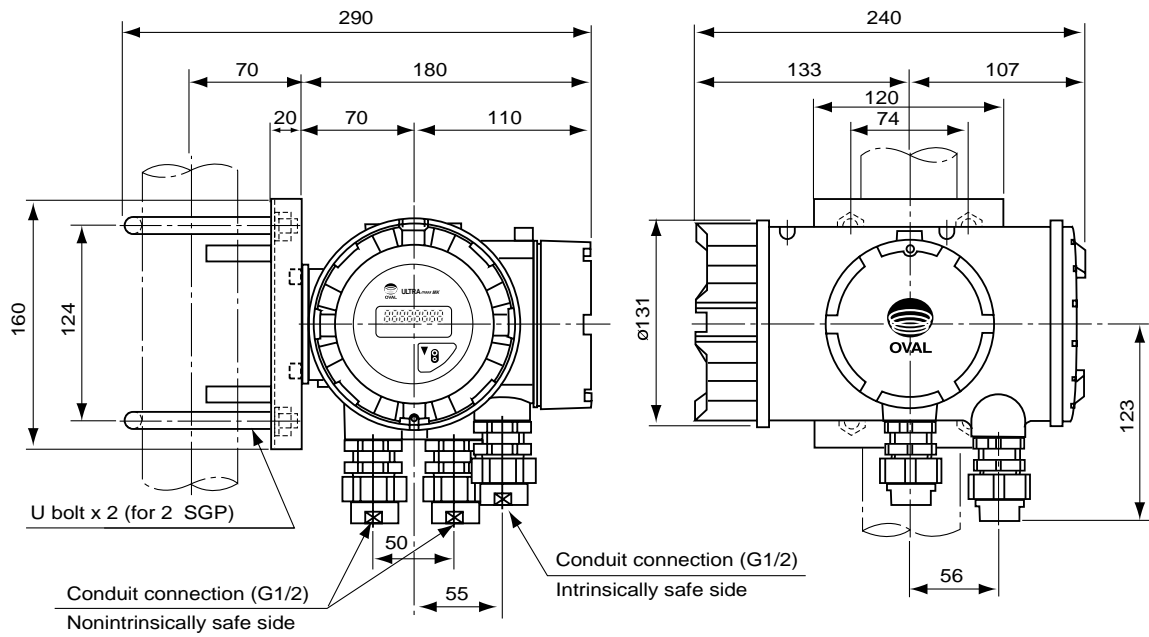

■ REMOTE MEASURING SYSTEM

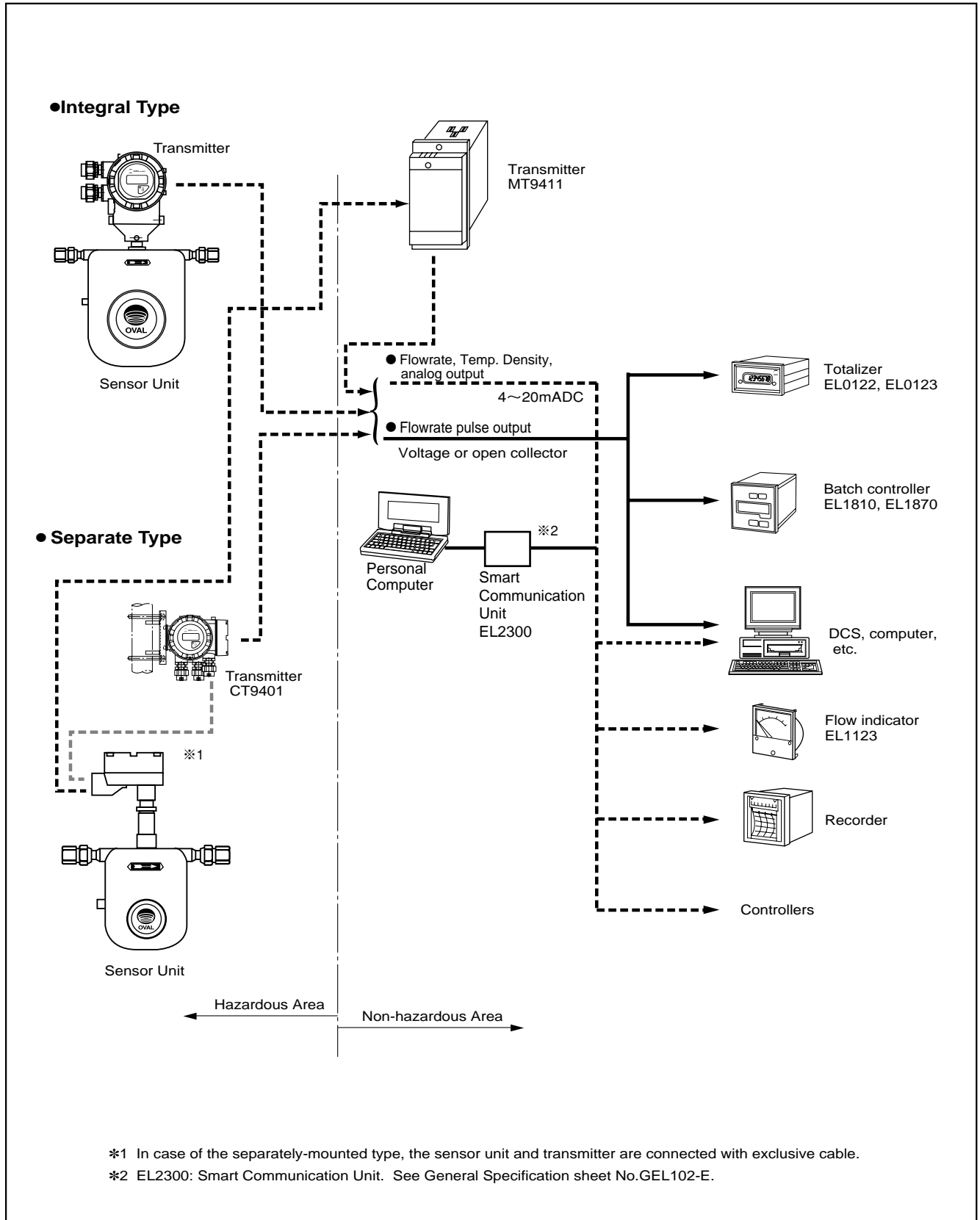

■ WIRING for CT9401

● Transmitter Integral Type

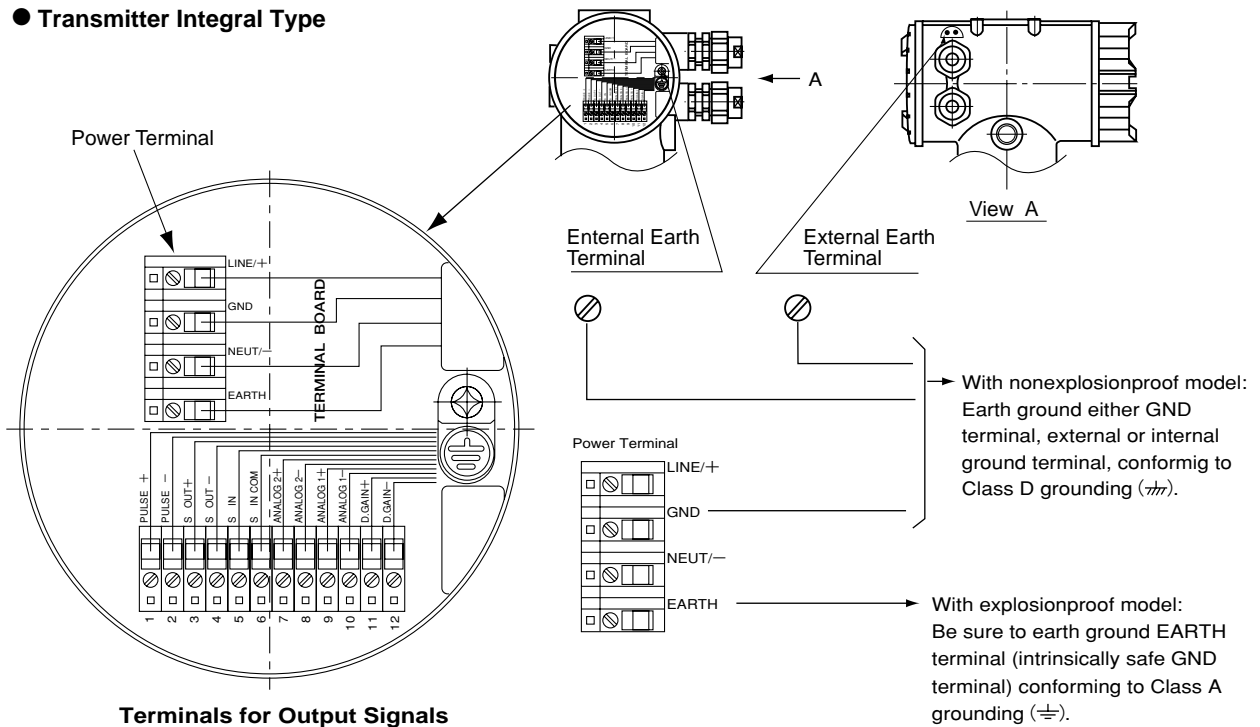

Terminals for Output Signals

● Remote Output Signal Connection Terminals

Item	Terminal No.	Label	Description	Remarks
Output Signal	1	PULSE +	Pulse output	1. Use shielded twisted pairs AWG24-16 for output wiring. 2. Max. load resistance is 600Ω for analog outputs 1 and 2. 3. Pulse output (voltage pulse) transmission length is Max. 10m (at 10kHz) Max. 100m (at 1kHz) Max. 1km (at 100Hz)
	2	PULSE -		
	3	S OUT +	Status output, Open collector output	
	4	S OUT -	Normal: ON; Abnormal: OFF	
	5	S IN	Status input (Form "a" contact input)	
	6	S IN COM		
	7	ANALOG2+	Analogue output 2	
	8	ANALOG2-	Analogue output 1	
	9	ANALOG1+		
	10	ANALOG1-		
Power		LINE/+	Power (with DC power: +)	A-Grade earth grounding Be sure to earth ground at GND or EARTH terminal.
		GND	Earth ground	
		NEUT/-	Power (with DC power: -)	
		EARTH	Class "A" earth ground work	

● Terminal Identification between Separate type Sensor Unit and Transmitter

Item	Terminal No. (Cable color)	Label	Description	Remarks
Sensor to Transmitter	Black	SHIELD	Bundle BWN/RED, GRN/WHY, BLU/GRY, ORG/PUR/YEL shield wires.	Dedicated interconnect cable is used. Transmission length 200 meters max.
	Brown	(+) DRIVE	Flow tube drive output	
	Red	(-) DRIVE		
	Orange	TEMP B	Temperature input	
	Yellow	TEMP b	Temperature input	
	Green	(+) LPO	Left position pickoff input	
	Blue	(+) RPO	Right position pickoff input	
	Purple	TEMP A	Temperature input	
	Grey	(-) RPO	Left position pickoff input	
White	(-) LPO	Right position pickoff input		

■ WIRING for CT9401

● Transmitter Separate Type

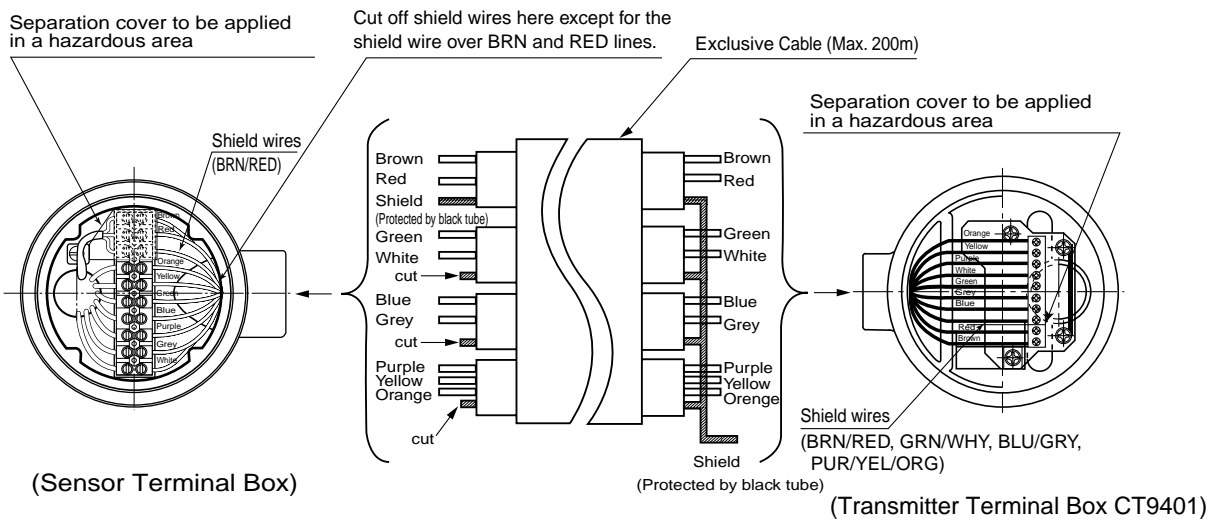
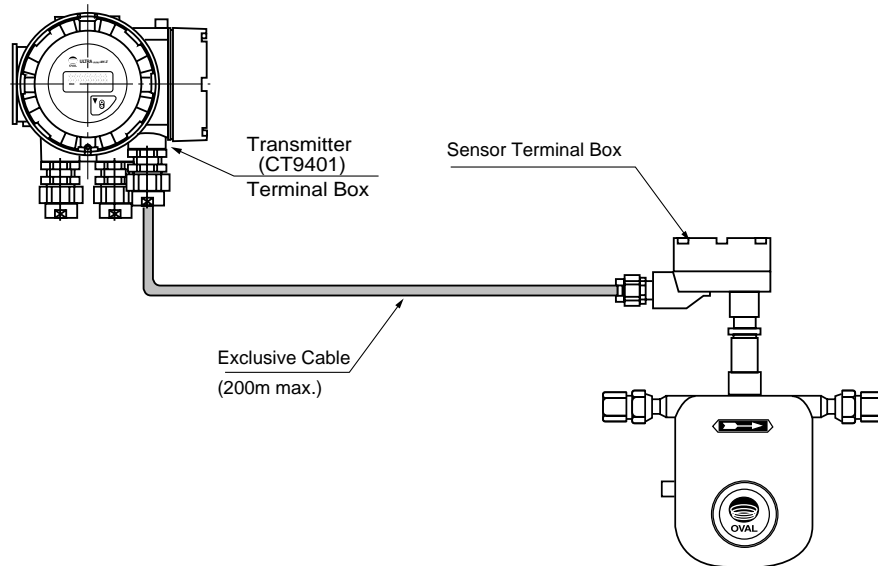

NOTES 1. Do not fail to use exclusive cable.

2. Shield wire preparation

(1) Transmitter end:

Bundle the shield wires corresponding with brown/red, green/white, blue/grey, purple/orange/yellow and slip a black sleeve over them as shown in the figure, exercising care to avoid potential contact with the housing and other conductive parts.

(2) Sensor end:

Slip a black sleeve over the shield wires corresponding with brown/red pair cable as shown in the figure, exercising care to avoid potential contact with the housing and other conductive parts. Clip all other shield wires.

How to install the cover. After wiring with the relay terminals, install the cover as shown below.

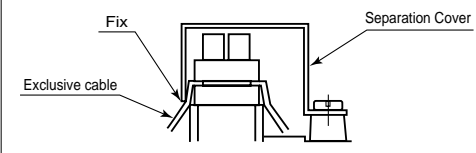

■ STANDARD INSTALLATION

1. Typical Installation (See figure at right.)

- 1) Avoid pipeline stresses on the ULTRAss MKII.
- 3) The ULTRAss MKII should be supported near its connections to the process pipelines.
- 3) Avoid supporting the ULTRAss MKII body directly.
- 4) Pipeline should be arranged such that the ULTRAss MKII is constantly filled with the process fluid. Avoid, however, to install it in a pocket where slurries may build up.
- 5) Provide a valve downstream of the meter to allow zeroing by obtaining a true zero flow. We recommend to provide another valve upstream of the meter for servicing or maintenance.

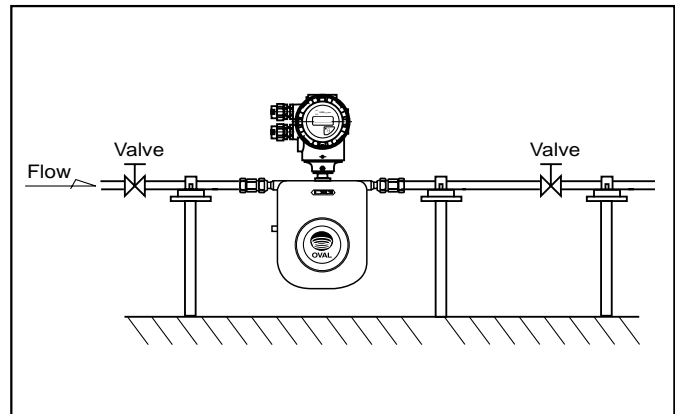

2. Precautions at Installation

- 1) Locate the ULTRAss MKII at least one meter from large transformers, motors, or other sources of electromagnetic induction. Also avoid installation near the sources of excessive vibration, such as motors and pumps.
- 2) If it is desired to make a measurement of a process fluid requiring heat retention, heat trace may be applied directly to the sensor body. Heat trace should be held below 200°C. Explosionproof models require the temperature to be held below their maximum allowable levels.
- 3) In density measurement, heat retention is suggested for stability of readings.
- 4) The sensor unit is of gastight construction. To prevent dew condensation inside in a low temperature application, it is filled with argon gas. For this reason, avoid dropping or giving it impact shocks.
- 5) In a horizontal run, install the sensor unit with the transmitter up as shown in the figure.
- 6) A control valve should be located downstream of the ULTRAss MK II. In an arrangement where cavitation may possibly take place, locate it at least 5 meters away.
- 7) To ensure precise and consistent measurement, a coriolis flowmeter with integrally mounted transmitter should be installed in an environment where pipeline oscillation is held below 0.3G.

3. Physical Orientation

Recommended physical orientation varies with the type of process fluid. No. 2 in the figure below shows the representative orientation for liquid service.

		Horizontal Run		Vertical Run
No.	1	2	3	
Orientation				
Fluids	<ul style="list-style-type: none"> ● Gases ● Slurries 	<ul style="list-style-type: none"> ● Liquids 	<ul style="list-style-type: none"> ● Slurries (requiring cleaning) ● Liquids ● Gases 	

NOTE: Do not forget to specify the physical orientation when you order.

■ PRODUCT CODE EXPLANATION

● Sensor Unit

Item	Code No.												Description
	①	②	③	④	⑤	⑥	⑦	⑧	⑨	⑩	⑪	⑫	
Model	C	N											ULTRA mass MK II
Nominal size	0	1	0										Rc $\frac{3}{8}$ "
	0	1	5										Rc $\frac{3}{4}$ "
Construction	G	-											High Pressure Type (High Temperature service)
	H	-											High Pressure Type
Material						H	Y	-					Flow tube : Hastelloy-C22, Manifold : Equivalent Hastelloy (CX2MW)
Connection type									2				Screw connection
Connection standard										0			Always "0"
Pressure rating											0		Always "0"
Transmitter Mounting Construction												K	Integrate type CT9401 (Temperature range Max.120°C)
												R	Separately-mounted type CT9401 or rack-mount transmitter MT9411

NOTES 1.: Structural codes H apply to fluid and atmospheric temperatures below 130°C.

2.: Structural codes G (high temp. service) apply to fluid and atmospheric temperatures above 130°C.

● Local mount Transmitter (CT9401)

Item	Code No.												Description	
	①	②	③	④	⑤	⑥	⑦	⑧	⑨	⑩	⑪	⑫		
Model	C	T	9	4	0	1	-						Local mount transmitter (CT9401)	
Construction												K	Integrally-mounted type	
												R	Separately-mounted type	
Power supply											6		20 ~ 30VDC	
											7		85 ~ 264VAC 50/60Hz	
Analog output (NOTE 1)												M	M	Mass flow rate Analog 2 output
												M	D	Mass flow + Density
												M	T	Mass flow + Temperature
												M	V	Mass flow + Volume flow
												D	T	Density + Temperature
												V	D	Volume flow + Density
												V	T	Volume flow + Temperature
												M	X	Mass flow rate 1 output (voltage pulse output)
Pulse output												D	X	Density 1 output (voltage pulse output)
												V	X	Volume flow 1 output (voltage pulse output)
											1		Mass flow voltage pulse (option)	
											2		Volume flow voltage pulse (option)	
Explosion-proof (NOTE 2)												3		Mass flow open collector pulse
												4		Volume flow open collector pulse
											0		Nonexplosionproof	
											1		TIIS (temp. grade T3)	
											2			
											3		TIIS (temp. grade T4)	

NOTE 1.: If voltage pulse output is chosen for pulse output, the analog output 2 is not available; select "X" in model code place (10).

NOTE 2.: Temp. grade T4 for integrally-mounting types only.

■ PLEASE SUPPLY THE FOLLOWING INFORMATION WHEN YOU INQUIRE

1. Process fluid *1	Name _____ SP. gr. _____ Viscosity _____ Slurry content in a slug flow _____ %	
2. Flow range	Max. _____ Normal _____ Full scale _____ <input type="checkbox"/> kg/min <input type="checkbox"/> kg/h	
3. Fluid temperature	Max. _____ °C Normal _____ °C Min. _____ °C	
4. Operating pressure	Max. _____ MPa Normal _____ MPa Min. _____ MPa	
5. Ambient temperature	Max. _____ °C Min. _____ °C	
6. Fluid flow direction	<input type="checkbox"/> Left → Right <input type="checkbox"/> Right → Left <input type="checkbox"/> Bottom → Top (<input type="checkbox"/> Top → Bottom)	
7. Required accuracy	± _____ % of reading ± _____ % of full scale	
8. Explosion-proof	<input type="checkbox"/> Required <input type="checkbox"/> Not required	
9. Power supply	Power _____ V <input type="checkbox"/> AC <input type="checkbox"/> DC	
10. Output specifications	Pulse output	<input type="checkbox"/> Volt. pulse: [0]: 1.5V [1]: 15VDC min. Out. impedance: 2.2kΩ
		<input type="checkbox"/> Open collector: Min. 10V ~ Max. 30VDC, 50mA
		<input type="checkbox"/> Output frequency: Any point from 0.1 ~ 10000Hz at full scale
	Analog output	4 ~ 20mA DC Max. load: 600Ω
		2 outputs from instant. flow rate (mass, volume), temp. or density (option)
	Additional damping	0 ~ 200s. (variable)
Alarm output	Slug flow *2 High _____ g/mL Low _____ g/mL	
11. Companion receiver	<input type="checkbox"/> Totalizer <input type="checkbox"/> Indicator <input type="checkbox"/> Recorder <input type="checkbox"/> Flow controller <input type="checkbox"/> Batch controller	
	<input type="checkbox"/> Computer <input type="checkbox"/> Others	
12. Transmission length	Sensor unit (<input type="text"/>) m Transmitter (<input type="text"/>) m Receiving instrument	
13. Exclusive cable length	In case of separately- mounted type _____ m (Max. 200m)	
14. In case of a separated type transmitter	<input type="checkbox"/> Stanchion type w/bracket and 2" U bolts	
15. No. of units required		
16. Application		
17 Other considerations		

*1: Special fluids, such as high viscosity fluids and slurries, should be stated precisely and in detail.

*2: Option

The specification as of July, 2007 is stated in this GS Sheet. Specifications and design are subject to change without notice.



Sales Representative:
icenta CONTROLS Ltd
North Station Yard, Warminster Road, Wilton, Salisbury, SP2 0AT
Tel: 0845 895 1020 Fax: 0845 895 1021
Email: sales@icenta.co.uk
www.icenta.co.uk