

# Wiring Information: Instruments

## III. Rear Terminal Views +GF+ SIGNET Flow Instruments

### Wiring Information

- The terminal blocks for the 8550 are not labeled on the back of the unit. An adhesive label is supplied with the instruments with terminal descriptions to serve as a remote terminal display to aid electrical installations.
- The 8150 Battery Powered Flow Totalizer is compatible only with the AC output sensors, 515, 525 and 2517. The wiring is shown here. See Operation Manual for more information.

Terminal 8550-1

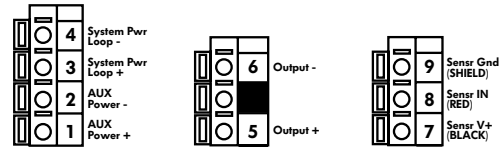

Terminal 8550-2

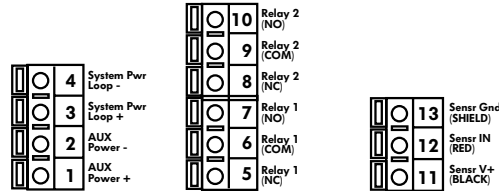

Terminal 8550-3

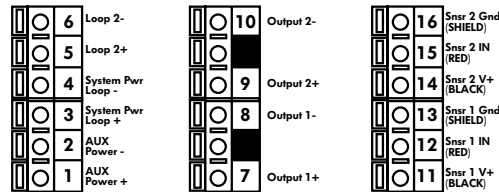

5075

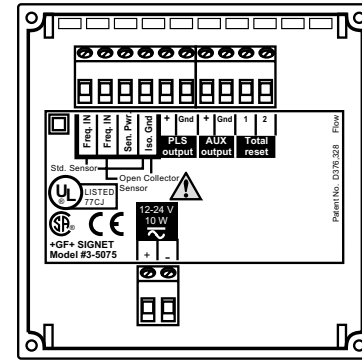

5090

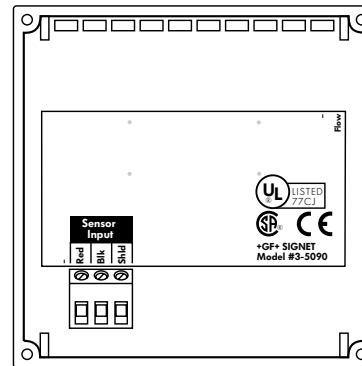

5091

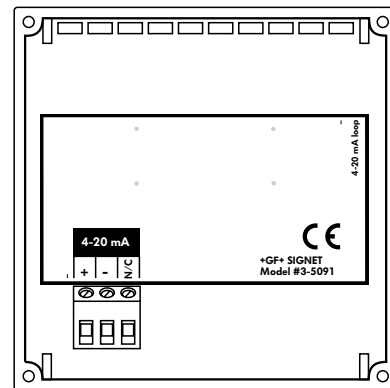

5500

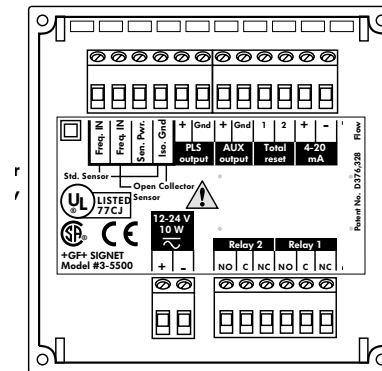

5600

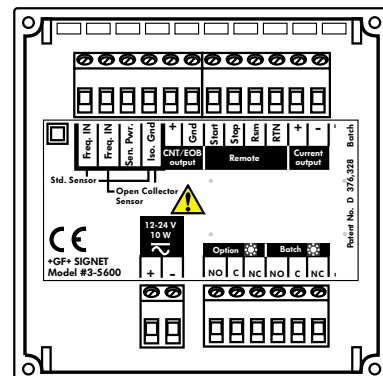

8150 Battery Powered Flow Totalizer

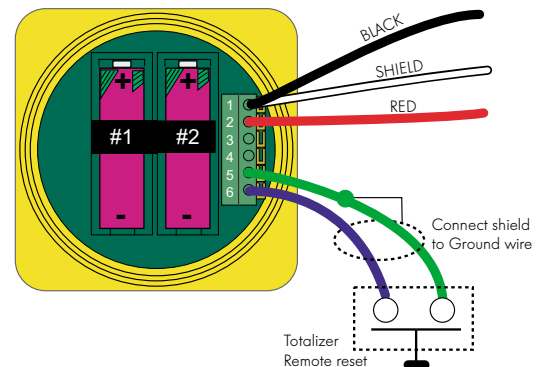



# Wiring Information: Instruments

## III. Rear Terminal Views +GF+ SIGNET Analytical Instruments

### Temperature

Terminal 8350-1

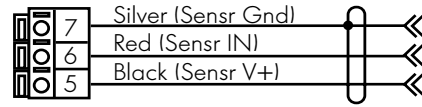

Terminal 8350-2

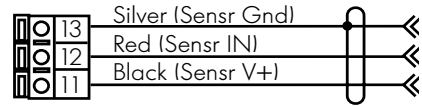

Terminal 8350-3

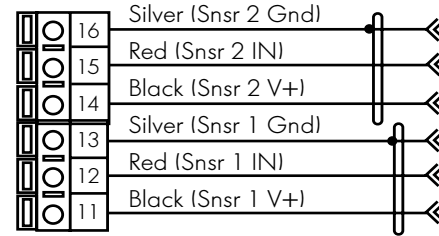

### Level

Terminal 8250-2

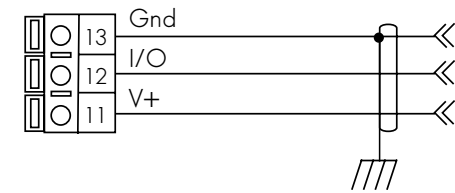

The TOTAL cable length connected to the 8250 input/output terminals must not exceed 122 m (400 ft.)

Terminal 8250-3

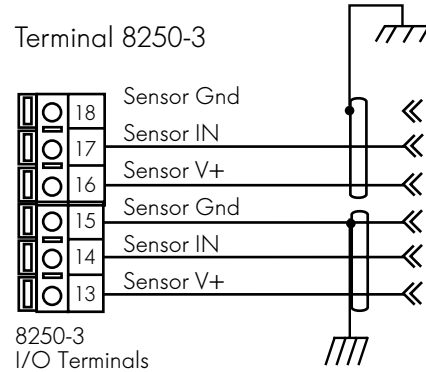

8250-3  
I/O Terminals

### Pressure

Terminal 8450-1

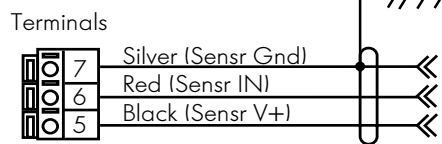

Terminal 8450-2

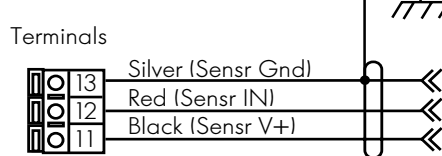

Terminal 8450-3

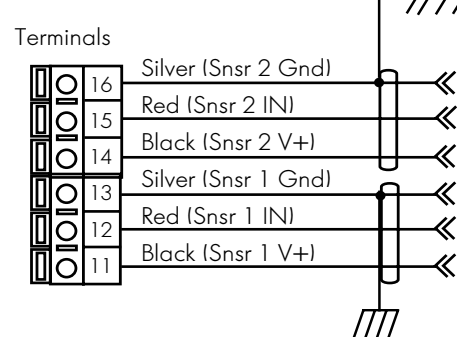

# Wiring Information: Instruments

## III. Rear Terminal Views +GF+ SIGNET Instruments

### 8900 Multi-Parameter

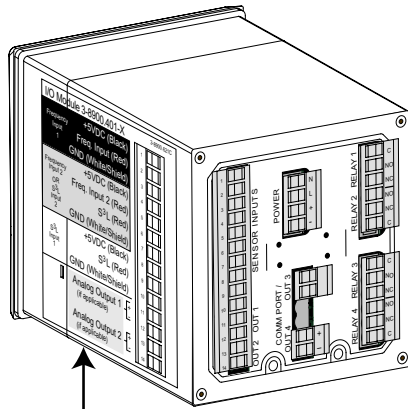

**Power Connection** ⚠

100 - 240VAC ~  
50-60Hz, 24VA MAX

11 - 24 VDC ---  
0.7 A MAX.

**CAUTION**

DO NOT attempt to connect both AC and DC at the same time

3-8900.620

**Mechanical Relays**

Rating:  
5A 250 VAC ~  
5A 30 VDC ---

⚠

**Solid State Relays**

Rating:  
50 mA 30V ~

**I/O Module 3-8900.401-X** 3-8900.621C

Frequency Input 1	+5VDC (Black)	1
	Freq. Input (Red)	2
	GND (Shield)	3
Frequency Input 2	+5VDC (Black)	4
OR	Freq. Input 2 (Red)	5
S <sup>3</sup> L Input 2	S <sup>3</sup> L (Red)	6
	GND (White/Shield)	7
S <sup>3</sup> L Input 1	+5VDC (Black)	8
	S <sup>3</sup> L (Red)	9
	GND (White/Shield)	10
Analog Output 1 (if applicable)		11
Analog Output 2 (if applicable)		12
		13
		14

### Maximum Cable Lengths for all sensors used with the 8900

The I/O Module (3-8900.401-x) supports frequency and S<sup>3</sup>L signal types. These signal types are fundamentally different from one another, and the rules governing maximum cable lengths also differ, so the two types must be treated separately. Refer to the following two sections as necessary to determine the cable length limitations of any system.

### Signal Type: Frequency

The maximum allowable cable length for flow sensors with frequency output is dependent upon the output signal strength of the sensors themselves, and the degree to which the signals are susceptible to EMI or "noise". This is largely a function of whether the sensors are self-powered, or powered by an external source.

All of the sensors in the table below are compatible with the 8900. The three models limited to 60 m (200 ft.) are self-powered sensors. The 8900 automatically provides power to the others via the I/O Module (normal sensor wiring).

These maximum recommended cable lengths apply to individual sensors and are completely independent of one another. Additionally, these cable lengths have no relevance to any digital (S<sup>3</sup>L) devices that may also be connected to the I/O Module.

+GF+ SIGNET Flow sensor models with frequency output												
Maximum cable length	515	525	2000	2100	2507	2517	2536	2540	2541	2550	7000	7002
60 m (200 ft.)	X	X				X						
305 m (1000 ft.)			X	X	X		X	X	X	X	X	X

### III. Rear Terminal Views +GF+ SIGNET Instruments

#### Multi-Parameter (continued)

#### Signal Type: Digital (S<sup>3</sup>L)

The total maximum allowable cable length for all digital (S<sup>3</sup>L) devices in a system is primarily dependent upon the connecting instrument, not the sensors or external relays themselves. From an instrument's EMI filtering

capability, and its capacity to provide power to these devices, maximum cable length guidelines can be established. For the 8900, these guidelines are defined here.

#### Maximum Total Lengths From The S<sup>3</sup>L-Device to the 8900

Wire Size			Total Current Consumption of S <sup>3</sup> L Device					
Wire Cross-section mm <sup>2</sup>	Diameter mm	â/m	1 mA	2 mA	4 mA	10 mA	20 mA	40 mA
0.20	0.505	0.089	560 m	500 m	280 m	140 m	50 m	20 m
0.25	0.564	0.071	700 m	700 m	350 m	170 m	70 m	30 m
0.50	0.798	0.035	900 m	1410	700 m	350 m	140 m	70 m
0.75	0.977	0.024	900 m	900 m	1050	520 m	210 m	100 m
1.00	1.128	0.018	900 m	900 m	1410	700 m	280 m	140 m
1.50	1.382	0.012	900 m	900 m	900 m	1050 m	420 m	210 m
2.50	1.784	0.007	900 m	900 m	900 m	1760 m	700 m	350 m
4.00	2.257	0.004	900 m	900 m	900 m	900 m	1120 m	560 m

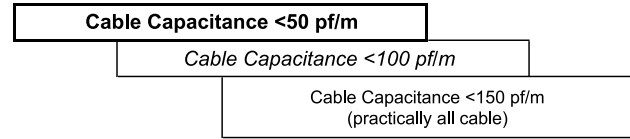

In order to use this table, the total maximum current consumption of all the digital (S<sup>3</sup>L) devices in the system must be known. Refer to the current consumption table and add the appropriate mA values to find the total. Round up to the nearest column heading in the cable length table, or extrapolate between columns to approximate the

maximum allowable cable length for all S<sup>3</sup>L devices in the system (regardless of topology). Notice the influence of wire size and capacitance on maximum allowable cable lengths. Proper cable selection is imperative, especially when long runs are required in an installation.

Installation & Wiring

Maximum Current Consumption for S <sup>3</sup> L Devices	
S3L Device	Current Consumption per Device
2350 Temperature Sensor	1 mA
2450 Pressure Sensor	1 mA
2750 and 2760 pH and ORP Sensors	3 mA
2850 Conductivity Sensor	2 mA
8059 External Relay Module *	1 mA

\* The S<sup>3</sup>L communication link between the 8900 and the 8059 is powered by the 8900 and consumes 1 mA maximum. However, the 8059 External Relay Module always requires a separate power source for its operation.

The Maximum Current table above applies only to digital (S<sup>3</sup>L) devices powered by the 8900 (normal sensor wiring). If an auxiliary power source more local to the sensor is

used, then wire size may be reduced and S<sup>3</sup>L wiring distances may be substantially increased. Contact your local +GF+ sales office for more information.