

Overview



MAG 8000 is a battery powered electromagnetic water meter designed according to the global water meter standard OIML R49 and the European CEN EN 14154. The meter fulfills the special customer demands to water applications within abstraction, distribution network, revenue metering as well as irrigation. All functionalities integrated in one meter to optimize water supply and use of highly scanty resources.

MAG 8000 is a comprehensive meter which intelligent information and high performance measurement as well as the easy to install concept take cost of ownership and customer service to a new level for water meter.

Features like 6 years maintenance-free battery-powered operation and no moving parts provide long-term accuracy measurement.

Benefits

Easy to install

- Compact or remote solution with factory mounted cable
- IP68/NEMA 6P enclosure. Sensor can be buried
- Flexible power supply - internal or external battery pack or mains power supply with battery back-up possibilities

Superior measurement

- Down to 0.2% maximum uncertainty
- OIML R49 type approval
- Bi-directional measurement

Long lasting performance/Cost of Ownership

- Verification according to Directive 2004/22/EC of the European Parliament and Council of March 31, 2004 on measuring instruments (MID), Annex MI-001
- No moving parts means less wear and tear
- 6 years operation in typical revenue application
- Robust construction build for the application

Intelligent information, easy to access

- Advanced information on site
- Data logger for consumption profile
- Advanced statistics and diagnostics
- Add-on communication module

Application

MAG 8000 has been developed as a stand alone water meter for applications within:

- Abstraction
- Distribution network (from treatment plant to customer)
- Revenue metering (measuring water delivered for billing purpose)
- Irrigation (measuring water delivered for billing purpose and water consumption)

Design

MAG 8000 is designed according to OIML R49 and CEN EN 14154 water meter standards with focus on minimized power consumption.

The product program consists of

- Basic version: For general water applications
- Advanced version: With advanced information and functionality.
- A Custody Transfer version for water billing, with type approval after OIML R49 and verified according to MI-001 for DN 50 to DN 300
- Sensor sizes from DN 25 to 1200 (1" to 48")
- Compact and remote installation in IP68/NEMA 6P enclosure and factory mounted cable
- Flexible power supply; internal or external battery pack or mains power supply with battery back-up possibilities
- Add-on communication modules
- PC configuration SIMATIC PDM and Flow Tool PC configuration software
- Customer setting from factory

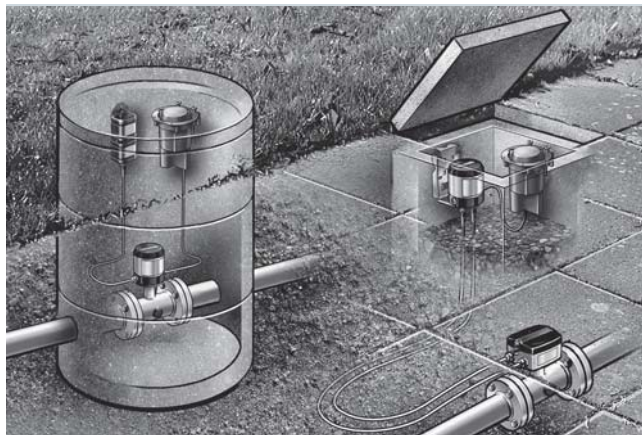

Add-on communication module (left), PC-IrDA connection (right)

Function

MAG 8000 is a microprocessor-based water meter with graphical display and key for optimum customer operation and information on site. The transmitter drives the magnetic field in the sensor, evaluates the flow signal from the sensor and calculates the volume passing through. It delivers the required information via the integrated pulse output or communication interfaces as part of a system solution. Its intelligent functionality, information and diagnostics ensure optimum meter performance and information to optimize water supply and billing.



MAG 8000 can be ordered as a Basic or an Advanced version. The Basic version is selected for general water applications whereas the Advanced version is for more advanced functionality and information. Both versions are configured to achieve 6 years battery operation in typical revenue applications.

MAG 8000 CT is identical to the Basic and the Advanced versions. Only difference is that revenue parameters and data are protected against manipulation. The Custody Transfer version also includes additional labels, verification and user sealings to verify the CT meter according to MID.

Some information is accessible via the display whereas all information is accessible via the IrDA and communication interface with the PC Flow Tool or PDM software. Data and parameters are registered in a EEPROM. They can all be read, but changing the information demands a software password or a hardware key attached to the printed circuit board.

Features / Version	MAG 8000 Basic	MAG 8000 Advanced
Measuring frequency in battery power mode (Manually selected)	1/15, 1/30 or 1/60 Hz	from 6.25 to 1/60 Hz depending of sensor size
Output MAG 8000	2 FW/RV/AI/CA (max. 50 Hz pulse rate)	2 FW/RV/AI/CA (max. 100 Hz pulse rate)
Output MAG 8000 CT	2 FW/AI (max. 50 Hz pulse rate)	2 FW/AI (max. 100 Hz pulse rate)
Communication	Add-on	Add-on
Data logger	Yes	Yes
Insulation test	-	Yes
Leakage detection	-	Yes
Meter utilization	-	Yes
Statistics	-	Yes
Tariff	-	Yes
Settle date (Revenue)	-	Yes

Technical specifications

Meter

Accuracy MAG 8000

- Standard calibration $\pm 0.4\%$ of rate $\pm 2\text{mm/s}$
- Extended calibration (2" ... 12"): $\pm 0.2\%$ of rate $\pm 2\text{mm/s}$
dimensions DN 50 ... DN 300

Accuracy MAG 8000 CT

- Custody transfer
 - OIML R49 for DN 50 ... DN 300, Class 1 and 2 with turn down up to Q3/Q1 = 400 at Q2/Q1 = 1.6
 - MI-001 verification for DN 50 ... DN 300, Class 2 with turn down ratio Q3/Q1 = 80, Q3/Q1 = 63 or Q3/Q1 = 25 at Q2/Q1 = 6.3

Media conductivity

Clean water > 20 $\mu\text{s/cm}$

Temperature MAG 8000

- Ambient -20 ... +60 °C (-4 ... +140 °F)
- Media 0 ... 70 °C (32 ... 158 °F)
- Storage -40 ... +70 °C (-22 ... +158 °F)

Temperature MAG 8000 CT

- Ambient -20 ... +60 °C (-4 ... +140 °F)
- Media 0.1 ... 30 °C (32 ... 70 °F)
- Storage -40 ... +70 °C (-22 ... +158 °F)

Enclosure

- IP68/NEMA 6P rating; Cable glands mounted requires Sylgard potting kit to remain IP68/NEMA 6P, otherwise IP67/NEMA 4 rating is obtained; Factory mounted cable provides IP68/NEMA 6P rating

Approvals MAG 8000

Drinking water approval

- NSF 61 (cold water) USA,
- WRAS (BS 6920 cold water) UK,
- ACS Listed France,
- DVGW W270 Germany,
- Belaqua (B)
- OIML R49 pattern approval

Approvals MAG 8000 CT

Drinking water approval

- NSF 61 (cold water) USA,
- WRAS (BS 6920 cold water) UK,
- ACS Listed France,
- DVGW W270 Germany,
- Belaqua (B)
- OIML R49 pattern approval
- MI-001 approval (Number: DK-0200-MI-001-002)

Conformity

- CEN EN 14154, ISO 4064
- PED: 97/23EC
- EMC: EN 61000-6-3, EN 61000-6-2, EN 61326-1

Sensor

Size, flange and pressure range MAG 8000

- EN 1092-1 (DIN 2501)
 - DN 25 and DN 40: PN 40
 - DN 50 ... 150: PN 16
 - DN 200 ... 1200: PN 10 or PN 16
- ANSI 16.5 Class 150 lb 1" ... 24": 20 bar (290 psi)
- AS 4087 DN 50 ... 1200: PN 16

Size, flange and pressure range MAG 8000 CT

- EN 1092-1 (DIN 2501)
 - DN 50 ... 300: PN 16
- ANSI 16.5 Class 150 lb 2" ... 12": 230 psi

Battery operated water meter MAG 8000/MAG 8000 CT

Sensor (continued)

- AS 4087

Max. excitation frequency
(Transmitter decide the selected
excitation frequency)

DN 50 ... 300: PN 16

- 6.25 Hz for sensor size
DN 25 ... 150 (1" ... 6")
- 3.125 Hz for sensor size
DN 200 ... 600 (9" ... 24")
- 1.5625 Hz for sensor size
DN 700 ... DN 1200 (28" ... 48")

Liner

EPDM

Electrode and grounding electrodes

Hastelloy C276

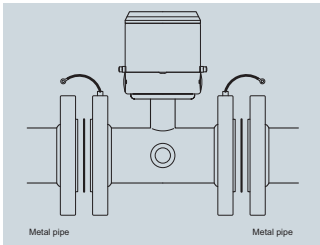

Grounding straps are pre-
mounted from the factory on each
side of the sensor.

Transmitter

Installation MAG 8000

Integral (compact) or remote with
factory mounted cable in 5, 10,
20 or 30 m lengths with
IP68/NEMA 6P connectors.
Connection is made at the trans-
mitter bottom.

Installation MAG 8000 CT

Integral (compact) or remote with
factory mounted cable in 5 or
10 m lengths with IP68/NEMA 6P
connectors.
Connection is made at the trans-
mitter bottom
MI-001 verified meters only Inte-
gral (compact) mounted.

Enclosure

Stainless steel top housing
(AISI 316) and coated brass bot-
tom. Remote wall mount bracket
in stainless steel (AISI 304).

Cable entries

2 x M20 (one gland for one cable
of size 6 ... 8 mm
(0.02 ... 0.026 ft) is included in the
standard delivery)

Display and key

- Display with 8 digits for main in-
formation. Index, menu and
status symbols for dedicated
information
- Key for toggling through the in-
formation and reset customer to-
talizer and call-up function
- Selectable default information
and accessible menus:
 - Operator
 - Meter
 - Service
 - Data Logger
 - Statistic and leakage (only
Advanced version)
 - Revenue and Tariffs (only
Advanced version)
- Totalized information can be dis-
played with 1, 2, 3 decimals or
automatic adjustment for maxi-
mum resolution

Flow unit MAG 8000

- Europe std.

Volume in m³ and flow rate in
m³/h

- US std.

Volume in Gallon and flow rate in
GPM

- Australian std.

Volume in MI and flow rate as MI/d

Other units selectable:

- Volume: m³ x 100, l x 100,
G x 100, G x 1000, MG,
CF x 100, CF x 1000, AF, Al, kl
- Flow: m³/min, m³/d, l/s, l/min,
GPS, GPH, GPD, MGD, CFS,
CFM, CFH
- Other units are ordered from fac-
tory or manually configured on-
site by sticking a label on the
display and changing the scal-
ing factors

Flow unit MAG 8000 CT

- Europe std.

Digital output MAG 8000

Volume in m³ and flow rate in
m³/h

- 2 passive outputs (MOS), indi-
vidual galvanically isolated
- Maximum load ± 35 V DC,
50 mA short circuit protected
- Output A function
Programmable as pulse volume
– forward – reverse – forward/net
– reverse/net
- Output B function
Programmable as pulse volume
(like output A), alarm or call-up

Digital output MAG 8000 CT

- Output
Max. pulse rate of 50 Hz (only
Basic version) and 100 Hz (only
Advanced version), pulse width
of 5, 10, 50, 100, 500 ms
- 2 passive outputs (MOS), indi-
vidual galvanically isolated
- Maximum load ± 35 V DC,
50 mA short circuit protected
- Output A function
Programmable as pulse volume
– forward
- Output B function
- Alarm
- Output
Max. pulse rate of 50 Hz (only
Basic version) and 100 Hz (only
Advanced version), pulse width
of 5, 10, 50, 100, 500 ms

Communication

IrDA: Standard integrated infrared
communication interface with
MODBUS RTU protocol

Add-on modules:

- RS 232 serial interface with
MODBUS RTU (Rx/Tx/GND),
point to point with max. 15 m ca-
ble
- RS 485 serial interface with
MODBUS RTU (+/-/GND), multi-
drop with up to 32 devices with
max. 1000 m cable

MODBUS RTU protocol is an
open protocol (further informa-
tion available on request)
Serial speed 1200, 2400, 4800,
9600, 19200, 38400 Baud

Power supply	<p>Auto detection of power source with display symbol for operation power.</p> <p>Internal battery pack: 2 D-Cell 3.6 V/33 Ah</p> <p>External battery pack: 4 D-Cell 3.6 V/66 Ah</p> <p>Mains Power supply:</p> <ul style="list-style-type: none"> • 12 ... 24 V AC/DC (10 ... 32 V) 2 VA • 115 ... 230 V AC (85 ... 264 V) 2 VA <p>Both mains power supply systems are upgradable for battery backup via internal D-Cell (3.6 V 16.5 Ah) or external battery pack. The power supply has 3 m (9.8 ft) power cable for external connection to mains supply.</p>
--------------	--

Features

Application Identification

Tag number (visible on display if numbers are selected) and meter location, up to 15 characters per information.

Time and date

Real time clock and date (max. 15 min. change per year)

Totalizer MAG 8000

- 2 totalizer: Forward, Reverse, Bidirectional netflow calculation and free selectable start value.
- 1 customer totalizer, following totalizer 1 setting and resettable via display key or software with logging of date and time.

Totalizer MAG 8000 CT

- 2 totalizer: Forward
- 1 customer totalizer, following totalizer 1 setting and resettable via display key or software with logging of date and time.

Measurement MAG 8000

- Free selectable volume and flow unit, where m^3 and m^3/h is default in display. All other units are displayed with a display label.
- Excitation frequency in battery operation (manually selected):
 - Basic, max. selectable excitation frequency of 1/15 Hz
 - Advanced, max. selectable excitation frequency of 6.25 Hz and sensor related
 - Default excitation frequency is selected for typically 6 years operation in a revenue application;
 - 1/15 Hz for DN 25 ... 150 (1" ... 6")
 - 1/30 Hz for DN 200 ... 600 (8" ... 24")
- Excitation frequency with mains power follow maximum sensor excitation frequency
- Filter constant is adjustable
- Low flow cut off, % of Q_n (Q3)
- Empty pipe detection (active symbol on display when active)
- Filter selection for mains power frequency (50/60 Hz)
- Correction factor for change flow direction or to adjust flow measurement

Measurement MAG 8000 CT

- Volume and flow unit, is m^3 and m^3/h as default in the display, if the meter has to obtain the MI-001 certification
- Excitation frequency in battery operation (manually selected):
 - Basic, max. selectable excitation frequency of 1/15 Hz
 - Advanced, max. selectable excitation frequency of 6.25 Hz and sensor related
 - Default excitation frequency is selected for typically 6 years operation in a revenue application;
 - 1/15 Hz for DN 25 ... 150 (1" ... 6")
 - 1/30 Hz for DN 200 ... 600 (8" ... 24")
 - 1/60 Hz for DN 700 ... 1200 (28" ... 48")
- Low flow cut off, % of Q_n (Q3)
- Empty pipe detection (active symbol on display when active)
- Filter selection for mains power frequency (50/60 Hz)

Data logger

- Logging of 26 records: selectable as daily, weekly or monthly logging
- Each logging includes:
 - Consumption on totalizer 1
 - Consumption on totalizer 2
 - Alarm in current period (13 alarms)
 - Meter status (8 values)
- Alarm on high or low consumption for selected logging period
- Totalizer 1 values for all 26 periods can be read on the display

Alarm

- Active alarm is indicated on the display
- Monitoring of all alarms with statistic recording on each alarm
 - Total hours an alarm has been active
 - Numbers of time the alarm has been activated
 - First time an alarm appears
 - Last time the alarm disappears
- Fatal faults is monitored before each measurement and interrupt the measurement, if active
 - Signal insulation – Flow signal immunity is influenced (only Advanced version)
 - Coil current – Fault in driving magnetic sensor field
 - Amplifier – Fault in signal circuit
 - Check sum – Fault in calculation or handling of data
- Warning faults
 - Low Power – customer selectable battery alarm level or power drop out
 - Flow overflow – Flow in sensor exceeds Q_{max} (Q_4) (125% Q_n (Q_3))
 - Pulse overflow on output A and B – Selected pulse volume is too small compared to actual flow rate and max. output pulse rate.
 - Consumption – saved data logger consumption exceeds customer selected limit on high or low consumption
 - Leakage – Leakage detected based on customer settings (only Advanced version)
 - Empty pipe – no water in the pipe / sensor
 - Low impedance - measured electrode impedance below customer low impedance level
 - Flow limit – actual flow exceeds selected high flow limited

Meter status (tamper monitoring of revenue data)

Monitoring of important revenue parameters and data

- Changing totalizers 1 and 2
- Changing Tariff totalizer
- Changing Tariff settings
- Changing date and time
- Alarm has been active (see alarm log for details)
- Fault log has been reset
- Hardware parameter protection has been broken
- Meter has been repowered

Data protection

- All data stored in an EEPROM. Totalizers 1 and 2 are backed up every 10 min, statistic every hour and power consumption and temperature measurement every 4 hour.
- Password protection of all parameters and hardware protection of calibration and revenue parameters.

Battery power management

- Optimal battery information on remaining capacity.
- Calculated capacity includes all consuming elements and available battery capacity is adjusted related to change in ambient temperature.
- Numbers of power ups
- Date and time registered for first and last time power alarm.

Battery operated water meter MAG 8000/MAG 8000 CT

Diagnostic

- Continuous self test including
 - Coil current to drive the magnetic field
 - Signal input circuit
 - Data calculation, handling and storing
- Features
 - Alarm statistics and logging for fault analyzing
 - Electrode impedance to check actual media contact
 - Flow simulation to check pulse and communication signal chain for correct scaling
 - Number of sensor measurements (excitations)
 - Transmitter temperature (battery capacity calculation)
 - Low impedance alarm for change in media
 - Flow alarm when defined high flow exceeds
 - Verification mode for fast measure performance check
- Advanced version includes
 - Insulation „Cross-Talk“ test
 - Meter utilization
 - Consumption profile
 - Statistic flow and consumption data

Insulation test (only Advanced version)

Test of signal immunity against disturbance and bad installation. Test interval is selectable and measurement is interrupted during the test period of 4 min.

Leakage detection (only Advanced version)

Monitoring the lowest flow or volume during selected time window within 24 hours. Leakage is detected over a selectable period where monitored value exceed the possible leakage level. Min and max values are stored with date registration. Last store value visible on the display.

Meter Utilization (only Advanced version)

6 registers for monitoring total time the meter has operated in different flow intervals. Registered intervals are free selectable as % of Qn (Q3)

Tariff (only Advanced version)

6 tariff registers count the volume delivered within the selected tariff windows, based on time of day or flow rates or a combination.

Tariff can also be used for consumption profile where consumption is related to different time intervals or flow rates.

Tariff values visible on the display.

Settling date (only Advanced version)

On a predefined date the totalizer 1 index value is stored. Old values are stored to show the latest two totalized 1 index values.

Settling values visible on the display.

Statistic (only Advanced version)

- Min. flow rate with time and date registration
- Max. flow rate with time and date registration
- Min. daily consumption with date registration
- Max. daily consumption with date registration
- Latest 7 days total and daily consumption
- Actual month consumption
- Latest month consumption

PC Configuration Software

- Flow Tool for parameter configuration and data collection via IrDA interface (free download from internet).
 - Meter configuration – online and offline mode
 - Own parameter settings
 - Parameter documentation
 - Print and export of data and parameters
- Flow Tool meter device drivers version 1.0
 - Versions 1.0, 2.0 and 3.0
 - Latest version downloadable from the Internet
- PDM 6.0 Service Pack 2 – Basic and Online version

Battery operated water meter MAG 8000/MAG 8000 CT

MAG 8000 water meter uncertainty

To ensure continuous accurate measurement, water meters must be calibrated. Calibration is conducted at SIEMENS flow facilities accredited according to ISO/IEC 17025 by DANAK and UKAS.

The accreditation bodies DANAK and UKAS have signed the ILAC MRA agreement (International Laboratory Accreditation Cooperation - Mutual Recognition Arrangement). Therefore the accreditation ensures international traceability and recognition of the test results in 39 countries world wide, including US (NIST traceability).

The selected calibration determines the accuracy of the meter. A standard calibration results in max $\pm 0.4\%$ uncertainty and an extended calibration $\pm 0.2\%$. A calibration certificate follows every sensor and calibration data are stored in the meter unit.

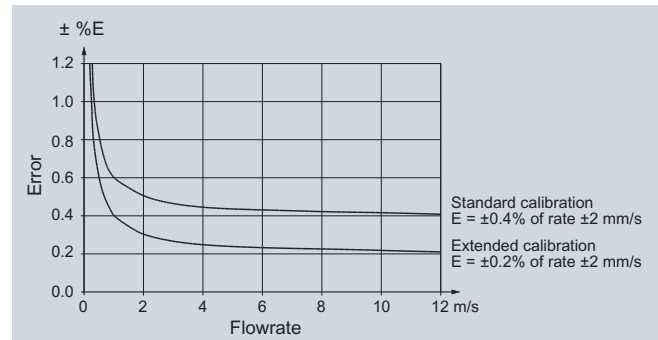

MAG 8000 CT (Revenue program) water meter type approval

MAG 8000 CT program is type approved and verified according to international water meter standard OIML R49. The Custody Transfer program is approved as Class I and Class II, for the sensor program from DN 50 to DN 300, at different Q3 and Q3/Q1. Q2/Q1 = 1.6 and follows standard OIML R49 specification.

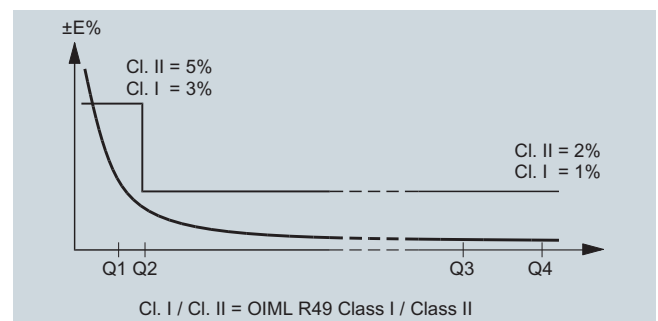

OIML R49 Pattern approval specification for Class I (1%)

Size	50 (2")	65 (2½")	80 (3")	100 (4")	125 (5")	150 (6")	200 (8")	250 (10")	300 (12")
„R“ Q3/Q1	250	250	250	250	250	250	250	250	160
Q4 [m³/h]	78.75	125	200	312.5	500	787.5	1250	2000	2000
Q3 [m³/h]	63	100	160	250	400	630	1000	1600	1600
Q2 [m³/h]	0.40	0.64	1.00	1.60	2.50	4.00	6.40	10.0	16.0
Q1 [m³/h]	0.25	0.40	0.63	1.00	1.60	2.50	4.00	6.40	10.0

OIML R49 Pattern approval specification for Class II (2%)

Size	50 (2")	65 (2½")	80 (3")	100 (4")	125 (5")	150 (6")	200 (8")	250 (10")	300 (12")
„R“ Q3/Q1	400	400	400	400	400	400	400	400	250
Q4 [m³/h]	78.75	125	200	312.5	500	787.5	1250	2000	2000
Q3 [m³/h]	63	100	160	250	400	630	1000	1600	1600
Q2 [m³/h]	0.25	0.40	0.63	1.00	1.60	2.50	4.00	6.40	10.0
Q1 [m³/h]	0.16	0.25	0.40	0.63	1.00	1.60	2.5	4.0	6.4

MAG 8000 CT (Revenue program) MI-001

MAG 8000 CT program is type approved according to international water meter standard OIML R49. Since the first November 2006 the MI-001 water meter directive is in force, which means that all water meters can be sold across the EU borders if the water meters contain a MI-001 label.

The MAG 8000 CT MI-001 verified and labeled products are a Class II approval according to Directive 2004/22/EC of the European Parliament and Council of March 31, 2004 on measuring instruments (MID), Annex MI-001 in the sizes from DN 50 to DN 300.

The MID certification is obtained as a modul B + D module approval according to the above mentioned directive.

Module B : Type approval according to OIML R49

Module D : Quality insurance approval of production

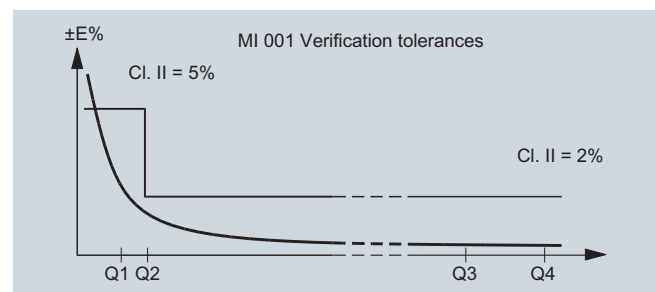

Battery operated water meter MAG 8000/MAG 8000 CT

MAG 8000 CT MI-001 verified and labeled products at a given Q3 and Q3/Q4 = 1,25 and Q2/Q1 = 6,3 measuring ranges see below table:

DN	50 (2")	65 (2½")	80 (3")	100 (4")	125 (5")	150 (6")	200 (8")	250 (10")	300 (12")
„R“ Q3/Q1	25	25	25	25	25	25	25	25	25
Q4 [m³/h]	19	31	50	75	125	188	313	500	750
Q3 [m³/h]	15	25	40	60	100	150	250	400	600
Q2 [m³/h]	3.78	6.30	10.1	15.1	25.2	37.8	63.0	100.8	151.2
Q1 [m³/h]	0.60	1.00	1.60	2.40	4.0	6.0	10.0	16.0	24.0

DN	50 (2")	65 (2½")	80 (3")	100 (4")	125 (5")	150 (6")	200 (8")	250 (10")	300 (12")
„R“ Q3/Q1	63	63	63	63	63	63	63	63	63
Q4 [m³/h]	19	31	50	75	125	188	313	500	750
Q3 [m³/h]	15	25	40	60	100	150	250	400	600
Q2 [m³/h]	1.50	2.50	4.0	6.0	10.0	15.0	25.0	40.0	60.0
Q1 [m³/h]	0.24	0.40	0.63	0.95	1.59	2.38	3.97	6.35	9.52

DN	50 (2")	65 (2½")	80 (3")	100 (4")	125 (5")	150 (6")	200 (8")	250 (10")	300 (12")
„R“ Q3/Q1	80	80	80	80	80	80	80	80	80
Q4 [m³/h]	19	31	50	75	125	188	313	500	750
Q3 [m³/h]	15	25	40	60	100	150	250	400	600
Q2 [m³/h]	1.18	1.97	3.15	4.73	7.88	11.81	19.69	31.50	47.25
Q1 [m³/h]	0.19	0.31	0.50	0.75	1.25	1.88	3.13	5.00	7.50

The Label is placed on the side of the encapsulation. An example of the product label is shown below:



Installation conditions

Please refer to "System information SITRANS F M electromagnetic flowmeters".
MAG 8000 CT has to be mounted in Integral (compact) and horizontal position only, to obtain the MI-001 certification.
Battery packs must be installed with the top part in upwards direction to reach maximum capacity.

Bonding and grounding

The sensor body must be grounded using grounding/bonding straps and/or grounding rings to protect the flow signal against stray electrical noise and/or lightning. This ensures that the noise is carried through the sensor body and a noise-free measuring area within the sensor body.

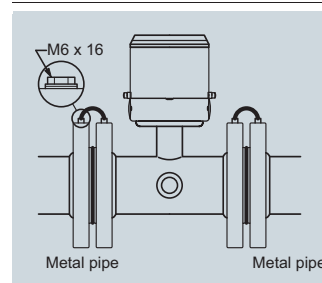

Metal pipelines

On metal pipelines, connect the straps to both flanges.

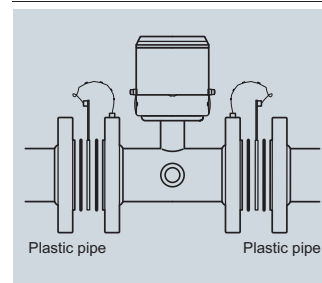

Plastic pipelines

On plastic pipelines and lined metal pipes, optional grounding rings must be used at both ends.
Grounding rings has to be ordered separately see „grounding ring KIT“

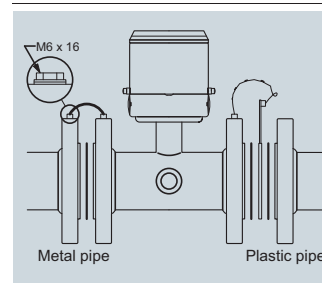

Combination of metal and plastic pipelines

A combination of metal and plastic requires straps for metal pipeline and grounding rings for plastic pipeline.



Battery operated water meter MAG 8000/MAG 8000 CT

Output configuration MAG 8000

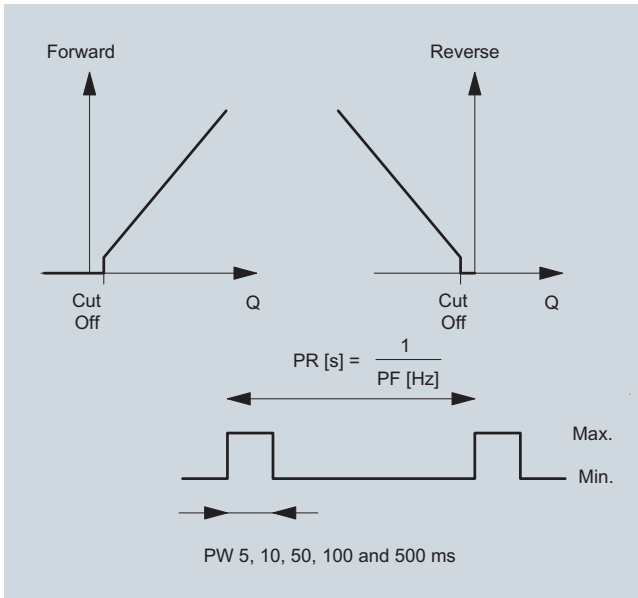

Pulse volume: Output A/B configured as volume per pulse, the output delivers a pulse when the preset volume has passed the selected direction, calculated on forward/reverse or Net forward/reverse flow. The volume per pulse is freely scalable, from 0.0001 to 10000 meter-unit per pulse. PR = pulse rate and PF = pulse frequency.

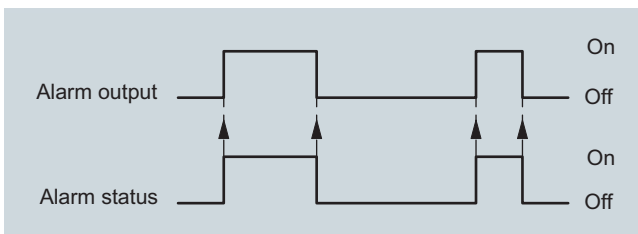

Alarm: The alarm will follow the internal alarm status.

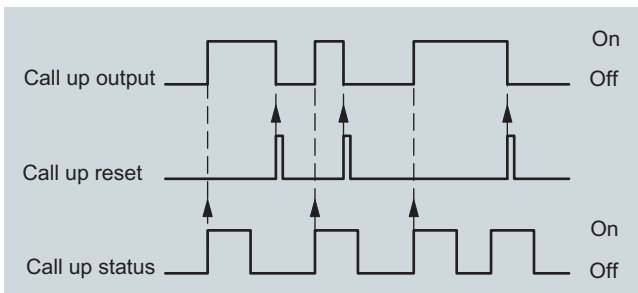

Call up: The "call-up" output is active until manually reset via key on display or via communication. The call-up function is activated when an alarm is activated.

MAG 8000 has a special net pulse output that includes bidirectional flow calculations. This is special for installations where the meter is connected to a system with only one input. The example shows that over time, the net pulse output indicates the bidirectional totalized meter calculations. Same principle for forward and reverse flow calculations.

Flow	Net totalizer in meter display (Bi-directional)	Pulse output forward Uni-directional mode		Pulse output net forward Bi-directional mode	
	Volume [m ³]	Internal calculation	Delivered volume	Internal calculation	Delivered volume
	0	-	0	0	0
	10	-	10	0	10
	-2	-	0	-12	0
	18	-	20	-12+20=	8
Total accounted volume [m ³] Forward/reverse	18F	-	30F		18F

Output configuration MAG 8000 CT

MAG 8000 CT has same output functionality as MAG 8000, due to MI-001 is only forward flow (output A predefined) and output B as Alarm output available).

Battery operation time and calculation

The battery operation time depends on the connected battery pack as well as the operation condition of the meter. A program is available to calculate your expected operation time.

MAG 8000 calculates the remaining capacity every 4 hours and included all consuming elements. Calculation compensates for temperature influence on battery capacity (drawing).

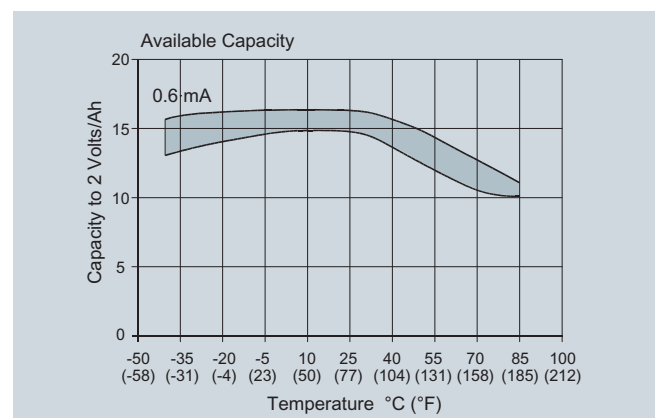

Battery operated water meter MAG 8000/MAG 8000 CT

The effect from other temperatures can be seen from the figure. A variation in temperature from 15 °C to 55 °C (59 to 131 °F) reduces the capacity by 17% in the table from 15 Ah to 12.5 Ah.

At typical revenue scenario of expected battery operation time can be seen in the table. For other scenario use the battery operation calculation program (Download from the Internet).

The measurement is only completed if the system has no active fatal faults or the empty pipe is active. Maximum battery specification is 10 years operation.

Scenario - Revenue application

Output A	Pulse rate max. 10 Hz
Output B	Alarm or call-up
Meter dialog	1 hour per month
Add-com	None
Temperature profile	<ul style="list-style-type: none"> • 5% at 0 °C (32 °F) • 80% at 15 °C (59 °F) • 15% at 50 °C (122 °F)

Excitation frequency (24 h operation)		1/30 Hz	1/15 Hz	3.125 Hz	6.25 Hz
One D-Cell battery 16.5 Ah Internal mains backup for 10 years operation	DN 25 ... 200 (1" ... 8")	1½ year	1 year	20 days	10 days
	DN 250 ... 600 (10" ... 24")	1 year	8 months	10 days	NA
Two D-Cell battery 33 Ah Internal battery pack	DN 25 ... 200 (1" ... 8")	8 year	6 year	4 months	2 months
	DN 250 ... 600 (10" ... 24")	6 year	4 year	2 months	NA
Four D-Cell battery 66 Ah External battery pack	DN 25 ... 200 (1" ... 8")	10 year	10 year	8 months	4 months
	DN 250 ... 600 (10" ... 24")	10 year	8 year	4 months	NA

External battery pack can be used as battery backup for mains power supply.

Serial RS 232/RS 485 add-on communication modules are designed for mains powered systems as the battery operation time will be reduced. At 1 hour communication per month (all meter data collected 2 times per day) and the module is connected, the operation time is reduced to:

- RS 232 at low excitation frequency to 10% and at high excitation frequency to 80% of calculated operation time
- RS 485 at low excitation frequency to 50% and at high excitation frequency to 90% of calculated operation time



**Battery operated water meter
MAG 8000/MAG 8000 CT**

Selection and Ordering data	Order No.
SITRANS F M	
MAG 8000 water meter	7 ME 6 8 1 0 -
Diameter	
DN 25 (1")	2 D
DN 40 (1½")	2 R
DN 50 (2")	2 Y
DN 65 (2½")	3 F
DN 80 (3")	3 M
DN 100 (4")	3 T
DN 125 (5")	4 B
DN 150 (6")	4 H
DN 200 (8")	4 P
DN 250 (10")	4 V
DN 300 (12")	5 D
DN 350 (14")	5 K
DN 400 (16")	5 R
DN 450 (18")	5 Y
DN 500 (20")	6 F
DN 600 (24")	6 P
DN 700 (28") ⁴⁾	6 Y
DN 750 (30") ⁴⁾	7 D
DN 800 (32") ⁴⁾	7 H
DN 900 (36") ⁴⁾	7 M
DN 1000 (40") ⁴⁾	7 R
DN 1050 (42") ⁴⁾	7 T
DN 1100 (44") ⁴⁾	7 V
DN 1200 (48") ⁴⁾	8 B
Flange norm and pressure rating	
<u>EN 1092-1</u>	
PN 10 (DN 200 ... 1200 (8" ... 48"))	B
PN 16 (DN 50 ... 1200 (2" ... 48"))	C
PN 40 (DN 25 ... 40 (1" ... 1½"))	F
<u>ANSI B16.5</u>	
Class 150	J
<u>AS4087</u>	
PN 16	N
Sensor version	
EPDM liner and Hastelloy electrodes	3
Calibration	
Standard ± 0.4% of rate ± 2 mm/s	1
Extended ± 0.2% of rate ± 2 mm/s DN 50 ... 300 (2" ... 12")	2
Region version¹⁾	
Europe (m ³ , m ³ /h, 50 Hz)	1
USA (Gallon, GPM, 60 Hz)	2
Australia (ML, l/h, 50 Hz)	3
Transmitter type and installation	
Basic version integral on sensor	A
Basic version remote, 5 m (16.4 ft) mounted cable on sensor with IP68/NEMA 6P plugs	B
Do - 10 m (32.8 ft)	C
Do - 20 m (65.6 ft)	D
Do - 30 m (98.4 ft)	E
Advanced version integral on sensor	K
Advanced version remote, 5 m mounted cable on sensor with IP68/NEMA 6P plugs	L
Do - 10 m (32.8 ft)	M
Do - 20 m (65.6 ft)	N
Do - 30 m (98.4 ft)	P

Selection and Ordering data	Order No.
SITRANS F M	
MAG 8000 water meter	7 ME 6 8 1 0 -
Communication interface	
No additional "add-on" communication module installed	A
Serial RS 485 with MODBUS RTU (Terminated as end device)	B
Serial RS 232 with MODBUS RTU	C
Power supply²⁾	
Internal battery (no battery included)	0
Internal battery pack installed ³⁾	1
External battery with 1.5 m (4.9 ft) power cable with IP68/NEMA 6P plugs, no battery included	2
12/24 V AC/DC power supply with battery backup and 3 m (9.8 ft) power cable for external connection. (Battery not included)	3
115/230 V AC power supply with battery backup and 3 m (9.8 ft) power cable for external connection. (Battery not included)	4
Additional information	
1) Integral (compact) transmitter is mandatory for MI-001 certified products	
2) MI-001 certified products only battery driven	
3) Lithium batteries are subject to special transportation regulations according to United Nations "Regulation of Dangerous Goods, UN 3090 and UN 3091". Special transport documentation is required to observe these regulations. This may influence both transport time and costs.	
4) The Diameter DN 700 (28") to DN 1200 (48") is only available as <u>remote transmitter type installation</u> .	
Selection and Ordering data	Order code
Additional information	
Please add "-Z" to Order No. and specify Order code(s) and plain text.	
Flow unit	
l/s	L00
MGD	L01
CFS	L02
l/min	L03
m ³ /min	L04
GPM	L05
CFM	L06
l/h	L07
m ³ /h	L08
GPH	L09
CFH	L10
GPS	L11
MI/d	L12
m ³ /d	L13
GPD	L14
Totalizer	
Volume calculation (default totalizer 1= forward and totalizer 2 = reverse)	
Totalizer 1 = RV, reverse flow	L20
Totalizer 1 = NET, net flow	L22
Totalizer 2 = FW, forward flow	L30
Totalizer 2 = NET, net flow	L31

Battery operated water meter MAG 8000/MAG 8000 CT

Selection and Ordering data	Order code
Additional information	
Please add “-Z” to Order No. and specify Order code(s) and plain text.	
<u>Volume unit</u>	
m ³	L40
MI	L41
G	L42
AF	L43
l x 100	L44
m ³ x 100	L45
G x 100	L46
CF x 100	L47
MG	L48
G x 1000	L49
CF x 1000	L50
AI	L51
kl	L52
<u>Pulse set up</u> (default pulse A= forward and pulse B = Alarm)	
A function = RV, reverse flow	L62
A function = FWnet, forward net flow	L63
A function = RVnet, reverse net flow	L64
A function = Off	L65
Volume per pulse A = x 0.0001	L70
Volume per pulse A = x 0.001	L71
Volume per pulse A = x 0.01	L72
Volume per pulse A = x 0.1	L73
Volume per pulse A = x 1	L74
B function = FW, forward flow	L80
B function = RV, forward flow	L81
B function = FWnet, forward net flow	L82
B function = RVnet, reverse net flow	L83
B function = Alarm	L84
B function = Call up	L85
Volume per pulse B = x 0.0001	L90
Volume per pulse B = x 0.001	L91
Volume per pulse B = x 0.01	L92
Volume per pulse B = x 0.1	L93
Volume per pulse B = x 1	L94
<u>Various</u>	
Protection of CT parameters	M02
<u>Data logger set up</u> (default month logging)	
DataloggerInterval = Daily	M31
DataloggerInterval = Weekly	M32
<u>Factory mounted cables</u>	
5 m (16.4 ft) pulse cable A+B	M81
5 m (16.4 ft) communication cable RS 232/RS 485 terminated as end device	M82
2 x 5 m (16.4 ft) pulse A+B and communication cable	M83
20 m (65.6 ft) pulse cable A+B	M84
20 m (65.6 ft) communication cable RS 232/RS 485 terminated as end device	M85
2 x 20 m (65.6 ft) pulse A+B and communication cable	M86
Cello 2 channel, input cable 3 m (9.84 ft) with Brad Harrison micro-change 3 way connector	M87
Cello 2 channel, input cable 5 m (16.4 ft) with MIL-C-26482 spec. connectors	M89



**Battery operated water meter
MAG 8000/MAG 8000 CT**

Selection and Ordering data	Order No.
SITRANS F M	
MAG 8000 CT water meter with EPDM liner and Hastelloy electrodes	7 ME 6 8 2 0 -
	■ ■ ■ ■ 0 ■ - ■ ■ ■ ■
Diameter	
DN 50 (2")/Q3 63 m ³ /h (m ³) without verification or DN 50 (2")/Q3 15 m ³ /h (m ³) with MI-001 verification	2 Y
DN 65 (2½")/Q3 100 m ³ /h (m ³) without verification or DN 65 (2½")/Q3 25 m ³ /h (m ³) with MI-001 verification	3 F
DN 80 (3")/Q3 150 m ³ /h (m ³) without verification or DN 80 (3")/Q3 40 m ³ /h (m ³) with MI-001 verification	3 M
DN 100 (4")/Q3 250 m ³ /h (m ³) without verification or DN 100 (4")/Q3 60 m ³ /h (m ³) with MI-001 verification	3 T
DN 125 (5")/Q3 400 m ³ /h (m ³) without verification or DN 125 (5")/Q3 100 m ³ /h (m ³) with MI-001 verification	4 B
DN 150 (6")/Q3 629 m ³ /h (m ³) without verification or DN 150 (6")/Q3 150 m ³ /h (m ³) with MI-001 verification	4 H
DN 200 (8")/Q3 997 m ³ /h (m ³) without verification or DN 200 (8")/Q3 250 m ³ /h (m ³) with MI-001 verification	4 P
DN 250 (10")/Q3 1600 m ³ /h (m ³) without verification or DN 250 (10")/Q3 400 m ³ /h (m ³) with MI-001 verification	4 V
DN 300 (12")/Q3 2500 m ³ /h (m ³) without verification or DN 300 (12")/Q3 600 m ³ /h (m ³) with MI-001 verification	5 D
Flange norm and pressure rating	
<u>EN 1092-1</u>	
PN 16	C
<u>ANSI B16.5</u>	
Class 150	J
<u>AS4087</u>	
PN 16	N
Approval/Verification	
Without verification according to OIML R49	0
MI-001 Q3/Q1 = 25	1
MI-001 Q3/Q1 = 63	2
MI-001 Q3/Q1 = 80	3
Region version	
Europe (m ³ , m ³ /h, 50 Hz) ¹⁾	1
USA (m ³ , m ³ /h, 60 Hz)	2
Transmitter type and installation	
Basic version integral on sensor ¹⁾	A
Basic version remote, 5 m (16.4 ft) mounted cable on sensor with IP68/NEMA 6P plugs	B
Do - 10 m (32.8 ft)	C
Advanced version integral on sensor ¹⁾	K
Advanced version remote, 5 m mounted cable on sensor with IP68/NEMA 6P plugs	L
Do - 10 m (32.8 ft)	M
Communication interface	
No additional "add-on" communication module installed	A
Serial RS 485 with MODBUS RTU (Terminated as end device)	B
Serial RS 232 with MODBUS RTU	C

Selection and Ordering data	Order No.
SITRANS F M	
MAG 8000 CT water meter with EPDM liner and Hastelloy electrodes	7 ME 6 8 2 0 -
	■ ■ ■ ■ 0 ■ - ■ ■ ■ ■
Power supply³⁾	
Internal battery (no battery included)	0
Internal battery pack installed ²⁾	1
External battery with 1.5 m (4.9 ft) power cable with IP68/NEMA 6P plugs, no battery included	2
12/24 V AC/DC power supply with battery backup and 3 m (9.8 ft) power cable for external connection. (Battery not included)	3
115/230 V AC power supply with battery backup and 3 m (9.8 ft) power cable for external connection. (Battery not included)	4













- ¹⁾ Integral (compact) transmitter is mandatory for MI-001 certified products
- ²⁾ Lithium batteries are subject to special transportation regulations according to United Nations "Regulation of Dangerous Goods, UN 3090 and UN 3091". Special transport documentation is required to observe these regulations. This may influence both transport time and costs.
- ³⁾ MI-001 certified products only battery driven.

Selection and Ordering data	Order code
Additional information	
Please add "-Z" to Order No. and specify Order code(s) and plain text.	
<u>Pulse set up</u> (default pulse A= forward and pulse B = Alarm)	
Volume per pulse A = x 0.001 m ³	L71
Volume per pulse A = x 0.01 m ³	L72
Volume per pulse A = x 0.1 m ³	L73
Volume per pulse A = x 1 m ³	L74
<u>Data logger set up</u> (default month logging)	
DataloggerInterval = Daily	M31
DataloggerInterval = Weekly	M32
<u>Factory mounted cables</u>	
5 m (16.4 ft) pulse cable A+B	M81
5 m (16.4 ft) communication cable RS 232/RS 485 terminated as end device	M82
2 x 5 m (16.4 ft) pulse A+B and communication cable	M83
20 m (65.6 ft) pulse cable A+B	M84
20 m (65.6 ft) communication cable RS 232/RS 485 terminated as end device	M85
Cello 2 channel, input cable 3 m (9.84 ft) with Brad Harrison micro-change 3 way connector	M87
Cello 2 channel, input cable 5 m (16.4 ft) with MIL-C-26482 spec. connectors	M89

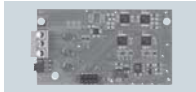

Battery operated water meter MAG 8000/MAG 8000 CT

Accessories

Description	Order No.		Description	Order No.	
PC Flow Tool on CD (Download for free from www.siemens.com/flow)	FDK-087L6001		One cable entry 6 ... 8 mm (0.02 ... 0.026 ft) M20 brass glands package (10 pcs)	FDK-087L4155	
IrDA infrared interface adapter with USB for data acquisition with 1.2 m (3.9 ft) cable	FDK-087L4163		One cable entry 8 ... 11 mm (0.026 ... 0.036 ft) M20 brass glands package (10 pcs)	FDK-087L4156	
Battery backup for mains power supply, one pc. D-cell (3.6 V, 16.5 Ah) Attention on note ¹⁾	FDK-087L4201		One cable entry 11 ... 15 mm (0.036 ... 0.049 ft) M20 brass glands package (10 pcs)	FDK-087L4157	
Internal battery pack, one set D-cell (3.6 V 33 Ah) and accessories for replacement Attention on note ¹⁾	FDK-087L4150		Two cable entries 3.5 ... 5 mm (0.011 ... 0.016 ft) M20 brass glands package (10 pcs)	FDK-087L4158	
External battery pack IP68/NEMA 6P with connec- tor, four D-cell (3.6 V 66 Ah) Attention on note ¹⁾	FDK-087L4151		Two cable entries 5.5 ... 7.5 mm (0.018 ... 0.024 ft) M20 brass glands package (10 pcs)	FDK-087L4159	
Mains power supply 12 ... 24 V AC/DC with bat- tery backup and 3 m (9.8 ft) power cable for external connection (no battery included)	FDK-087L4210		IP68/NEMA 6P potting kit	FDK-085U0220	
Mains power supply 115 ... 230 V AC with battery backup up and 3 m (9.8 ft) power cable for external connection (no battery included)	FDK-087L4211		MAG 8000 Hardware key to access protected param- eters	FDK-087L4165	
RS 232 add-on module, point to point communi- cation interface with MODBUS RTU protocol	FDK-087L4212		MAG 8000 demo - training unit pack operating on Alka- line batteries. Transmitter with Flow tool CD, IrDA inter- face adapter and hardware key (No dangerous goods limitations)	FDK-087L4080	
RS485 add-on module, mul- tidrop communication inter- face with MODBUS RTU protocol	FDK-087L4213		Alkaline battery for MAG 8000 demo transmit- ter (3 V 13 Ah) (No dangerous goods limita- tions)	FDK-087L4142	
One cable entry 6 ... 8 mm (0.02 ... 0.026 ft) M20 brass glands package (1 pc)	FDK-087L4196				
One cable entry 3.5 ... 5 mm (0.011 ... 0.016 ft) M12 brass glands with M20 reduction. Package of 10 pcs	FDK-087L4154				

¹⁾ Lithium batteries are subject to special transportation regulations according to United Nations "Regulation of Dangerous Goods, UN 3090 and UN 3091". Special transport documentation is required to observe these regulations. This may influence both transport time and costs.



Battery operated water meter MAG 8000/MAG 8000 CT

MAG 8000 has built in Hastelloy grounding electrodes, when installed in PVC or coated pipelines, grounding rings must be installed additionally.

Grounding rings, type C must be used for sizes > DN 300. Grounding rings DN 25 to DN 300 in stainless steel are packed in pairs and sold as a "grounding ring kit". The corresponding order number for each of the dimensions are described in the below table.

Dimension	Order No.
DN 25	A5E01002946 ^{F)}
DN 40	A5E01002947 ^{F)}
DN 50	A5E01002948 ^{F)}
DN 65	A5E01002950 ^{F)}
DN 80	A5E01002952 ^{F)}
DN 100	A5E01002953 ^{F)}
DN 125	A5E01002954 ^{F)}
DN 150	A5E01002955
DN 200	A5E01002957 ^{F)}
DN 250	A5E01002958 ^{F)}
DN 300	A5E01002962 ^{F)}



Spare parts

Description	Order No.
MAG 8000 (Basic version) transmitter compact replacement kit. System number specified by ordering. No battery included	FDK-087L4166
MAG 8000 (Basic version) transmitter remote replacement kit. System number specified by ordering. No battery included	FDK-087L4202
MAG 8000 (Advanced version) transmitter compact replacement kit. No battery included	FDK-087L4203
MAG 8000 (Advanced version) transmitter remote replacement kit. No battery included.	FDK-087L4204
MAG 8000 (Basic version) transmitter PCB replacement kit	A5E01171569
MAG 8000 (Advanced version) transmitter PCB replacement kit	FDK-087L4168



Description	Order No.
Enclosure top including plastic lid, screws and blank product label	FDK-087L4167
Cable for external battery pack, 1.5 m (4.92 ft) with IP68/NEMA 6P connector	FDK-087L4152
Service tool kit package with various component for service and replacement.	FDK-087L4162
Remote cable set 5 m (16.4 ft) with IP68/NEMA 6P plugs - PG 13.5	FDK-087L4108
Remote cable set 5 m (16.4 ft) with IP68/NEMA 6P plugs - M20	On request
Remote cable set 10 m (32.8 ft) with IP68/NEMA 6P plugs - PG 13.5	FDK-087L4109
Remote cable set 10 m (32.8 ft) with IP68/NEMA 6P plugs - M20	On request
Remote cable set 20 m (65.6 ft) with IP68/NEMA 6P plugs - PG 13.5	FDK-087L4110
Remote cable set 20 m (65.6 ft) with IP68/NEMA 6P plugs - M20	On request
Remote cable set 30 m (98.4 ft) with IP68/NEMA 6P plugs - PG 13.5	FDK-087L4111
Remote cable set 30 m (98.4 ft) with IP68/NEMA 6P plugs - M20	On request



F) Subject to export regulations AL: 91999, ECCN: N.

**Battery operated water meter
MAG 8000/MAG 8000 CT**

Dimensional drawings

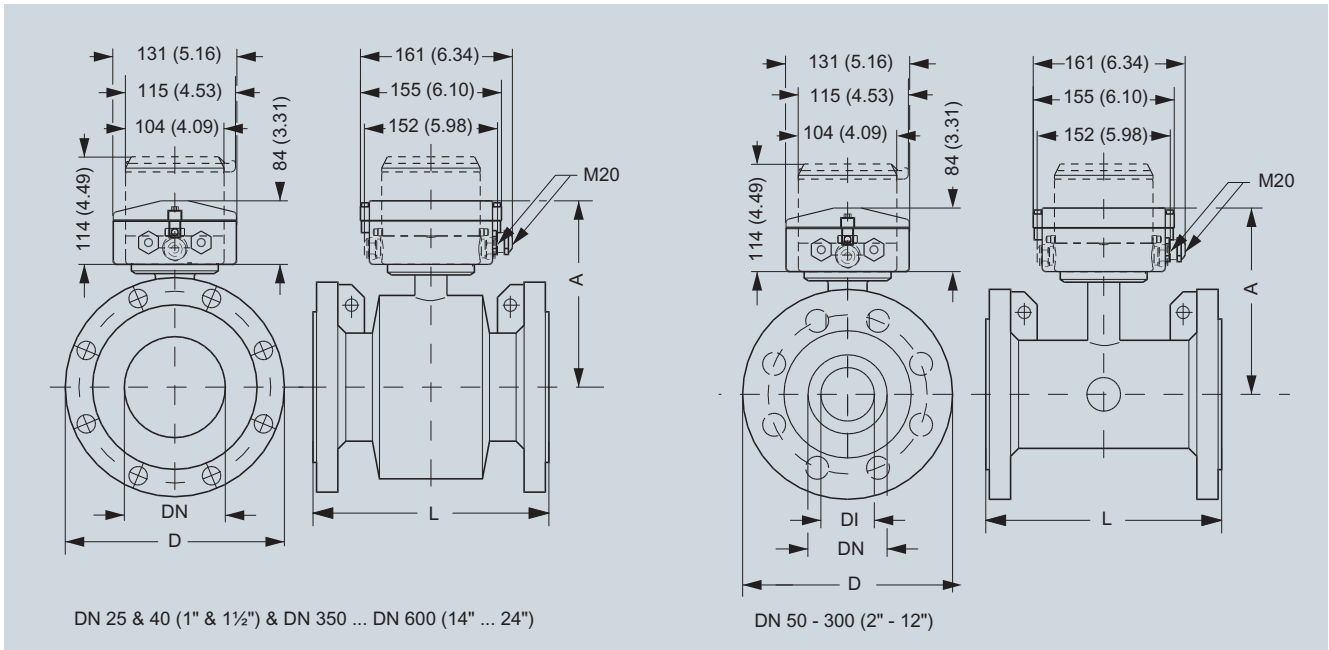

Nominal DN size	A	L, lengths					D, diameter		Weight ¹⁾	
		EN 1092-1 PN 10	EN 1092-1 PN 16	EN 1092-1 PN 40	ANSI 16.5 Class 150	AS 4087 PN 16	DI	D	kg	lbs
25 (1)	194 (7.7)	-	-	200	7.9	200	25 (0.98)	See flange table	6	13
40 (1½)	204 (8.1)	-	-	200	7.9	200	40 (1.57)	See flange table	9	20
50 (2)	195 (7.7)	-	200	-	7.9	200	42 (1.65)	See flange table	11	25
65 (2½)	201 (8)	-	200	-	7.9	200	55 (2.17)	See flange table	13	29
80 (3)	207 (8.2)	-	200	-	7.9	200	67 (2.64)	See flange table	15	34
100 (4)	214 (8.5)	-	250	-	9.8	250	81 (3.19)	See flange table	17	38
125 (5)	224 (8.9)	-	250	-	9.8	250	101 (3.98)	See flange table	22	50
150 (6)	239 (9.5)	-	300	-	11.8	300	131 (5.16)	See flange table	28	63
200 (8)	264 (10.5)	350	350	-	13.8	350	169 (6.65)	See flange table	50	113
250 (10)	291 (11.5)	450	450	-	17.7	450	212 (8.35)	See flange table	71	160
300 (12)	317 (12.6)	500	500	-	19.7	500	265 (10.43)	See flange table	88	198
350 (14)	369 (14.6)	550	550	-	21.7	550	350 (13.78)	See flange table	127	279
400 (16)	394 (15.6)	600	600	-	23.6	600	400 (15.75)	See flange table	145	318
450 (18)	425 (16.8)	600	600	-	23.6	600	450 (17.72)	See flange table	175	384
500 (20)	450 (17.8)	600	600	-	26.8	600	500 (19.68)	See flange table	225	494
600 (24)	501 (19.8)	600	600	-	32.3	600	600 (23.62)	See flange table	340	747
700 (28)	544 (21.4)	875	875	-	N/A	N/A	700 (27.55)	See flange table	316	694
750 (30)	571 (22.5)	N/A	N/A	-	N/A	N/A	750 (29.52)	See flange table	N/A	N/A
800 (32)	606 (23.9)	1000	1000	-	N/A	N/A	800 (31.49)	See flange table	398	1045
900 (36)	653 (25.7)	1125	1125	-	N/A	N/A	900 (35.42)	See flange table	476	1045
1000 (40)	704 (27.7)	1250	1250	-	N/A	N/A	1000 (39.36)	See flange table	602	1322
1050 (42)	704 (27.7)	N/A	N/A	-	N/A	N/A	1050 (41.33)	See flange table	N/A	N/A
1100 (44)	755 (29.7)	N/A	N/A	-	N/A	N/A	1100 (43.30)	See flange table	N/A	N/A
1200 (48)	810 (31.9)	1500	1500	-	N/A	N/A	1200 (47.23)	See flange table	887	1996

¹⁾ For remote version the sensor weight is reduced with 2 kg (4.5 lb)

Remote version

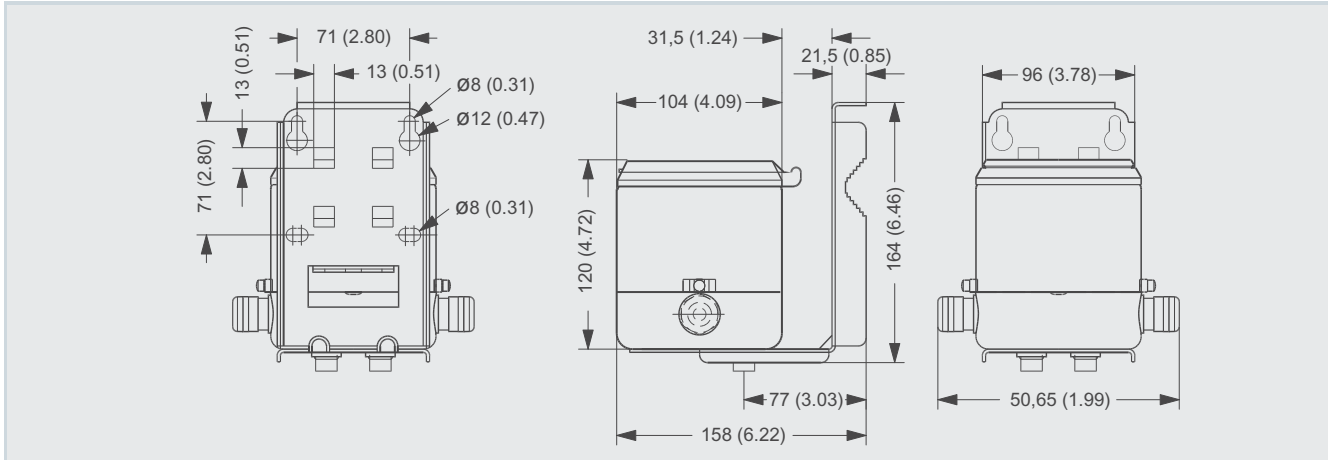

Dimensions in mm (inch), weight 3.5 kg (8 lbs)

External battery pack

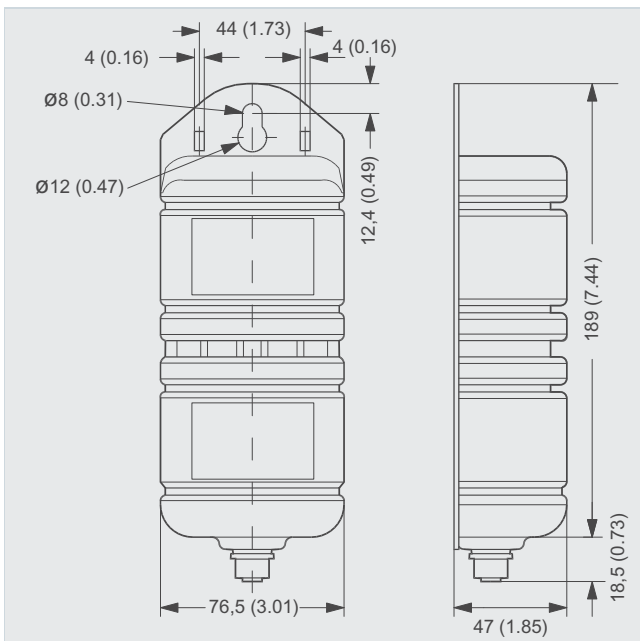

Dimensions in mm (inch), weight 2.0 kg (4.5 lbs)

Battery pack has to be mounted in upwards position to ensure maximum battery capacity.

Grounding rings

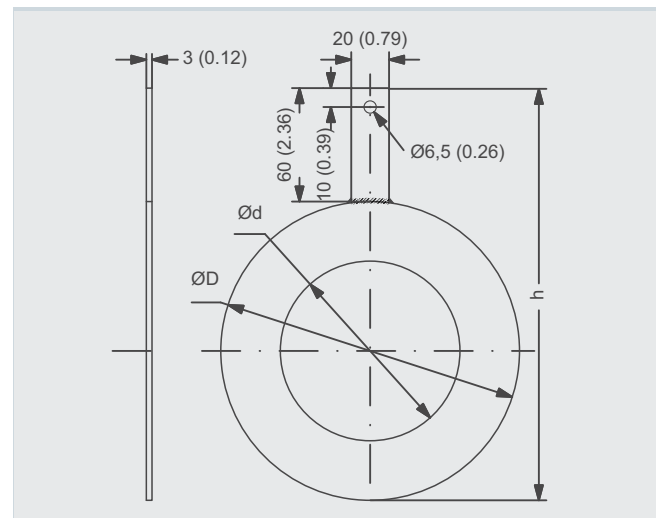

Dimensions in mm for grounding rings MAG 8000 DN 25 to DN 300

Dimension	Internal diameter (d)	Outside diameter (D)	h
DN 25	27	68	88
DN 40	38	88	105
DN 50	52	100	113
DN 65	64	120	123
DN 80	79	133	130
DN 100	95	158	145
DN 125	115	188	155
DN 150	145	216	175
DN 200	193	268	200
DN 250	246	324	230
DN 300	295	374	253



Battery operated water meter MAG 8000/MAG 8000 CT

Schematics

Electrical installation and pulse output – Connection diagram

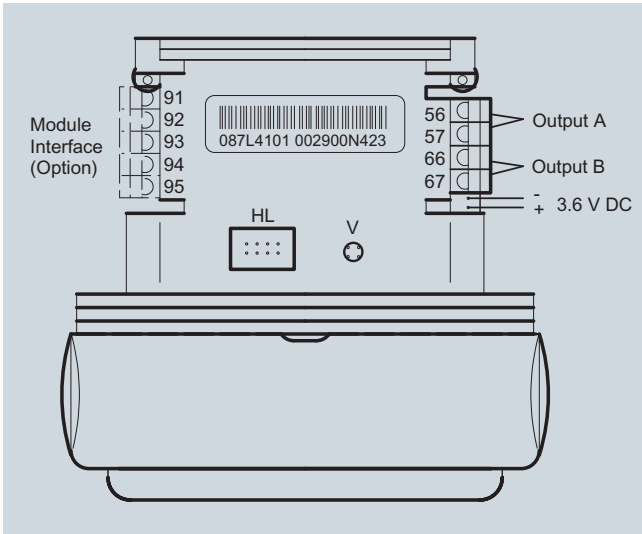

HL = Hardware lock key connection
V = Push button for verification mode

Pulse wire connection

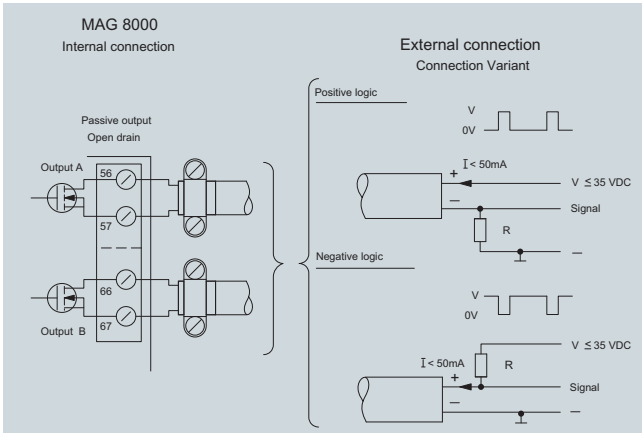

The pulse output can be configured as volume, alarm or call-up. The output can be connected as positive or negative logic. R = pull up/down is selected in relation to the Vx power supply and with a max. current I of 50 mA.

Use shielded cable to avoid EMC problems. Make sure the shield is correct mounted under the cable clamp (no pig tail).

Remote installation

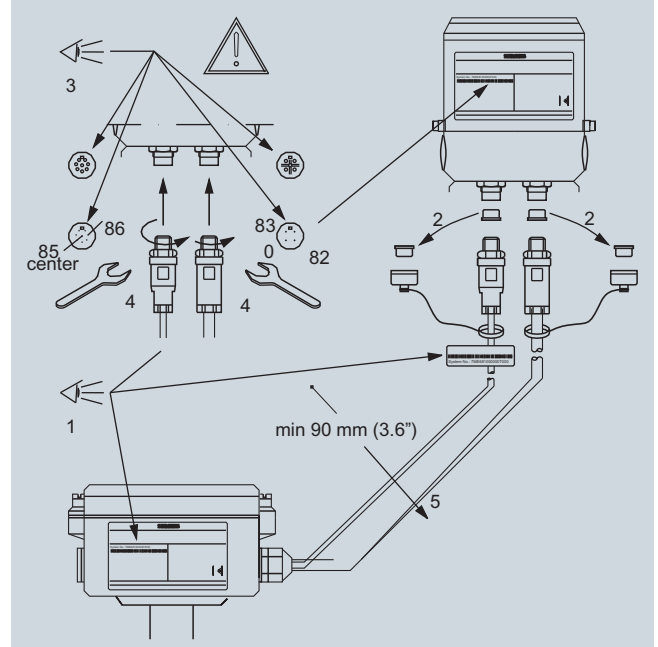

Remote solutions have factory mounted sensor cable with IP68/ NEMA 6P plugs. Sensor cable has meter label (1) with system number to ensure transmitter and sensor are correct matched. The dust cover on the cable end and on the transmitter bottom must be screwed together for future protection (2). The connectors must be clean and duly fastened to secure a good signal detection (3+4).

