

Overview



The SITRANS F M MAG 6000 I/MAG 6000 I Ex transmitter is designed for the demands in the process industry. The robust die cast aluminum housing provides superb protection, even in the most harsh industrial environments. Full input and output functionality is given even in the Ex version.

Benefits

- Full range of Ex-rated flowmeters with intrinsically safe rated input and outputs
- For compact or remote installation
- HART, FOUNDATION Fieldbus H1, DeviceNet, PROFIBUS PA and DP, Modbus RTU/RS 485 add-on communication modules available
- Superior signal resolution for optimum turn down ratio
- Digital signal processing with many possibilities
- Automatic reading of SENSORPROM data for easy commissioning
- User configurable operation menu with password protection
 - 3 lines, 20 characters display in 11 languages
 - Flow rate in various units
 - Totalizer for forward, reverse and net flow as well as much more information available.
- Multiple functional outputs for process control, minimum configuration with analogue, pulse/frequency and relay output (status, flow direction, limits)
- Comprehensive self-diagnostic for error indication and error logging
- Batch control
- MAG 6000 I NAMUR: compliant with NAMUR NE 21, NE 32, NE 43, NE 53 and NE 70

Design

The transmitter is designed for either compact or remote installation in non-hazardous or hazardous areas (compact mounted transmitter to be ordered together with the sensors).

Function

The following functions are available:

- Flow rate
- 2 measuring ranges
- 2 totalizers
- Low flow cut-off
- Flow direction
- Error system
- Operating time
- Uni-/bidirectional flow

- Limit switches and pulse output
- Batch control

The MAG 6000 I/6000 I Ex is a microprocessor-based transmitter with a built-in alphanumeric display in several languages. The transmitters evaluate the signals from the associated electromagnetic sensors and also fulfil the task of a power supply unit which provides the magnet coils with a constant current.

Further information on connection, mode of operation and installation can be found in the data sheets for the sensors.

Displays and keypads

Operation of the transmitter can be carried out using:

- Keypad and display unit
- HART communicator
- PC/laptop and SIMATIC PDM software via HART communication
- PC/laptop and SIMATIC PDM software using PROFIBUS or Modbus communication

Technical specifications

Mode of operation and design

Measuring principle	Electromagnetic with pulsed constant field
Empty pipe	Detection of empty pipe (special cable required in remote mounted installation)
Excitation frequency	Depend on sensor size
Electrode input impedance	$> 1 \times 10^{14} \Omega$
Input	
Digital input	11 ... 30 V DC, $R_i = 4.4 \text{ k}\Omega$
• Activation time	50 ms
• Current	$I_{11 \text{ V DC}} = 2.5 \text{ mA}$, $I_{30 \text{ V DC}} = 7 \text{ mA}$
Output	
Current output	
• Signal range	4 ... 20 mA (active/ passive)
• Load	$< 560 \Omega$
• Time constant	0.1 ... 30 s, adjustable
Digital output	
• Frequency	0 ... 10 kHz, 50 % duty cycle (uni-/bidirectional)
• Time constant	0.1 ... 30 s, adjustable
• Pulse (passive)	3 ... 30 V DC, max 110 mA (30 mA Ex version), $200 \Omega \leq R_i \leq 10 \text{ k}\Omega$ (powered from connected equipment)
• Time constant	0.1 ... 30 s, adjustable
Relay output	
• Time constant	Changeover relay, same as current output
• Load	42 V AC/2 A, 24 V DC/1 A
Low flow cut off	0 ... 9.9 % of maximum flow
Galvanic isolation	All inputs and outputs are galvanic isolated
Max. measuring error	
MAG 6000 I/MAG 6000 I Ex (incl. sensor)	$\pm 0.2 \% \pm 1 \text{ mm/s}$

Flow Measurement

SITRANS F M

Transmitter MAG 6000 I/6000 I Ex

Rated operation conditions	
Ambient temperature	
• Operation	
- MAG 6000 I	-20 ... +60 °C (-4 ... +140 °F)
- MAG 6000 I Ex	-20 ... +60 °C (14 ... 140 °F)
• Storage	-40 ... +70 °C (-40 ... +158 °F)
Mechanical load	18 ... 1000 Hz random in x, y, z, directions for 2 hours according to EN 60068-2-36 Transmitter: 1.14 grms
Degree of protection	IP67/NEMA 4X to IEC 529 and DIN 40050 (1 mH ₂ O 30 min.)
EMC performance	IEC/EN 61326-1 (all environments) IEC/EN 61326-2-5 NAMUR NE 21

Display and keypad	
Totalizer	Two eight-digit counters for forward, net or reverse flow
Display	Background illumination with alphanumeric text, 3 x 20 characters to indicate flow rate, totalized values, settings and faults; Reverse flow indicated by negative sign
Keypad	Capacitive touch keypad with LED light for feedback indication
Time constant	Time constant as current output time constant

Design	
Enclosure material	Die cast aluminum, with corrosion resistant Basic Polyester power coating (min. 60 µm)
• Wall mounting	Wall mounting bracket enclosed for remote version
Dimensions	See dimensional drawings
Weight	See dimensional drawings

Power supply	
	<ul style="list-style-type: none"> Standard transmitter: 18 ... 90 V DC; 115 ... 230 V AC; 50 ... 60 Hz Ex transmitter: 18 ... 30 V DC Ex transmitter: 115 ... 230 V AC; 50 ... 60 Hz Ex transmitter NAMUR: 18 ... 30 V DC; 115 ... 230 V AC; 50 ... 60 Hz
Power consumption	<ul style="list-style-type: none"> 230 V AC: 20 VA 24 V DC: 9.6 W, I_N = 0.4 A, I_{ST} = 1 A (3 ms)

Certificates and approvals	
MAG 6000 I	<ul style="list-style-type: none"> CE C-tick FM Class I, Div 2 FM Class I, Zone 2 CSA Class I, Div 2
MAG 6000 I Ex	<ul style="list-style-type: none"> IEC Ex de [ia] [ib] ia IIC T6 Gb Ex tDa 21 IP67 ATEX II 2(1)(2) GD EEx de [ia] ia [ib] IIC T6 FM Class I, Div 1¹⁾ FM Class I, Zone 1 CSA Class I, Zone 1/21

Cable entries	
MAG 6000 I	Remote installation 2 x M25 (for supply/output) and 2 x M16 (for sensor connection) or 2 x ½" NPT (for supply/output) and 2 x M16 (for sensor connection)
MAG 6000 I Ex ATEX 2G D	2 x M20 (for supply/output) and 2 x M16 (for sensor connection)

Communication	
Standard versions	HART, Modbus RTU/RS 485, FOUNDATION Fieldbus H1, DeviceNet, PROFIBUS PA, PROFIBUS DP add-on modules
Ex versions	HART, PROFIBUS PA,

¹⁾ Applicable for: Compact mounted MAG 6000 I Ex on MAG 3100 (sizes DN 15 ... DN 300 (½" ... 12"))

Selection and Ordering data	Article No.
SITRANS F M Transmitter MAG 6000 I/Ex	7ME6930-
Remote with standard wall mounting bracket, local display, die cast aluminum	2BA-1A
Supply voltage	
Standard transmitter: 18 ... 90 V DC; 115 ... 230 V AC, 50 ... 60 Hz	2
Standard transmitter (NAMUR): 18 ... 30 V DC; 115 ... 230 V AC, 50 ... 60 Hz	3
Ex transmitter: 18 ... 30 V DC	4
Ex transmitter: 115 ... 230 V AC, 50 ... 60 Hz	5
Ex transmitter (NAMUR): 18 ... 30 V DC; 115 ... 230 V AC, 50 ... 60 Hz	6
Ex approval	
Standard sensor: FM Class I, Div 2, CSA Class I, Div 2	0
Ex sensor: Hazardous area (ATEX 2G D; FM Class 1, Zone 1; CSA Class 1, Zone 1)	2
Communication	
None	A
HART	B
PROFIBUS PA Profile 3	F
PROFIBUS DP Profile 3 (not for Ex version)	G
Modbus RTU/RS 485 (not for Ex version)	E
FOUNDATION Fieldbus H1	J
Cable gland entries	
Metric	0
½" NPT	2

• We can offer shorter delivery times for configurations designated with the Quick Ship Symbol •. For details see page 9/5 in the appendix.

Selection and Ordering data	Order code
Further design	
Please add "-Z" to Article No. and specify Order code(s) and plain text.	
Tag name plate, stainless steel fixed with SS wire (add plain text)	Y17
Tag name plate, plastic (self adhesive)	Y18
Other, post-production requirements (add plain text)	Y99

Operating instructions for SITRANS F M MAG 6000 I

Description	Article No.
• English	A5E02083319
• German	A5E02210835
• French	A5E02342413

This device is shipped with a Quick Start guide and a CD containing further SITRANS F literature.

All literature is also available for free at:
<http://www.siemens.com/flowdocumentation>

Flow Measurement

SITRANS F M

Transmitter MAG 6000 I/6000 I Ex

Communication modules for MAG 6000 I (All standard outputs can still be used)

Description	Article No.
HART (only for MAG 6000 I/Ex)	◆ FDK:085U0321
Modbus RTU/RS 485 ¹⁾	◆ FDK:085U0234
PROFIBUS PA Profile 3	◆ FDK:085U0236
PROFIBUS DP Profile 3 ¹⁾	◆ FDK:085U0237
DeviceNet ¹⁾	◆ FDK:085U0229
FOUNDATION Fieldbus H1 ¹⁾	A5E02054250



◆ We can offer shorter delivery times for configurations designated with the Quick Ship Symbol ◆. For details see page 9/5 in the appendix.

¹⁾ Not for Ex versions

Operating instructions for SITRANS F add-on modules

Description	Article No.
HART, English	A5E03089708
PROFIBUS PA/DP	
• English	A5E00726137
• German	A5E01026429
MODBUS	
• English	A5E00753974
• German	A5E03089262
• Spanish	A5E03089278
• French	A5E03089265
FOUNDATION Fieldbus	
• English	A5E02318728
• German	A5E02488856
• Spanish	A5E02512177
• French	A5E02512169
DeviceNet, English	A5E03089720

This device is shipped with a Quick Start guide and a CD containing further SITRANS F literature.

Accessories MAG 6000 I/MAG 6000 I Ex

Description	Article No.
Cable for standard electrode or coil, 3 x 1.5 mm ² /18 gage with shield PVC. Temperature range: -30 ... +70 °C (-22 ... +158 °F)	
• 10 m (33 ft)	◆ FDK:083F0121
• 20 m (65 ft)	◆ FDK:083F0210
• 40 m (130 ft)	◆ FDK:083F0211
• 60 m (200 ft)	◆ FDK:083F0212
• 100 m (330 ft)	FDK:083F0213
• 150 m (500 ft)	FDK:083F3052
• 200 m (650 ft)	FDK:083F3053
• 500 m (1650 ft)	FDK:083F3054
Electrode cable for empty pipe or low conductivity, double shielded, 3 x 0.25 mm ² . Temperature range: -30 ... +70 °C (-22 ... +158 °F)	
• 10 m (33 ft)	◆ FDK:083F3020
• 20 m (65 ft)	◆ FDK:083F3095
• 40 m (130 ft)	FDK:083F3094
• 60 m (200 ft)	FDK:083F3093
• 100 m (330 ft)	FDK:083F3092
• 150 m (500 ft)	FDK:083F3056
• 200 m (650 ft)	FDK:083F3057
• 500 m (1650 ft)	FDK:083F3058



Cable kit with standard coil cable, 3 x 1.5 mm²/18 gage with shield PVC and electrode cable double shielded, 3 x 0.25 mm²

• 5 m (16.5 ft)	◆ A5E02296329
• 10 m (33 ft)	◆ A5E01181647
• 15 m (49 ft)	◆ A5E02296464
• 20 m (65 ft)	◆ A5E01181656
• 25 m (82 ft)	◆ A5E02296490
• 30 m (98 ft)	◆ A5E02296494
• 40 m (130 ft)	◆ A5E01181686
• 50 m (164 ft)	◆ A5E02296498
• 60 m (200 ft)	A5E01181689
• 100 m (330 ft)	A5E01181691
• 150 m (500 ft)	A5E01181699
• 200 m (650 ft)	A5E01181703
• 500 m (1650 ft)	A5E01181705

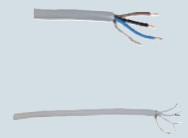

Low noise electrode coax cable for low conductivity and high vibration levels of cables, 3 x 0.13 mm²

• 2 m (6.6 ft)	A5E02272692
• 5 m (16.5 ft)	A5E02272723
• 10 m (33 ft)	A5E02272730



◆ We can offer shorter delivery times for configurations designated with the Quick Ship Symbol ◆. For details see page 9/5 in the appendix.

Spare parts



Description	Article No.
MAG 6000 I Display	FDK:085U3122
Accessory bag including cable gland inserts coil and electrode connectors	FDK:085U3144
Electronics cover with Ex glass plate. Die cast aluminum, with corrosion-resistant Basic Polyester powder coating (min. 60 µm).	7ME5933-0AC01
Cover for connection board incl. gasket (for remote version). Die cast aluminum, with corrosion-resistant Basic Polyester powder coating (min. 60 µm).	7ME5933-0AC02
Cover for mains supply/communication. Die cast aluminum, with corrosion-resistant Basic Polyester powder coating (min. 60 µm).	7ME5933-0AC03



Flow Measurement

SITRANS F M

Transmitter MAG 6000 I/6000 I Ex

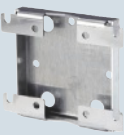
Description	Article No.	
Safety clamp	7ME5933-0AC06	
Standard wall mounting bracket. Steel AISI 316L/EN10088-2-1.4404	7ME5933-0AC04	
Wall-/pipe mounting bracket kit, BI 2,5 DIN59382 X6Cr17	7ME5933-0AC05	

Complete spare part PCB unit

Description	Article No.	
MAG 6000 I PCBA (not for Ex)	FDK:085U3123	
MAG 6000 I std. (NAMUR), 18 ... 30 V DC; 115 ... 230 V AC Spare PCBA unit	A5E31426892	
MAG 6000 I Ex (NAMUR), 18 ... 30 V DC; 115 ... 230 V AC Spare PCBA unit for use with Ex sensors with increased safety e (For Ex sensors: 7ME6110, 7ME6120, 7ME6140, 7ME6310, 7ME6320, 7ME6340) (For 7ME6330 > DN300)	A5E31426877¹⁾	

¹⁾ Ex spare parts may only be exchanged by "Siemens Ex Authorized personnel".

Please use online Product selector to get latest updates.

Product selector link:

www.pia-selector.automation.siemens.com

Dimensional drawings

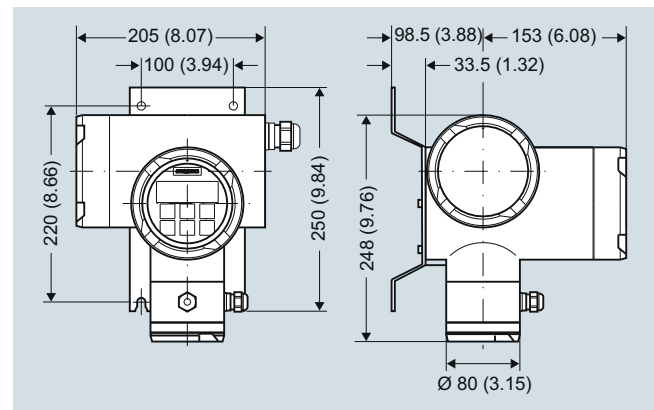

Dimensions in mm (inch), weight: 6 kg (13.5 lb)

Schematics

