

Datasheet N410

User-friendly batch controller

FLUIDWELL
Accurate Liquid Management

Reliable

Count on us.

Batch Controller

with numerical keypad, remote control inputs
and 3 control / alarm / pulse outputs



Advantages

- ✔ Save time and cost with the easy to operate numerical keypad.
- ✔ Your crew is in control with our highly praised “know one, know them all” configuration structure, saving time, cost and aggravation.
- ✔ Key information at a glance as the display simultaneously shows actual value, preset value, batch process indication, relay status and measuring units.
- ✔ Easy installation with the rugged aluminum DIN-size panel mount enclosure.

Features

- ✔ Five control inputs for remote START, HOLD, RESUME, keypad lock and external alarm.
- ✔ 7 large digits for actual value, flow rate, total and 10 smaller digits for preset value, accumulated total and batch count.
- ✔ Selectable on-screen engineering units; volumetric or mass.
- ✔ Power requirements: 24V DC / 110 - 230V AC.
- ✔ Sensor supply: 8.2 / 12 / 24V DC.
- ✔ No-flow monitoring.
- ✔ Automatic overrun correction.
- ✔ Modbus communication option RS232 / RS485.

Outputs

- ✔ Two field replaceable, heavy duty, mechanical relays (make-and-break/ NO-NC), configurable for i.e. batching with one-stage or two-stage control.
- ✔ One transistor output for connection to PLC's or other controlling equipment.

Inputs

- ✔ Ability to process various types of volumetric or mass flowmeter signals: Reed-switch, open collector, NPN, PNP or active 8/12/24V pulse signals.

Applications

- ✔ Accurate batching or filling of liquids where the batch size changes frequently.
- ✔ The N410 offers the perfect solution for batch control applications where a user-friendly instrument is required. Whether you focus on its clear display information, the very easy to operate numerical keypad or the easy menu-driven configuration structure, Fluidwell is always your first and best choice.
- ✔ Alternative Fluidwell products: 300-Series.
For analog inputs we offer our F-Series and D-Series [batch controllers](#).
For intrinsically safe applications we offer our field mount [F-Series indicators](#).

General information

Introduction

The N410 batch controller distinguishes itself by its user-friendly features: Numerical keypad, clear programming menu structure, easy to read display and simple mounting enclosure. The numerical keypad allows simple and fast changing of the preset batch quantity. Fluidwell stands for simplicity and reliability and it is now available in this customer focused and application driven batch controller.

Display

The unique LCD display provides multiple batch control data at a glance. The main information like actual value, flow rate or batched total are displayed with 7 large digits (14mm, 0.56"). The preset value and units of measure are displayed with 10 smaller segments (8mm, 0.3"). A graphical indication of the batch process and relay status are displayed simultaneously. On-screen engineering units are easily configured in the configuration menu. All values are saved in EEPROM memory. The N410 is standard provided with a bright backlight, which ensures good readings during day and night and it can be adjusted in 6 steps from 0 to 100%.

Configuration

The N410 uses the highly appreciated configuration structure of our F- and D-Series. Each setting is clearly indicated with an alphanumeric description, eliminating confusing abbreviations. Once familiar with an N-series product, you will be able to program all models in all series without a manual. For example: the configuration menu of the (intrinsically safe) F-Series batch controllers operate almost identical to an N410! In other words: Know one, know them all. Operation and configuration is done via the easy-to-operate numerical keypad. All settings are accessed via a simple operator menu that can be passcode protected.

Batch sizes

The preset value of the batched quantity can be programmed fast and easily by the operator via the numerical keypad. Repeating batches are executed, paused and reset easily with a start, hold and reset button.

Flow meter input

The N410 accepts various input signals for volume flow or mass flowmeters, like reed-switch, open collector, NPN, PNP or active 8 / 12 / 24V pulse signals.

Overrun correction

The Fluidwell N410 measures the overrun quantity at the end of every batch. With the automatic overrun correction procedure, the batch is corrected automatically; every run is executed with the highest accuracy.

No-flow monitor

Following the START command, the flowmeter generates a signal. If this fails to come within the programmed time, an alarm is triggered. The batch is interrupted and the latest process values are stored in the memory. At the same time, the cause of the alarm is displayed. Alarm conditions are indicated visibly and can be configured as an alarm output. The No-flow function detects the absence of liquid, an obstruction in the pipeline or a breakdown.

Control, Pulse or Alarm outputs

Three outputs are available with the N410: two field replaceable, heavy duty relays and one transistor output. Relay 1 is fixed as the main batch control relay. Relay 2 and the transistor output can be configured as 1- or 2-stage batch control, alarm or pulse output.

Communication

All processed data and settings can be read and modified through the optional Modbus link (RS232 / RS485).

Power requirements

Two power inputs are available to power the N410 and sensor. A 110 - 230V AC and a 24V DC power supply. Both offer an 8.2, 12 or 24V DC sensor supply to power the sensor.

Enclosures

The N410 has an IP53 / NEMA3 aluminum DIN size front panel and an IP20 GRP back cover. The removable screw terminal connectors on the back-side and the 4 mounting clamps make the N410 very easy to install.

Limited depth clearance



Very easy menu structure



Dimensions enclosures

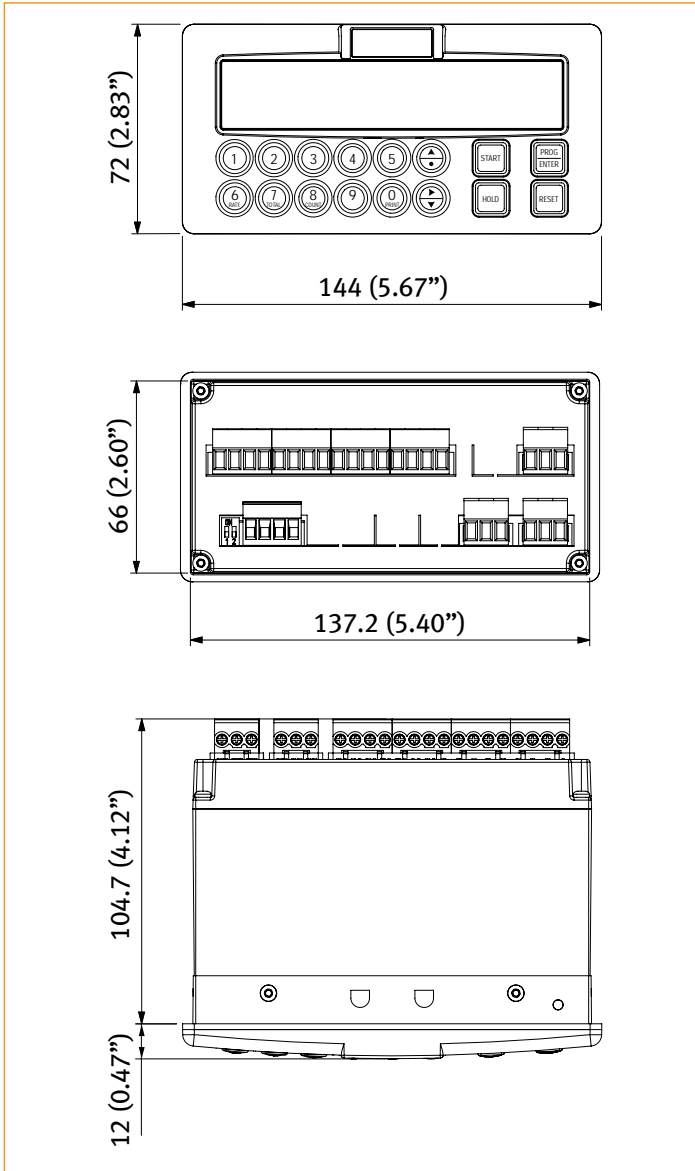

Panel cut-out

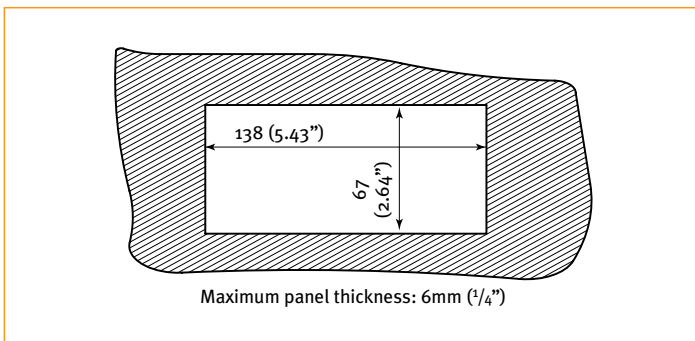

Overview application N410

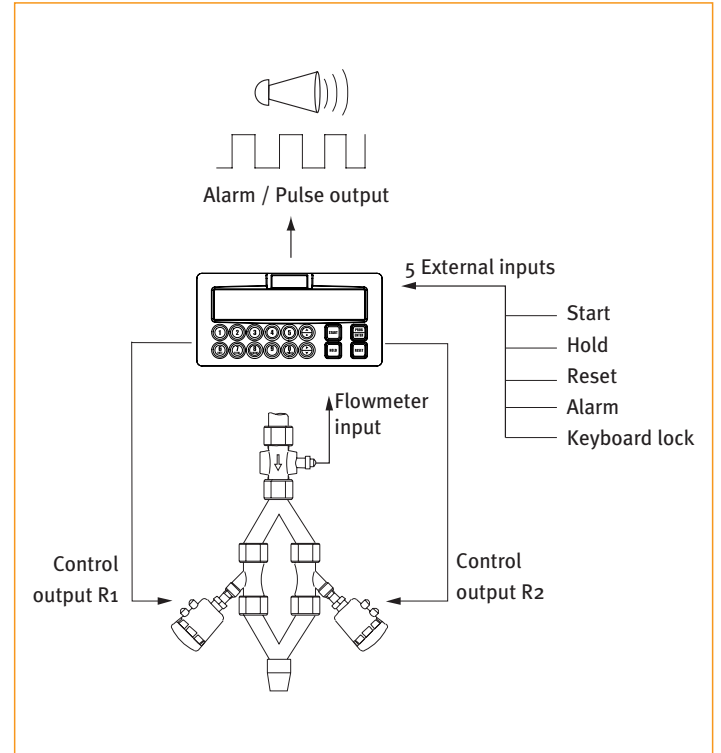

Terminal connections

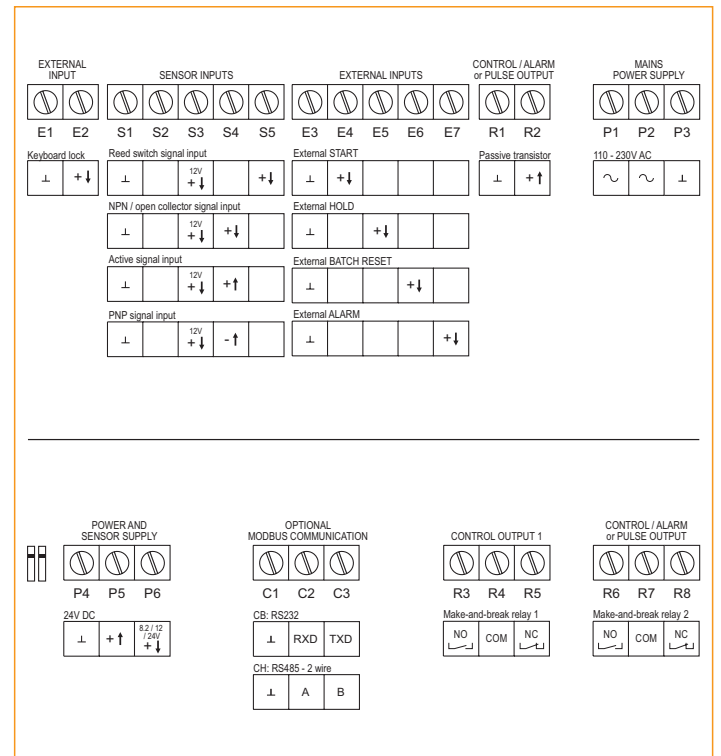

Display example 1:1 - 22 x 116mm (0.87 x 4.57")

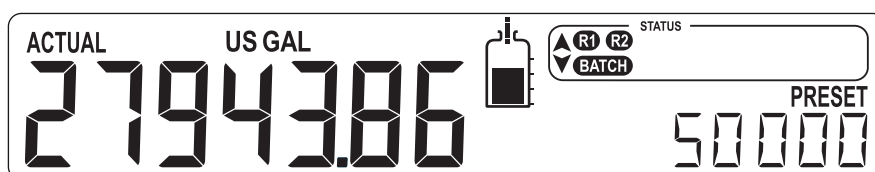

Typical wiring diagram N410-P-CH-OR-PG

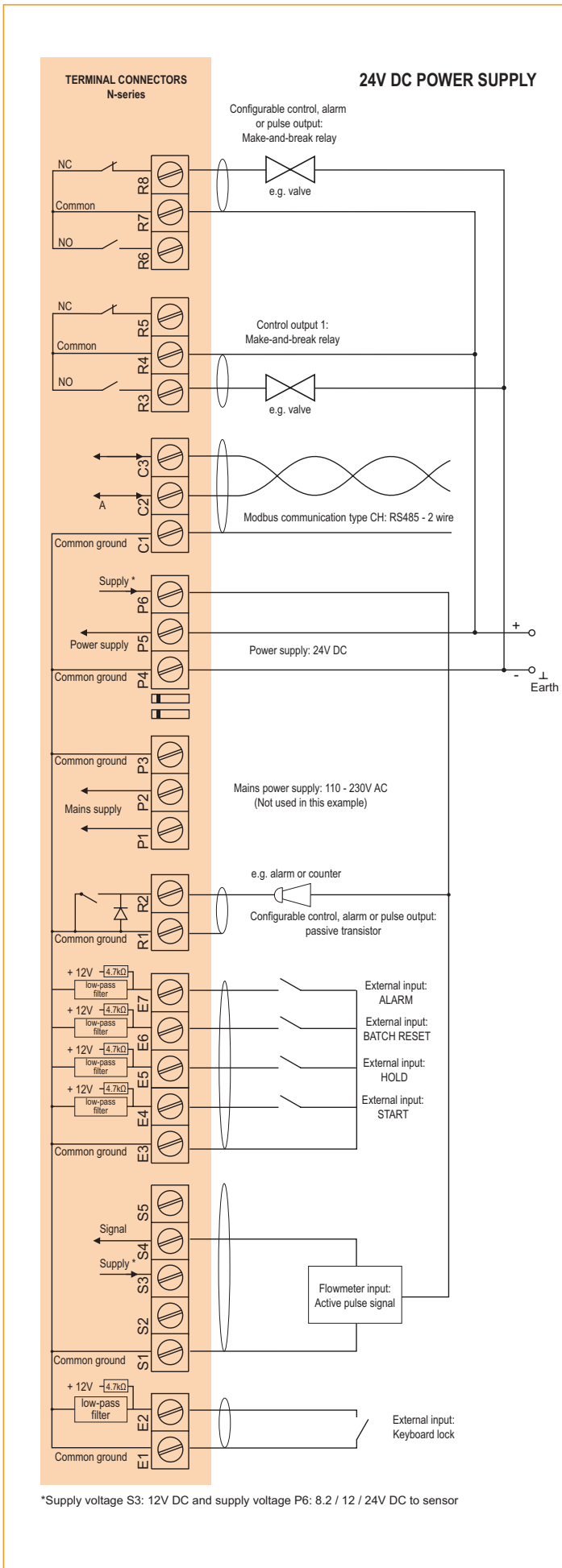

Typical wiring diagram N410-P-CB-OR-PG

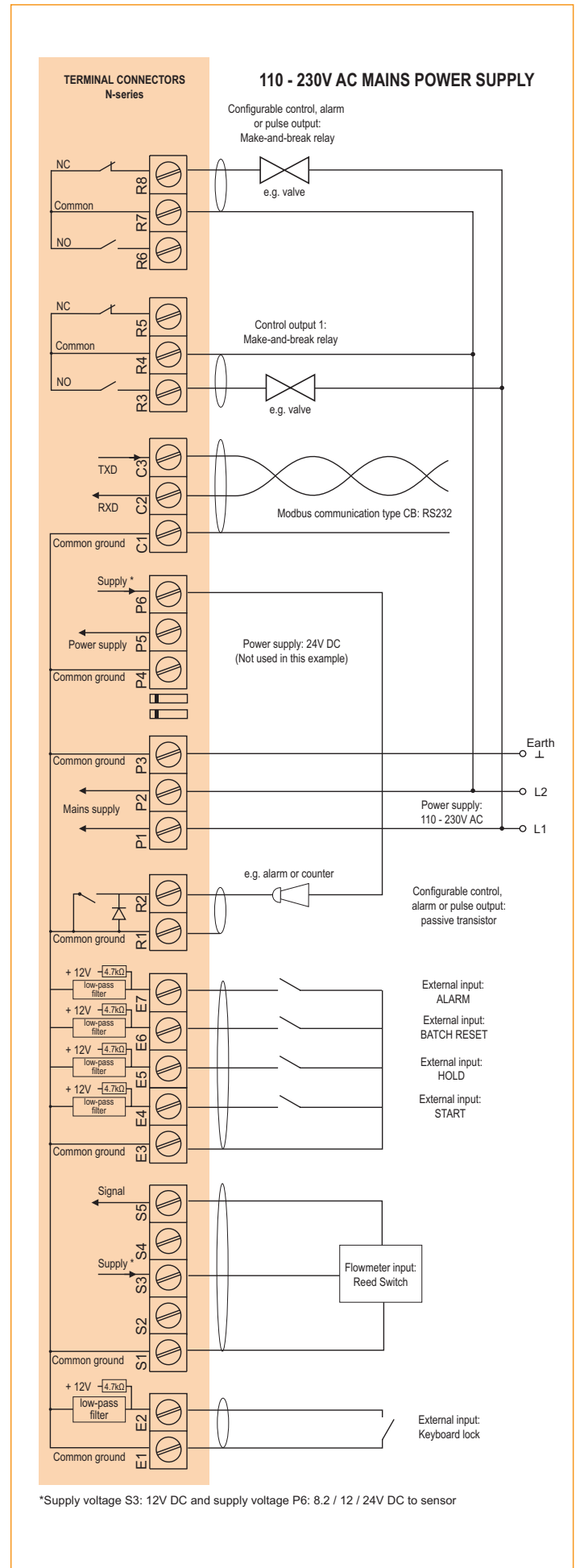

Technical specification

General

Display	
Type	High intensity transfective numeric and alpha-numeric LCD, UV-resistant. White LED backlight. Intensity adjustable from 0 – 100% in steps of 20%. Good readings in full sunlight and in darkness.
Dimensions	22 x 116mm (0.87 x 4.57”).
Digits	Seven 14mm (0.56”) and ten 8mm (0.3”) digits. Various symbols and measuring units.
Refresh rate	8 times/sec.

Enclosure	
General	Die-cast aluminum front panel, GRP back enclosure. Polycarbonate window, silicone gasket; UV stabilized and flame retardant material.
Keypad	Sixteen industrial micro-switch keys; UV-resistant silicone keypad; replaceable front.
Painting	UV-resistant 2-component industrial painting.
Dimension	144 x 72 x 110mm (5.67” x 2.83” x 4.33”) – W x H x D.
Classification	IP53 / NEMA3 at the front side. IP20 at the back side.
Panel cut-out	138 x 67mm (5.43” x 2.64”) W x H.
Weight	650 gram / 1.7 lbs.
Panel thickness	Max. 6mm (¼”).

Operating temperature / humidity	
Temperature	-20°C to +60°C (-4°F to +140°F).
Storage	-40°C to +80°C (-40°F to +176°F).
Humidity	85% non-condensing, relative.

Power requirements	
Type PG	110 - 230V AC. Power consumption max. 10 Watt. 24V DC \pm 10%. Power consumption max. 10 Watt.

Sensor excitation	
Type PG	Terminal S3: 12V DC. Iout max. 30mA. Terminal P6: 8.2 / 12 or 24V DC. Max. 50mA. 8.2V DC, Iout max. 20mA. 12V DC, Iout max. 30mA. 24V DC, Iout max. 75mA.

Terminal connections	
Type	Removable plug-in terminal strip. Wire max. 2.5mm ² .

Data protection	
Type	EEPROM backup of all settings. Backup of running totals every minute. Data retention at least 10 years.
Pass-code	Configuration settings can be pass-code protected.

Directives	
EMC	EN61326-1, EN61000-6-2, EN61000-6-3, FCC 47 CFR part 15.
Low voltage	Compliant ref: EN61010-1.

Signal input

Flowmeter sensor	
Type P	NPN, open collector, reed-switch, PNP or active 8 / 12 / 24V DC pulse signals.
Frequency	Minimum 0Hz - maximum 5kHz for total and flow rate. Maximum frequency depends on signal type and internal low-pass filter. E.g. reed switch with low-pass filter: max. frequency 120Hz.
K-Factor	0.000010 - 9,999,999 with variable decimal position.
Low-pass filter	Available for all pulse signals.
Low Level	0V DC min. to 3V DC max.
High Level	8V DC min. to 24V DC max.
Load impedance	4.7kOhm pull-up to +12V DC.
Current	2.5mA steady state.

External inputs	
Function	Five remote inputs: START, HOLD, RESET, Keypad Lock and External Alarm.
Type	Current sinking.
Logic	Level sensitive.
Low Level	0V DC min. to 3V DC max.
High Level	8V DC min. to 24V DC max.
Load impedance	4.7kOhm pull-up to +12V DC.
Current	2.5mA steady state.
Response	100ms make and break time.

Signal output

Control, alarm or pulse output	
Type OR	<ul style="list-style-type: none">One batch output (always a mechanical relay).Two configurable outputs (one mechanical relay and one transistor): batch / two-stage control / any alarm / scaled pulse output.
Frequency	Max. 500Hz. Pulse length user definable between 1msec up to 10 seconds.
Relays	2 isolated, field replaceable, electro-mechanical relays (NO-NC). Max. switching capacity (resistive load): 8A @ 250V AC / 30V DC Max. switching power (resistive load): 2000VA 240W.
Transistors	One passive transistor output - not isolated. Load max. 50V DC - 300mA.

Communication option	
Function	Reading display information, reading / writing all configuration settings.
Type CB	Modbus RTU - RS232.
Type CH	Modbus RTU - RS485 2-wire.
Speed	1200 - 2400 - 4800 - 9600 baud.
Addressing	Maximum 255 addresses.

Datasheet N410

User friendly batch controller



Reliable

Count on us.

Operational

Operator functions

Functions	<ul style="list-style-type: none"> • Enter a preset value. • Start, hold and stop the batch process. • Total can be reset to zero. • Batch counter can be reset to zero.
Displayed functions	<ul style="list-style-type: none"> • Preset value. • Running batch total or remaining quantity. • Total and accumulated total. • Flow rate. • Batch counter. • Graphical indication progress of the actual batch.
Additional functions	<ul style="list-style-type: none"> • Active overrun correction. • Minimum / maximum preset value.

Preset / Total

Digits	7 digits.
Units	L, m ³ , USGAL, IGAL, ft ³ , bbl, kg, Ton, lb.
Decimals	0 - 1 - 2 or 3.
Note	Total can be reset to zero.

Accumulated total

Digits	10 digits.
Units / decimals	According to selection for preset.
Note	Cannot be reset to zero.

Batch counter

Digits	10 digits.
Note	Counter can be reset to zero.

Flow rate

Digits	7 digits.
Units	L, m ³ , USGAL, IGAL, ft ³ , bbl, kg, Ton, lb.
Decimals	0 - 1 - 2 or 3.
Time units	/sec - /min - /hr - /day.

Ordering information

Standard configuration: N410-P-CX-HB-OR-PG-XX-ZX.

Ordering information: N410	-	_	-C	-HB	-OR	-PG	-XX	-ZX
Flowmeter input signal								
P	NPN, open collector, reed-switch, active pulse signals.							
S	PNP, open collector, reed-switch, active pulse signals.							
Communication								
CB	RS232 communication - Modbus RTU.							
CH	RS485 communication - 2-wire - Modbus RTU.							
CX	No communication.							
Panel mount front enclosure								
HB	Aluminum front panel.							
Outputs								
OR	2 field replaceable, mechanical relays (NO-NC) and 1 passive transistor output.							
Power requirements								
PG	24V DC and 110 - 230V AC, both with sensor supply.							
Hazardous area								
XX	Safe areas only.							
Other options								
ZX	No options.							

