

Overview



The SITRANS F M MAG 1100 is an electromagnetic flow sensor in a compact wafer design designed for flow applications in the process industry.

Benefits

- Sensor sizes: DN 2 to 100 (1/12" to 4")
- Compact wafer design meets EN 1092, DIN and ANSI flange standards
- Corrosion resistant AISI 316 stainless steel sensor housing
- Highly resistant liner and electrodes fitting most extreme process media
- Temperature rating up to 200 °C (392 °F)
- Hose proof IP67/NEMA 4X enclosure rating
- Designed that patented in-situ verification can be conducted. Using SENSORPROM fingerprints.

Application

The main applications of the SITRANS F M electromagnetic flow sensors can be found in the following fields:

- Process industry
- Chemical industry
- Pharmaceutical industry
- Water treatment like e.g. chemical dosing

Design

- Compact or remote mounting possible
- Easy "plug & play" field changeability of transmitter
- Simple on site upgrade to IP68/NEMA 6P terminal box
- Ex ATEX 2G D version
- FM Class I, Div 2

Mode of operation

The flow measuring principle is based on Faraday's law of electromagnetic induction according to which the sensor converts the flow into an electrical voltage proportional to the velocity of the flow.

Integration

The complete flowmeter consists of a flow sensor and an associated transmitter SITRANS F M MAG 5000, 6000 or 6000 I. The flexible communication concept USM II simplifies integration and update to a variety of fieldbus systems such as HART, FOUNDATION Fieldbus H1, DeviceNet, PROFIBUS DP and PA, Modbus RTU/RS 485.

Technical specifications

Version	MAG 1100	MAG 1100 HT (High temperature)
Measuring principle	Electromagnetic induction	Electromagnetic induction
Excitation frequency (Mains supply: 50 Hz/60 Hz)	DN 2 ... 65 (1/12" ... 2½"): 12.5 Hz/15 Hz DN 80, 100 (3", 4"): 6.25 Hz/7.5 Hz	DN 15 ... 50 (½" ... 2"): 12.5 Hz/15 Hz DN 80, 100 (3", 4"): 6.25 Hz/7.5 Hz
Process connection		
Nominal size		
• MAG 1100 (Ceramic)	DN 2 ... DN 100 (1/12" ... 4")	DN 15 ... DN 100 (½" ... 4")
• MAG 1100 (PFA)	DN 10 ... DN 100 (3/8" ... 4")	
Mating flanges	EN 1092-1 (DIN 2501), ANSI B 16.5 class 150 and 300 or equivalent Option: DN 2 ... 10 (1/12" ... 3/8"): G½" / NPT ½" pipe connection adapters	EN 1092-1 (DIN 2501), ANSI B 16.5 class 150 and 300 or equivalent
Rated operating conditions		
<u>Ambient conditions</u>		
Ambient temperature ¹⁾		
• Standard sensor	-40 ... +100 °C (-40 ... +212 °F)	-40 ... +100 °C (-40 ... +212 °F)
• Ex sensor	-20 ... +60 °C (-4 ... +140 °F)	-20 ... +60 °C (-4 ... +140 °F)
• Compact transmitter MAG 5000/6000 ²⁾	-20 ... +60 °C (-4 ... +140 °F)	
• Compact transmitter MAG 6000 I	-20 ... +60 °C (-4 ... +140 °F)	
• Compact transmitter MAG 6000 I Ex	-20 ... +60 °C (-4 ... 140 °F)	
<u>Temperature of medium</u>		
• MAG 1100 (Ceramic)	-20 ... +150 °C (-4 ... +302 °F)	-20 ... +200 °C (-4 ... +392 °F)
• MAG 1100 Ex (Ceramic)	-20 ... +150 °C (-4 ... +302 °F)	-20 ... +180 °C (-4 ... +356 °F)
• MAG 1100 (PFA)	-30 ... +130 °C (-22 ... +266 °F) Suitable for steam sterilization at 150 °C (302 °F)	
<u>Temperature shock</u>		
• MAG 1100 (Ceramic)		
- Duration ≤ 1 min, followed by 10 min rest	<ul style="list-style-type: none"> • DN 2, 3 (1/12", 1/8") No limitations • DN 6, 10, 15, 25: Max. ΔT ≤ 80 °C/min (¼", 3/8", ½", 1": Max. ΔT ≤ 144 °F/min) • DN 40, 50, 65: Max. ΔT ≤ 70 °C/min (1½", 2", 2½"): Max. ΔT ≤ 126 °F/min) • DN 80, 100: Max. ΔT ≤ 60 °C/min (3", 4"): Max. ΔT ≤ 108 °F/min) 	<ul style="list-style-type: none"> • DN 15, 25: Max. ΔT ≤ 80 °C/min (½", 1": Max. ΔT ≤ 144 °F/min) • DN 40, 50: Max. ΔT ≤ 70 °C/min (1½", 2": Max. ΔT ≤ 126 °F/min) • DN 80, 100: Max. ΔT ≤ 60 °C/min (3", 4": Max. ΔT ≤ 108 °F/min)
• MAG 1100 (PFA)	Max. ± 100 °C (212 °F) momentarily	
<u>Operating pressure</u>		
• MAG 1100 (Ceramic)	<ul style="list-style-type: none"> • DN 2 ... 65: 40 bar (1/12" ... 2½"): 580 psi) • DN 80: 37.5 bar (3": 540 psi) • DN 100: 30 bar (4": 435 psi) Vacuum: 1 x 10 ⁻⁶ bar _{abs} (1.5 x 10 ⁻⁵ psi _{abs})	<ul style="list-style-type: none"> • DN 15 ... 50: 40 bar (½" ... 2"): 580 psi) • DN 80: 37.5 bar (3": 540 psi) • DN 100: 30 bar (4": 435 psi) Vacuum: 1 x 10 ⁻⁶ bar _{abs} (1.5 x 10 ⁻⁵ psi _{abs})
• MAG 1100 (PFA)	20 bar (290 psi) Vacuum: 0.02 bar _{abs} (0.3 psi _{abs}) DN 80 ... DN 100: CO ₂ pressure max. 7 bar (101.5 psi)	
<u>Mechanical load (vibration)</u>		
	<ul style="list-style-type: none"> • 18 ... 1000 Hz random in x, y, z, directions for 2 hours according to EN 60068-2-36 • Sensor: 3.17 grms • Sensor with compact MAG 5000/ 6000 mounted transmitter: 3.17 grms • Sensor with compact MAG 6000 I/ 6000 I Ex mounted transmitter: 1.14 grms • For compact installation with the MAG 6000 I, transmitter to be supported to avoid tension on sensor part. 	<ul style="list-style-type: none"> • 18 ... 1000 Hz random in x, y, z, directions for 2 hours according to EN 60068-2-36 • Sensor: 3.17 grms
<u>Enclosure rating (standard)</u>	IP67 to EN 60529 (NEMA 4X), 1 mH ₂ O for 30 min	IP67 to EN 60529 (NEMA 4X), 1 mH ₂ O for 30 min
EMC	2004/108/EC	2004/108/EC

Flow Measurement

SITRANS F M

Flow sensor MAG 1100 and MAG 1100 HT

Version	MAG 1100	MAG 1100 HT (High temperature)
Design		
Weight	See Dimensional drawings	See Dimensional drawings
Material		
<ul style="list-style-type: none"> Enclosure <ul style="list-style-type: none"> MAG 1100 Terminal box <ul style="list-style-type: none"> Standard Option Fixing studs Gaskets <ul style="list-style-type: none"> Standard Option Pipe connection adapters: DN 2, 3, 6 and 10 (1/12", 1/8", 1/4" and 3/8") 	Stainless steel AISI 316L/1.4404 Fibre glass reinforced polyamide (not for Ex) Stainless steel AISI 316/1.4436 Stainless steel AISI 304/1.4301, Number and size to EN 1092-1:2001 EPDM (max. 150 °C, PN 40 (max. 302 °F, 600 psi)) <ul style="list-style-type: none"> Graphite (max. 200 °C, PN 40 (max. 392 °F, 600 psi)) PTFE (max. 130 °C, PN 25 (max. 266 °F, 300 psi)) <ul style="list-style-type: none"> Stainless steel, AISI 316/1.4436 Hastelloy C22/2.4602 PVDF 	Stainless steel AISI 316L/1.4404 Stainless steel AISI 316/1.4436 Stainless steel AISI 304/1.4301, Number and size to EN 1092-1:2001 Graphite (max. 200 °C, PN 40 (max. 392 °F, 600 psi))
Liner		
<ul style="list-style-type: none"> MAG 1100 (Ceramic) MAG 1100 (PFA) 	<ul style="list-style-type: none"> DN 2, 3 (1/12", 1/8"): Zirconium oxide (ZrO₂) (ceramic) DN 6 ... 100 (1/4" ... 4"): Aluminum oxide Al₂O₃ Reinforced PFA (not for Ex) 	DN 15 ... 100 (1/2" ... 4"): Aluminum oxide Al ₂ O ₃
Electrodes		
<ul style="list-style-type: none"> MAG 1100 (Ceramic) MAG 1100 (PFA) 	<ul style="list-style-type: none"> DN10 ... 100 (3/8" ... 4"): Platinum with gold / Titanium brazing alloy DN 2 ... 6 (1/12" ... 1/4"): Platinum DN 10 ... 15 (3/8" ... 1/2"): Hastelloy C276/2.4819 DN 25 ... 100 (1" ... 4"): Hastelloy C22/2.4602 	Platinum with gold / Titanium brazing alloy
Cable entries		
	<ul style="list-style-type: none"> Remote installation 2 x M20 or 2 x 1/2" NPT Compact installation <ul style="list-style-type: none"> MAG 5000/MAG 6000: 4 x M20 or 4 x 1/2" NPT MAG 6000 I: 2 x M25 (for supply/output) MAG 6000 I Ex: 2 x M25 (for supply/output) 	Remote installation 2 x M20 or 2 x 1/2" NPT
Certificates and approvals		
<u>Calibration</u>		
Standard production calibration, calibration report shipped with sensor	Zero-point, 2 x 25 %, 2 x 90 %	Zero-point, 2 x 25 %, 2 x 90 %
Conforms to	<ul style="list-style-type: none"> PED – 97/23/EC³⁾ (Fluid group: Liquid of fluid group 1) CRN (PFA) 	<ul style="list-style-type: none"> PED – 97/23/EC³⁾ CRN (PFA)
<u>Ex approvals</u>		
MAG 1100 (Ceramic)		
<ul style="list-style-type: none"> Ex sensor or Compact with MAG 6000 I Ex Sensor with/without MAG 5000/6000 /6000 I 	ATEX 2G D sensor Ex de ia IIB T3 - T6 FM Class I, Div 2	ATEX 2G D sensor Ex de ia IIB T3 - T6 FM Class I, Div 2
MAG 1100 (PFA)		
<ul style="list-style-type: none"> Sensor with/without MAG 5000/6000/6000 I 	FM Class I, Div 2	
Custody transfer approval (MAG 5000/6000 CT) ²⁾	<ul style="list-style-type: none"> Cold water pattern approval PTB (Germany) Hot water pattern approval PTB (Germany) Other media than water pattern approval- OIML R 117 (Ceramic liner) (Denmark) 	<ul style="list-style-type: none"> Hot water pattern approval PTB (Germany)

¹⁾ Conditions are also dependent on liner characteristics

²⁾ With compact transmitter MAG 5000 CT/6000 CT -20 ... +50 °C (-4 ... +122 °F)

³⁾ For further information on the PED standard and requirements, see page 9/6.

For technical specification for transmitter - see transmitter pages.

Flow Measurement SITRANS F M

Flow sensor MAG 1100 and MAG 1100 HT

Selection and Ordering data	Article No.
Sensor SITRANS F M MAG 1100 EPDM gaskets included	7ME6110- A 0 -
Diameter	
DN 2 (1/12")	1 D
DN 3 (1/8")	1 H
DN 6 (1/4")	1 M
DN 10 (3/8")	1 R
DN 15 (1/2")	1 V
DN 25 (1")	2 D
DN 40 (1 1/2")	2 R
DN 50 (2")	2 Y
DN 65 (2 1/2")	3 F
DN 80 (3")	3 M
DN 100 (4")	3 T
Liner material	
PFA - DN 10 ... 100 (3/8" ... 4") (not for Ex)	1
Ceramic	2
Electrode material	
Hastelloy C (only with PFA liner)	1
Platinum (only with ceramic liner)	2
Transmitter	
Standard sensor for remote transmitter (order transmitter separately)	A
Ex sensor for remote transmitter (order transmitter separately)	B
MAG 6000 I, Aluminum 18 ... 90 V DC, 115 ... 230 V AC	C
MAG 6000 I, Aluminum 18 ... 30 V DC, Ex	D
MAG 6000 I, Aluminum 115 ... 230 V AC, Ex	E
MAG 6000 Polyamide, 11 ... 30 V DC/ 11 ... 24 V AC	H
MAG 6000, Polyamide, 115 ... 230 V AC	J
MAG 5000, Polyamide, 11 ... 30 V DC/ 11 ... 24 V AC	K
MAG 5000, Polyamide, 115 ... 230 V AC	L
Communication	
No communication, add-on possible	A
HART	B
PROFIBUS PA Profile 3 (only MAG 6000/MAG 6000 I)	F
PROFIBUS DP Profile 3 (not for Ex) (only MAG 6000/MAG 6000 I)	G
Modbus RTU/RS 485 (not for Ex) (only MAG 6000/MAG 6000 I)	E
FOUNDATION Fieldbus H1 (only MAG 6000/MAG 6000 I)	J
Cable glands/terminal box	
Metric: Polyamide terminal box or 6000 I compact	1
1/2" NPT: Polyamide terminal box or 6000 I compact	2
Metric: SS terminal box (mandatory for stainless steel MAG 6000 transmitter)	3
1/2" NPT: SS terminal box (mandatory for stainless steel MAG 6000 transmitter)	4

◆ We can offer shorter delivery times for configurations designated with the Quick Ship Symbol ◆. For details see page 9/5 in the appendix.

1) Quick ship only in combination with Ceramic liner

Selection and Ordering data	Order code
Additional information	
Please add "-Z" to Article No. and specify Order code(s) and plain text.	
Customer-specific converter setup	Y20
Tag name plate, stainless steel fixed with SS wire (add plain text)	Y17
Tag name plate, plastic (self adhesive)	Y18
Factory certificate according to EN 10204-2.2	C14
Factory certificate according to EN 10204-2.1	C15
Sensor cables wired (specify cable Article No.)	Y40
Sensor for remote transmitter's junction box potted to IP68 with wired cable (specify cable Article No.) (not for Ex sensors)	Y41
Other postproduction requirements (add desired text)	Y99
Additional calibrations	
• Matched pair - (Standard production calibration where sensor and transmitter is calibrated together)	On request¹⁾
• Customer-specified calibration up to 10 points	On request¹⁾
• Customer-witnessed calibration	On request¹⁾
Any of above calibration	

¹⁾ Ordering On request as dedicated information from the customer on the individual sensors is required. Please fill in the calibration form found on <http://www.automation.siemens.com/mcms/automation/en/sensor-systems/process-instrumentation/Pages/Default.aspx> and send together with the order. (Size dependent restriction on maximum flow rates may apply)

Operating instructions for SITRANS F M MAG 1100

Description	Article No.
Handbook	
• English	A5E02435647

This device is shipped with a Quick Start guide and a CD containing further SITRANS F literature.

All literature is also available for free at: <http://www.siemens.com/flowdocumentation>

Accessories

Description	Article No.
Potting kit for terminal box of flow sensors for IP68/NEMA 6P (not for Ex sensors)	◆ FDK:085U0220



◆ We can offer shorter delivery times for configurations designated with the Quick Ship Symbol ◆. For details see page 9/5 in the appendix.

Flow Measurement

SITRANS F M

Flow sensor MAG 1100 and MAG 1100 HT

Selection and Ordering data	Article No.
Sensor SITRANS F M	
MAG 1100 HT High Temperature Ceramic liner, Platinum electrode, Graphite gaskets included	7 ME 6 1 2 0 - A 2 0 - 2 A
Diameter	
DN 15 (½")	1 V
DN 25 (1")	2 D
DN 40 (1½")	2 R
DN 50 (2")	2 Y
DN 80 (3")	3 M
DN 100 (4")	3 T
Transmitter	
Standard sensor for remote transmitter (order transmitter separately)	A
Ex sensor for remote transmitter (order transmitter separately)	B
Cable glands/terminal box	
Metric: SS terminal box	3
½" NPT: SS terminal box	4

Selection and Ordering data	Order code
Additional information	
Please add "-Z" to Article No. and specify Order code(s) and plain text.	
Customer-specific converter setup	Y20
Tag name plate, stainless steel fixed with SS wire (add plain text)	Y17
Tag name plate, plastic (self adhesive)	Y18
Factory certificate according to EN 10204-2.2	C14
Factory certificate according to EN 10204-2.1	C15
Sensor cables wired (specify cable Article No.)	Y40
Sensor for remote transmitter's junction box potted to IP68 with wired cable (specify cable Article No.) (not for Ex sensors)	Y41
Other postproduction requirements (add desired text)	Y99
Additional calibrations	
• Matched pair - (Standard production calibration where sensor and transmitter is calibrated together)	On request¹⁾
• Customer-specified calibration up to 10 points	On request¹⁾
• Customer-witnessed calibration Any of above calibration	On request¹⁾

¹⁾ Ordering On request as dedicated information from the customer on the individual sensors is required. Please fill in the calibration form found on <http://pi.khe.siemens.de/index.aspx?Nr=17460> and send together with the order. (Size dependent restriction on maximum flow rates may apply)

Operating instructions for SITRANS F M MAG 1100

Description	Article No.
Handbook • English	A5E02435647
This device is shipped with a Quick Start guide and a CD containing further SITRANS F literature.	
All literature is also available for free at: http://www.siemens.com/flowdocumentation	
MAG 5000/6000 transmitters and sensors are packed in separate boxes, the final assembly takes place during installation at the customer's place. MAG 6000 I/MAG 6000 I Ex ATEX 2G D transmitters and sensors are delivered compact mounted from factory. Communication module will be premounted in the transmitter.	
Please use online Product selector to get latest updates.	
Product selector link: www.pia-selector.automation.siemens.com	

Accessories

Description	Article No.
Potting kit for terminal box of flow sensors for IP68/NEMA 6P (not for Ex sensors)	◆ FDK:085U0220



- ◆ We can offer shorter delivery times for configurations designated with the Quick Ship Symbol ◆. For details see page 9/5 in the appendix.

Accessories	Article No.	Accessories	Article No.
for MAG 1100 sensor		for MAG 1100 sensor	
Pipe connection 1/2" external thread		Grounding ring SS	
For DN 2 ... 10 (1/12" ... 3/8") sensor, material: SS 316 2 pipe connections, 2 EPDM gaskets, 12 pcs M4 x 12 screws		Material: AISI 316/1.4436; each set includes: 1 grounding ring ¹⁾ , 3 PTFE gaskets, 1 earth wire, 1 M6 screw	
• 1/2" G, ISO 7-1 tapered thread, SS 316	◆ FDK:083G0080	• DN 2 ... 10 (1/12" ... 3/8")	◆ FDK:083G0686
• 1/2" NPT thread, SS 316	◆ FDK:083G4330	• DN 15 (1/2")	◆ FDK:083G0687
		• DN 25 (1")	◆ FDK:083G0689
For DN 2 ... 10 (1/12" ... 3/8") sensor, material: Hastelloy C 2 pipe connections, 2 PTFE gaskets, 12 pcs M4 x 14 screws		• DN 40 (1 1/2")	FDK:083G0691
• 1/2" G, ISO 7-1 tapered thread	◆ FDK:083G4332	• DN 50 (2")	FDK:083G0692
• 1/2" NPT thread	◆ FDK:083G4331	• DN 65 (2 1/2")	FDK:083G0693
		• DN 80 (3")	FDK:083G0694
		• DN 100 (4")	FDK:083G0695
For DN 2...10 (1/12" ... 3/8") sensor 2 PVDF pipe connections (Max. 70 °C, PN 8 bar/max 158 °F, 116 PSI), 1 grounding ring ¹⁾ , 1 earthing wire, 3 PTFE gaskets, 6 pcs. M4 x 12 and 6 pcs. M4 x 20 screws		Grounding ring (Hastelloy C)	
• 1/2" G, ISO 7-1 tapered thread PVDF incl. grounding ring Hastelloy C22/2.4602	A5E01018395	Material: Hastelloy C22/2.4602; each set includes: 1 grounding ring ¹⁾ , 3 PTFE gaskets, 1 earth wire, 1 M6 screw	
• 1/2" NPT thread PVDF incl. grounding ring Hastelloy C22/2.4602	A5E01018400	• DN 2 ... 10 (1/12" ... 3/8")	◆ FDK:083G3256
		• DN 15 (1/2")	◆ FDK:083G3257
		• DN 25 (1")	◆ FDK:083G3259
		• DN 40 (1 1/2")	◆ FDK:083G3261
		• DN 50 (2")	◆ FDK:083G3262
		• DN 65 (2 1/2")	FDK:083G3263
		• DN 80 (3")	FDK:083G3264
		• DN 100 (4")	FDK:083G3265
EPDM gaskets		Grounding ring (Tantalum)	
Material: EPDM; each set includes: 2 EPDM gaskets, 1 earthing wire, 1 M6 screw, 1 nut, 1 washer, 1 bolt earthing plate		Material: Tantalum; each set includes: 1 grounding ring ¹⁾ , 3 PTFE gaskets, 1 earth wire, 1 M6 screw	
• DN 2 ... 10 (1/12" ... 3/8")	◆ FDK:083G3116	• DN 2 ... 10 (1/12" ... 3/8")	A5E01181599
• DN 15 (1/2")	◆ FDK:083G3117	• DN 15 (1/2")	A5E01181606
• DN 25 (1")	◆ FDK:083G3119	• DN 25 (1")	A5E01181610
• DN 40 (1 1/2")	◆ FDK:083G3121	• DN 40 (1 1/2")	A5E01181613
• DN 50 (2")	◆ FDK:083G3122	• DN 50 (2")	A5E01181615
• DN 65 (2 1/2")	◆ FDK:083G3123	• DN 65 (2 1/2")	A5E01181616
• DN 80 (3")	◆ FDK:083G3124	• DN 80 (3")	A5E01181619
• DN 100 (4")	◆ FDK:083G3125	• DN 100 (4")	A5E01181622
PTFE gaskets		Studs and nuts	
Material: PTFE; each set includes: 2 gaskets, 2 earthing wires, 3 M6 screws (DN 2 ... DN 10: 12 pcs M4 x 14)		for DN 100 PN 25/40, 8 M20 studs, 16 M20 nuts	
• DN 2 ... 10 (1/12" ... 3/8")	◆ FDK:083G0156	Material: AISI 304/1.4305	
• DN 15 (1/2")	◆ FDK:083G0157	• DN 100 (4")	◆ FDK:083G0226
• DN 25 (1")	◆ FDK:083G0159		
• DN 40 (1 1/2")	◆ FDK:083G0161		
• DN 50 (2")	◆ FDK:083G0162		
• DN 65 (2 1/2")	◆ FDK:083G0163		
• DN 80 (3")	◆ FDK:083G0164		
• DN 100 (4")	◆ FDK:083G0165		
Graphite gaskets			
Material: Graphite; conductive, each set includes: 2 gaskets (conductive (can also be used as grounding ring))			
• DN 2 ... 10 (1/12" ... 3/8")	◆ FDK:083G0116		
• DN 15 (1/2")	◆ FDK:083G0117		
• DN 25 (1")	◆ FDK:083G0119		
• DN 40 (1 1/2")	◆ FDK:083G0121		
• DN 50 (2")	◆ FDK:083G0122		
• DN 65 (2 1/2")	◆ FDK:083G0123		
• DN 80 (3")	◆ FDK:083G0124		
• DN 100 (4")	◆ FDK:083G0125		

¹⁾ Thickness of grounding ring is 2 mm (0.08 inch)

◆ We can offer shorter delivery times for configurations designated with the Quick Ship Symbol ◆. For details see page 9/5 in the appendix.

Flow Measurement

SITRANS F M

Flow sensor MAG 1100 and MAG 1100 HT

Dimensional drawings

Sensor MAG 1100, compact/remote

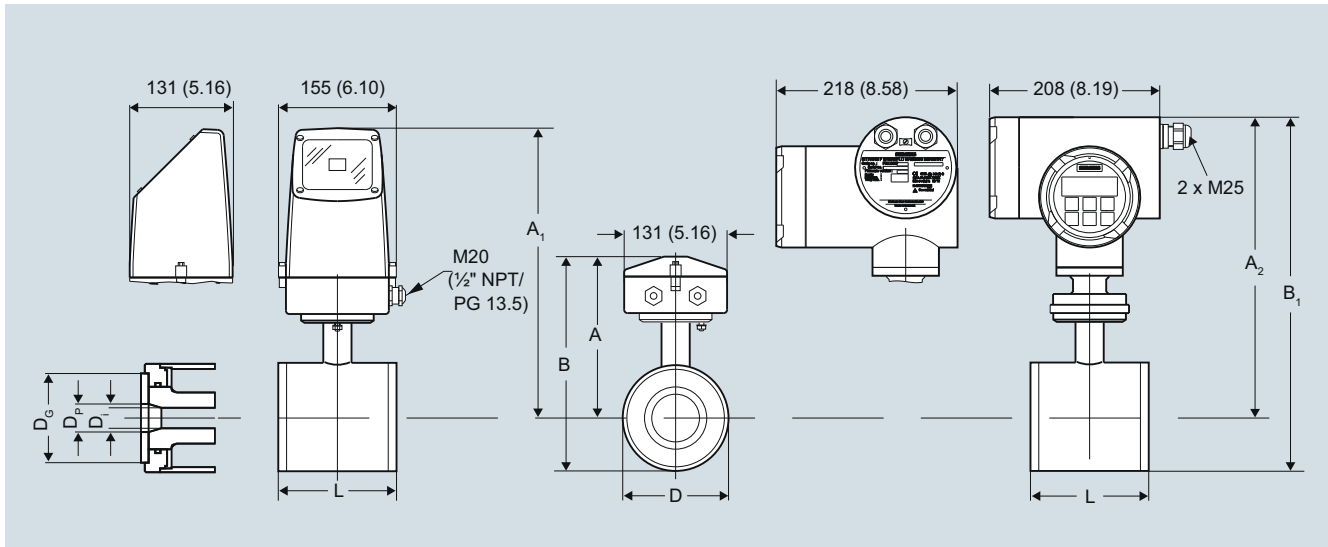

Dimensions in mm (inch)

Important note: For compact installation with MAG 6000 I/Ex - transmitter to be supported to avoid tension on the sensor part

Size DN	A ¹⁾ [mm]	B ¹⁾ [mm]	A ₁ /A ₂ ³⁾ [mm]	B ₁ [mm]	D [mm]	D _i [mm]	D _i (PFA) [mm]	D _p [mm]	D _G [mm]	Weight ²⁾ [kg]
2	161	186	315	340	48.7	2		17.3	34	2.2
3	161	186	315	340	48.7	3		17.3	34	2.2
6	161	186	315	340	48.7	6		17.3	34	2.2
10	161	186	315	340	48.7	10	10	13.6	34	2.2
15	161	186	315	340	48.7	15	16	17.3	40	2.2
25	169	201	323	354	63.5	25	26	28.5	56	2.7
40	179	221	333	375	84.0	40	38	43.4	75	3.4
50	188	239	342	393	101.6	50	50	54.5	90	4.2
65	198	258	351	412	120.9	65	66	68.0	112	5.5
80	204	270	357	424	133.0	80	81	82.5	124	7.0
100	217	296	370	450	159.0	100	100	107.1	150	10.0

Size [inch]	A ¹⁾ [inch]	B ¹⁾ [inch]	A ₁ /A ₂ ³⁾ [inch]	B ₁ [inch]	D [inch]	D _i [inch]	D _i (PFA) [inch]	D _p [inch]	D _G [inch]	Weight ²⁾ [lb]
1/12	6.34	7.33	12.40	13.39	1.92	0.08		0.68	1.34	4.8
1/8	6.34	7.33	12.40	13.39	1.92	0.12		0.68	1.34	4.8
1/4	6.34	7.33	12.40	13.39	1.92	0.24		0.68	1.34	4.8
3/8	6.34	7.33	12.40	13.39	1.92	0.39	0.39	0.53	1.34	4.8
1/2	6.34	7.33	12.40	13.39	1.92	0.59	0.63	0.68	1.57	4.8
1	6.66	7.92	12.72	13.94	2.50	0.98	1.02	1.12	2.20	4.9
1 1/2	7.05	8.70	13.11	14.76	3.31	1.57	1.50	1.71	2.95	7.5
2	7.40	9.41	13.47	15.47	4.00	1.97	1.97	2.15	3.54	9.2
2 1/2	7.80	10.16	13.82	16.22	4.76	2.56	2.60	2.68	4.41	12
3	8.03	10.63	14.06	16.70	5.24	3.15	3.19	3.25	4.88	15
4	8.54	11.65	14.57	17.72	6.26	3.94	3.94	4.22	5.91	22

¹⁾ 14.5 mm/0.571" shorter when the AISI terminal box is used (Ex or high temperature 200 °C (392 °F) version)

²⁾ With transmitter MAG 5000 or MAG 6000 installed, weight is increased by approximately 0.8 kg (1.8 lb).

With MAG 6000 I weight is increased with 5.5 kg (12.1 lb).

³⁾ A₂ is 3 mm (0.12") shorter than A₁

The total build-in length "L" [mm]/[inch] before assembling depends on the gasket selected

Size DN	EPDM		Graphite		PTFE (Teflon)		Without gasket		Earthing ring		
	inch	[mm]	[inch]	[mm]	[inch]	[mm]	[inch]	[mm]	[inch]	[mm]	[inch]
2 ... 10 ¹⁾	1/12 ... 3/8	64	2.52	66	2.60	70	2.75	64	2.52	77	3.03
15	1/2	65	2.56	66	2.60	70	2.75	64	2.52	77	3.03
25	1	80	3.15	81	3.19	85	3.35	79	3.10	92	3.62
40	1 1/2	95	3.74	96	3.78	100	3.94	94	3.70	107	4.21
50	2	105	4.13	106	4.17	110	4.33	104	4.05	117	4.61
65	2 1/2	130	5.12	131	5.15	135	5.31	129	5.05	142	5.60
80	3	155	6.10	156	6.14	160	6.30	154	6.00	167	6.57
100	4	185	7.28	186	7.31	190	7.48	184	7.20	197	7.76

¹⁾ Mounting between two flanges

Sensor MAG 1100 DN 2 ... 10 (1/12" ... 3/8") with adapters

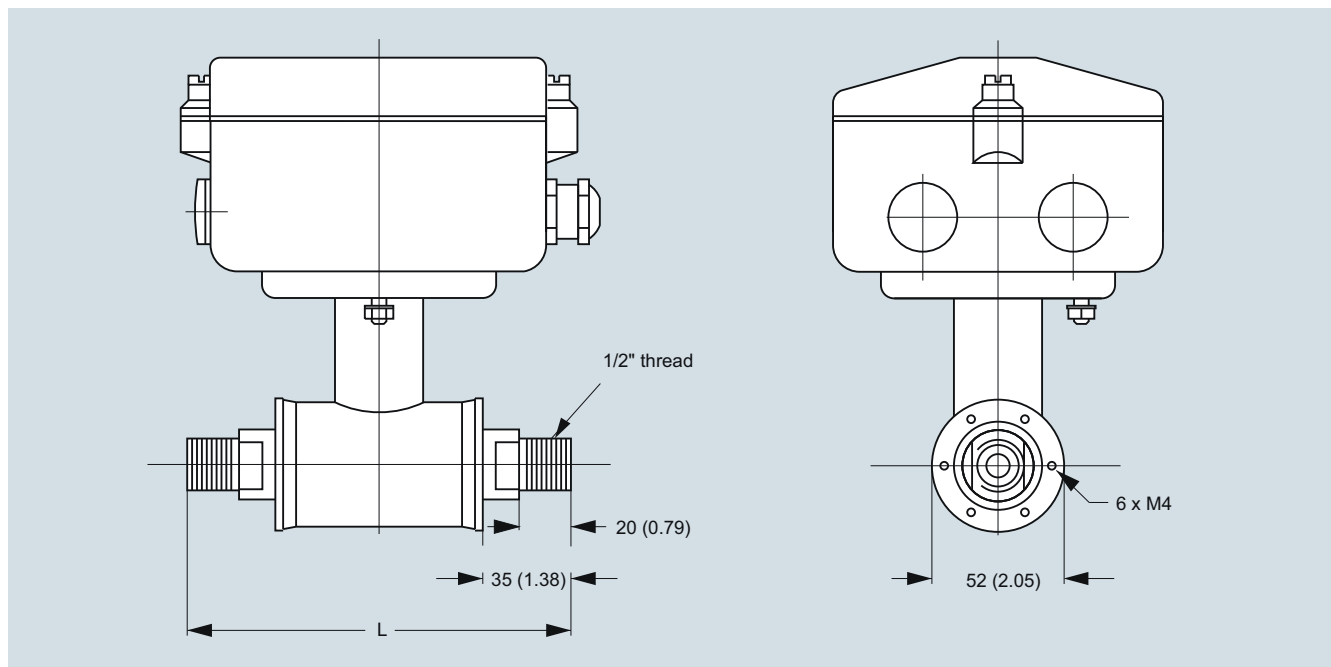

The MAG 1100 DN 2, 3, 6 and 10 (1/12", 1/8", 1/4" and 3/8") are prepared for assembly with the 1/2" pipe connections. Dimensions in mm (inch)

The length "L" varies dependent on the gasket choice.

Stainless steel and Hastelloy pipe connections								PVDF pipe connections	
Without gasket		EPDM		Graphite		PTFE		PTFE	
[mm]	[inch]	[mm]	[inch]	[mm]	[inch]	[mm]	[inch]	[mm]	[inch]
150	5.9	150	5.9	152	6.0	156	6.1	133	5.2

Important note:

For compact installation with the MAG 6000 I, transmitter to be supported to avoid tension on sensor part.