

B-BASIC

FLOWRATE INDICATOR / TOTALIZER

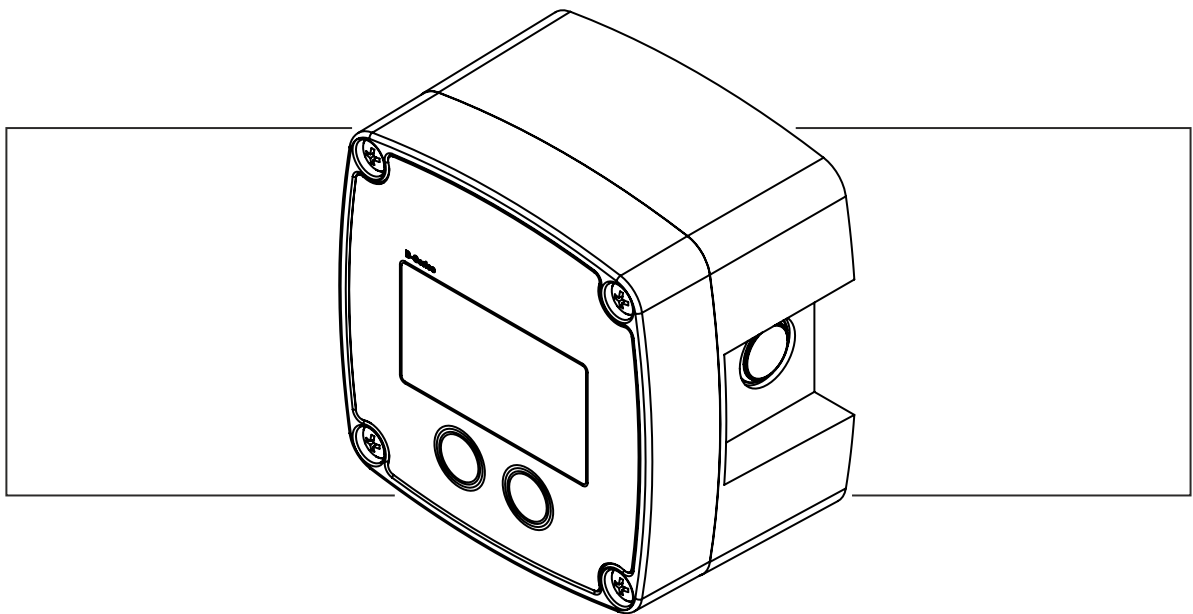

Signal input flowmeter: pulse, NAMUR and coil



SAFETY INSTRUCTIONS



- Any responsibility is lapsed if the instructions and procedures as described in this manual are not followed.
- **LIFE SUPPORT APPLICATIONS:** The B-BASIC is not designed for use in life support appliances, devices, or systems where malfunction of the product can reasonably be expected to result in a personal injury. Customers using or selling these products for use in such applications do so at their own risk and agree to fully indemnify the manufacturer and supplier for any damages resulting from such improper use or sale.
- Electro static discharge does inflict irreparable damage to electronics! Before installing or opening the B-BASIC, the installer has to discharge himself by touching a well-grounded object.
- The B-BASIC must be installed in accordance with the EMC guidelines (Electro Magnetic Compatibility).

DISPOSAL OF ELECTRONIC WASTE



- At the end of its life this product should be disposed of according to the (inter)national regulations regarding waste electronic equipment. If a battery is installed in this product it should be disposed of separately. The separate collection and recycling of your waste equipment will help to conserve natural resources and ensure that it is recycled in a manner that protects the environment.

SAFETY RULES AND PRECAUTIONARY MEASURES

- The manufacturer accepts no responsibility whatsoever if the following safety rules and precautions instructions and the procedures as described in this manual are not followed.
- Modifications of the B-BASIC implemented without preceding written consent from the manufacturer, will result in the immediate termination of product liability and warranty period.
- Installation, use, maintenance and servicing of this equipment must be carried out by authorized technicians.
- Check the mains voltage and information on the manufacturer's plate before installing the B-BASIC.
- Check all connections, settings and technical specifications of the various peripheral devices with the B-BASIC supplied.
- Never open the enclosure while connected to power supplying or consuming devices other than the internal battery supply.
- Open the B-BASIC only if all leads are free of potential.
- Never touch the electronic components (ESD sensitivity).
- Never expose the system to heavier conditions than allowed according to the enclosure classification (see manufacture's plate and chapter 4.2.).
- If the operator detects errors or danger, or disagrees with the safety precautions taken, then inform the owner or principal responsible.
- The local labor and safety laws and regulations must be adhered to.

ABOUT THE OPERATION MANUAL

This operation manual is divided into two main sections:

- The daily use of the B-BASIC is described in chapter 0 "Operational". These instructions are meant for users.
- The following chapters and appendices are exclusively meant for electricians/technicians. These provide a detailed description of all software settings and hardware installation guidance.

This operation manual describes the standard B-BASIC. For additional information, please contact your supplier.

A hazardous situation may occur if the B-BASIC is not used for the purpose it was designed for or is used incorrectly. Please carefully note the information in this operating manual indicated by the pictograms:



A "**warning !**" indicates actions or procedures which, if not performed correctly, may lead to personal injury, a safety hazard or damage of the B-BASIC or connected instruments.



A "**caution !**" indicates actions or procedures which, if not performed correctly, may lead to personal injury or incorrect functioning of the B-BASIC or connected instruments



A "**note !**" indicates actions or procedures which, if not performed correctly, may indirectly affect operation or may lead to an instrument response which is not planned.

WARRANTY AND TECHNICAL SUPPORT

For warranty and technical support for your products, please contact your supplier, visit our internet site www.fluidwell.com or contact us at support@fluidwell.com.

Hardware version : 03.32.07
 Software version : 03.06.xx
 Manual : FW_B-BASIC_v0306-01_EN.docx
 © Copyright 2022 : Fluidwell B.V. - the Netherlands

Information in this manual is subject to change without prior notice. The manufacturer is not responsible for mistakes in this material or for incidental damage caused as a direct or indirect result of the delivery, performance or use of this material.

© All rights reserved. No parts of this publication may be reproduced or used in any form or by any means without written permission of your supplier.

CONTENTS MANUAL

SAFETY INSTRUCTIONS	2
DISPOSAL OF ELECTRONIC WASTE	2
SAFETY RULES AND PRECAUTIONARY MEASURES	2
ABOUT THE OPERATION MANUAL	3
WARRANTY AND TECHNICAL SUPPORT	3
CONTENTS MANUAL	4
1 INTRODUCTION	5
1.1 System description of the B-BASIC	5
2 OPERATIONAL	6
2.1 General information	6
2.2 Control panel.....	6
2.3 Operator information and functions	6
2.4 Operator Alarms.....	7
3 CONFIGURATION	8
3.1 Introduction	8
3.2 Programming SETUP-level.....	8
3.2.1 Entering SETUP-level.....	8
3.2.2 Navigating the SETUP-menu.....	8
3.2.3 Changing configuration settings	9
3.2.4 Returning to OPERATOR-level	10
3.3 Configuration settings	10
3.3.1 SETUP-menu overview.....	10
3.3.2 Menu 1 – Total	11
3.3.3 Menu 2 – Flowrate	11
3.3.4 Menu 3 – Meter (flowmeter).....	12
3.3.5 Menu 4 – Other	12
4 INSTALLATION	13
4.1 General directions.....	13
4.2 Installation / surrounding conditions	13
4.3 Handling the B-Series enclosure	14
4.3.1 Identification.....	14
4.4 Mechanical Installation.....	15
4.4.1 Dimensions – Enclosure	15
4.4.2 Mounting	16
4.5 Electrical Installation	17
4.5.1 Electrical safety.....	17
4.5.2 Sensor supply voltage.....	17
4.6 Terminal connectors	18
4.7 Terminal Connections.....	18
4.7.1 Terminal 1-3: Flowmeter input	18
4.7.2 Terminal 9-10: Power Supply	20
4.7.3 SERVICE-port.....	21
5 MAINTENANCE	22
5.1 General directions.....	22
5.2 instructions for repair	22
5.3 Battery replacement.....	23
5.3.1 Safety instructions.....	23
5.3.2 Disposal of batteries	23
APPENDIX A. TECHNICAL SPECIFICATION	24
APPENDIX B. PROBLEM SOLVING	26
APPENDIX C. DECLARATION OF CONFORMITY	27
INDEX OF THIS MANUAL	28
LIST OF FIGURES	28

1 INTRODUCTION

1.1 SYSTEM DESCRIPTION OF THE B-BASIC

Functions and features

The flowrate / totalizer model B-BASIC is a microprocessor driven instrument designed to show flowrate, total, accumulated total. It is designed to be used in ordinary locations.

This product has been designed with a focus on:

- User-friendliness: easy two button operation.
- Intuitive “Know one, know them all!” configuration menu, saving time, cost and aggravation.
- Good readings in full sunlight and darkness through a bright backlight.
- Mounting flexibility: with a compact and durable IP65 enclosure for field, wall or meter mounting.
- Ability to process most common pulse signals.
- Multiple power supply options to suit any application, including battery supply and 10-30V DC.

Flowmeter input

This manual describes the B-BASIC with a pulse type input from the flowmeter.

One flowmeter with a passive or active pulse, NAMUR or coil signal output can be connected to the B-BASIC. To power the sensor, several options are available.

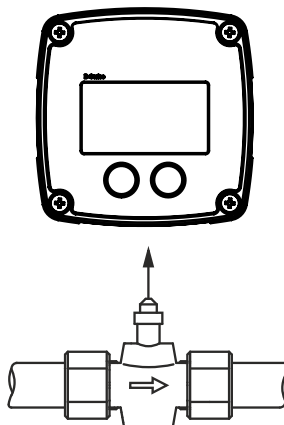

Fig. 1: Typical application for the B-BASIC

Standard outputs

The B-Basic has no outputs. Other models in the B-series and F-series offer extensive functionality. Please consult our website for more information.

Configuration

The B-BASIC has been designed to be implemented in many types of applications. For that reason, a SETUP-level is available to configure your B-BASIC according to your specific requirements. It includes several important features, such as K-Factor, measurement units, signal selection etc. All settings are stored in an EEPROM memory and will not be lost in the event of a power failure or a drained battery.

Display information

The B-BASIC has a LCD with seven 12mm (0.47”) and seven 7mm (0.28”) digits and several symbols. Flowrate is displayed as main information while total and accumulated total will be displayed after pressing the SELECT button.

Backlight

A backlight is standard available (externally powered only).

2 OPERATIONAL

2.1 GENERAL INFORMATION

This chapter describes the daily use of the B-BASIC. This instruction is meant for users / operators.



- The B-BASIC may only be operated by personnel who are authorized and trained by the operator of the facility. All instructions in this manual are to be observed
- Take careful notice of the “Safety rules, instructions and precautionary measures” in the front of this manual.

2.2 CONTROL PANEL

The following keys are available:

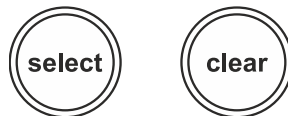

Fig. 2: Control panel

Functions of the keys



SELECT-key

This key is used to:

- SELECT the displayed information, like accumulated total and flowrate.
- gain access to SETUP-level; please read chapter 3.



CLEAR-key

This key is used to CLEAR the value of total.

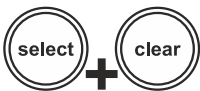

SELECT + CLEAR-key

Press both keys simultaneously to program and save new values or settings.

2.3 OPERATOR INFORMATION AND FUNCTIONS

By default, the B-BASIC will act at Operator level. For the Operator, the following functions are available:

Display process values

On the main screen, the primary process value is shown: Flowrate on the upper-line of the display and the measuring and time unit on the bottom line.



Fig. 3: Example of display information during process

By pressing the SELECT-key, the operator can scroll through the screens showing the various process values. The following table shows the available information:

Display information	Function
MAIN SCREEN	Flowrate
SCREEN 1	Total and reset Total
SCREEN 2	Acc. Total

Display flowrate

Internally, the flowrate is calculated up to 8 times a second, To obtain a readable value, the flowrate shown on the display is updated once every second. Flowrate is shown, based on the configuration settings for Flowrate, with the configured number of decimals. The configured unit and time unit are indicated on the bottom line of the display.

When "-----" is shown, the flowrate value is too high to be displayed.

Display total and accumulated total

A resettable Total and non-resettable Accumulated Total are available. Both totalizers can count up to 9.999.999 before rolling over to zero. The unit and number of decimals are displayed according to the configuration settings for Total.

Clear total

The value for Total can be cleared and reset to zero. This action does not influence the value of Accumulated Total.

To clear Total, press the CLEAR-key when Total is shown on the display and the display will show the flashing text "CLEAR – NO YES". When the CLEAR-key is pressed a second time, Total is reset to zero. To avoid clearing Total at this point, press the SELECT-key or wait for 20 seconds.

2.4 OPERATOR ALARMS

Low-battery alarm

During operation the battery voltage drops. When the battery voltage becomes too low, the text "LOW BAT" will displayed; an indication that the operation become less reliable. When the battery indication is on, install a fresh and new battery (as soon as possible) to keep a reliable operation and indication.

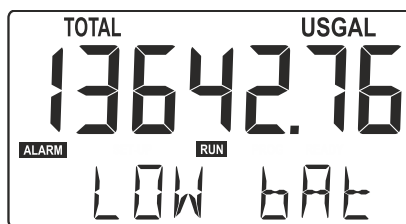

Fig. 4: Example of low-battery alarm.

Alarm

When "ALARM" is displayed, press the SELECT-key to display the reason of the alarm. Please consult Appendix B: problem solving.

3 CONFIGURATION

3.1 INTRODUCTION

This and the following chapters are exclusively meant for electricians and non-operators. In these, an extensive description of all software settings and hardware connections are provided.



- Mounting, electrical installation, start-up and maintenance of the instrument may only be carried out by trained personnel authorized by the operator of the facility. Personnel must read and understand this manual before carrying out its instructions.
- The B-BASIC may only be operated by personnel who are authorized and trained by the operator of the facility. All instructions in this manual are to be observed.
- Ensure that the measuring system is correctly wired up according to the wiring diagrams. The housing may only be opened by authorized personnel.
- Take careful notice of the “Safety rules, instructions and precautionary measures” in the front of this manual.

3.2 PROGRAMMING SETUP-LEVEL



Changing the settings of the B-BASIC may have an influence on the current operation of the device, even when SETUP-level is still active.

Make sure that the unit is not being used for any application when altering the settings.

3.2.1 ENTERING SETUP-LEVEL

Configuration of the B-BASIC is done at SETUP-level, which can be reached at all times while the B-BASIC remains fully operational. At SETUP-level the display will deactivate the **RUN** indicator and activate the **SETUP** indicator.

Use the control panel to access SETUP-level



SELECT-key

To enter SETUP-level, press the SELECT-key for 7 seconds at OPERATOR-level. During this time, the symbol **SETUP** will be flashing.

When SETUP-level is entered, a password might be required to continue. You can enter the PIN by following the procedure for programming values as described in the following paragraphs.



*A password may be required to enter SETUP.
Without this password access to SETUP is denied.*

3.2.2 NAVIGATING THE SETUP-MENU

Each function has a unique menu-number, which is displayed below the **SETUP** indicator at the bottom of the display. The menu-number is a combination of two figures, e.g. 1.2. The first number indicates the function-group and the second number indicates the function. Additionally, each function and function-group is expressed with a keyword.

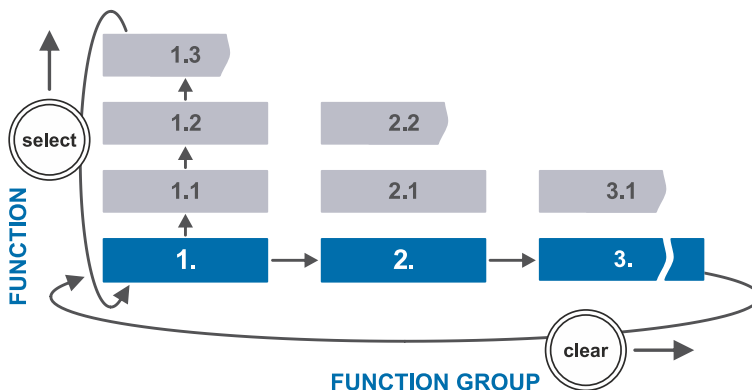

Fig. 5: SETUP-menu matrix structure

Use the control panel to navigate the SETUP-menu



SELECT-key

This key is used to select the next function in the list (e.g. 1 → 1.1 → 1.2 → 1). When the top of the list is reached, it will wrap around and return to the function group selection.



CLEAR-key

This key is used to select the previous function in the list (e.g. 1.2 → 1.1 → 1 → 2). When the bottom of the list is reached, it will return to the function group selection. When only a function group is selected (and no function), this key is used to scroll to the next function group. (e.g. 1 → 2 → 3 → 1).

3.2.3 CHANGING CONFIGURATION SETTINGS

After selecting a function in the SETUP-menu, a new value can be programmed using the control panel. A function either contains a value (a number with optionally a decimal point, e.g. 123.45) or a list with items (e.g. Disable – Enable).

For each function that needs to change, navigate to that function and follow the steps indicated below. During the programming sequence, the display will activate the **PROG** indicator.



Note !

When programming new values, alterations will only be set after the SELECT- and CLEAR-keys have been pressed simultaneously to confirm the new value! (STEP 3)

Step 1: Starting the programming sequence

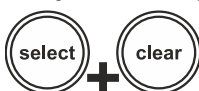

SELECT + CLEAR-key

When a function is selected at SETUP-level, press both keys simultaneously to start the programming sequence.

Step 2a: Changing a value



SELECT-key

This key is used to increment the selected digit or to select the next position of the decimal point.



CLEAR-key

This key is used to select the next digit or to select the previous position of the decimal point.

Step 2b: Changing the selected item in a list



SELECT-key

This key is used to select the next item in the list (e.g. Disable → Enable). At the end of the list, the selection will wrap around to the first selection.



CLEAR-key

This key is used to select the previous item in the list (e.g. Enable → Disable). At the bottom of the list, the selection will wrap around to the last selection.

Step 3: Finishing the programming sequence

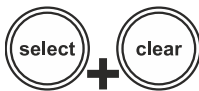

SELECT + CLEAR-key

During the programming sequence, pressing both keys simultaneously is used to confirm the new value and return to SETUP-level. To cancel the operation, wait for 20 seconds: the programming sequence is cancelled and the former value is reinstated.

3.2.4 RETURNING TO OPERATOR-LEVEL

When all settings are configured correctly, the unit can be returned to OPERATE-level. Please keep a record of all settings for later reference.

Use the control panel to return to OPERATE-level



SELECT-key

In order to return to the operator level, press the SELECT-key for three seconds. When no keys are pressed for 2 minutes, SETUP-level will be left automatically. The display will deactivate the **SETUP** indicator and activate the **RUN** indicator.

3.3 CONFIGURATION SETTINGS

All settings of the B-BASIC can be set via the control panel and the SETUP-menu. Additionally, configuration of the B-BASIC can be done using a PC with our free of charge Remote Configuration Tool, which allows you to setup the configuration as desired, up- or download the settings to the device and print a hardcopy for each product.

The connection between the B-BASIC and the PC is made by means of the service port and a special communications cable that can be ordered separately. This is described in section 4.7.4: Service-port.

The Remote Configuration Tool software package can be downloaded from our website at www.fluidwell.com/software and installed on a Microsoft Windows PC using the installation program. The installation also contains a Quickstart manual which gives detailed instructions on how to achieve a successful connection between PC and device.

3.3.1 SETUP-MENU OVERVIEW

1	TOTAL	
1.1	UNIT	L – m3 – kg – lb – GAL – USGAL – bbl – (no unit)
1.2	DECIMALS	0 – 0.1 – 0.02 – 0.003
1.3	K-FACTOR	0.000010 – 9999999
1.4	K-FACTOR DECIMALS	0 – 0.1 – 0.02 – 0.003 – 0.003 – 0.0004 – 0.00005 – 0.000006
2	RATE (flowrate)	
2.1	UNIT	mL – L – m3 – g – kg – ton – GAL – bbl – lb – cf – (no unit)
2.2	TIME	/sec – /min – /hour – /day
2.3	DECIMALS	0 – 0.1 – 0.02 – 0.003
2.4	K-FACTOR	0.000010 – 9999999
2.5	K-FACTOR DECIMALS	0 – 0.1 – 0.02 – 0.003 – 0.003 – 0.0004 – 0.00005 – 0.000006
3	METER (flowmeter)	
3.1	SIGNAL	COIL – REED – NPN – PNP – NAMUR
4	OTHER	
4.1	MODEL	BASIC21
4.2	SOFTWARE VERSION	03.06.xx
4.3	SERIAL NO	xxxxxxx
4.4	PIN	0000 – 9999
4.5	BL BACKLIGHT	off – on

3.3.2 MENU 1 – TOTAL



Note !

*Total and flowrate are configured independently.
Both have their own K-factor and measurement unit.*

Example: Calculating the K-factor.

To manually calculate the K-factor to enter for total or flowrate, follow this example:

Assume that the flowmeter generates 65.231 pulses per US gallon and the required measurement unit is cubic foot / ft³. A cubic foot consists of 7.48052 gallon which implies 487.9618 pulses per cubic feet. So, the K-Factor to enter is 487.9618.

1 TOTAL		
1.1	UNIT	This setting determines the measurement unit for (Accumulated) Total. The following can be selected: L – m3 – kg – LB – GAL – USGAL – bbl – (no unit).
1.2	DECIMALS	The decimal point determines for Total and Accumulated Total the number of digits following the decimal point. The following can be selected: 0 – 0.1 – 0.02 – 0.003
1.3	K-FACTOR	With the Total K-Factor, the flowmeter pulse signals are converted to a total unit. The Total K-Factor is based on the number of pulses generated by the flowmeter per selected measurement unit (SETUP 1.1). Use SETUP 1.4 to set the decimal point. The more accurate the Total K-Factor, the more accurate the functioning of the system will be.
1.4	K-FACTOR DECIMALS	This decimal point determines for K-Factor (SETUP 1.3) the number of digits following the decimal point. The following can be selected: 0 – 0.1 – 0.02 – 0.003 – 0.003 – 0.0004 – 0.00005 – 0.000006

3.3.3 MENU 2 – FLOWRATE

2 FLOWRATE		
2.1	UNIT	This setting determines the measurement unit for flowrate. The following can be selected: mL – L – m3 – g – kg – ton – GAL – bbl – lb – cf – none
2.2	TIME	The flowrate can be calculated per /sec - /min - /hour - /day.
2.3	DECIMALS	This setting determines for flowrate the number of decimals. The following can be selected: 0 – 0.1 – 0.02 – 0.003
2.4	K-FACTOR	With the Flowrate K-factor, the flowmeter pulse signals are converted to a flowrate unit. The Flowrate K-factor is based on the number of pulses generated by the flowmeter per selected measurement unit (SETUP 2.1). The more accurate the K-factor, the more accurate the functioning of the system will be. Use SETUP 2.5 to set the decimal point. The more accurate the Total K-Factor, the more accurate the functioning of the system will be.
2.5	K-FACTOR DECIMALS	This decimal point determines for K-Factor (SETUP 2.4) the number of digits following the decimal point. The following can be selected: 0 – 0.1 – 0.02 – 0.003 – 0.003 – 0.0004 – 0.00005 – 0.000006

3.3.4 MENU 3 – METER (FLOWMETER)

3		METER (flowmeter)			
3.1	SIGNAL	The B-BASIC is able to handle several types of input signal. The type of flowmeter pickup / signal is selected with SETUP 3.1.			
	TYPE OF SIGNAL	EXPLANATION	RESISTANCE	FREQ. / mVpp	REMARK
	NPN	NPN input	100 k Ω pull-up	max. 6 kHz.	(open collector)
	REED	Reed-switch input	1 M Ω pull-up	max. 120 Hz.	
	PNP	PNP input	47 k Ω pull-down	max. 6 kHz.	
	NAMUR	NAMUR input	820 Ω pull-down	max. 4 kHz.	External power required
	COIL	Coil input	-	min. 30 mVpp	-

3.3.5 MENU 4 – OTHER

4		OTHER
4.1	MODEL	For support and maintenance it is important to have information about the characteristics of the B-BASIC. Your supplier will ask for this information in the case of a serious breakdown or to assess the suitability of your model for upgrade considerations.
4.2	SOFTWARE VERSION	
4.3	SERIAL NO.	
4.4	PIN	All SETUP values can be password protected. This protection is disabled with value 0000 (zero). A 4 digit PIN can be programmed, for example 1234.
4.5	BL BACKLIGHT	This submenu is used to switch the backlight on or off. Due to a lack of sufficient power, the backlight does not come on at battery power only.

4 INSTALLATION

4.1 GENERAL DIRECTIONS



Caution !

- Mounting, electrical installation, start-up and maintenance of this instrument may only be carried out by trained personnel authorized by the operator of the facility. Personnel must read and understand this Operating Manual before carrying out its instructions.
- The B-BASIC may only be operated by personnel who are authorized and trained by the operator of the facility. All instructions in this manual are to be observed.
- Ensure that the measuring system is correctly wired up according to the wiring diagrams. Protection against accidental contact is no longer assured when the housing cover is removed or the panel cabinet has been opened (danger from electrical shock). The housing may only be opened by trained personnel.
- Take careful notice of the “Safety rules, instructions and precautionary measures” at the front of this manual.

4.2 INSTALLATION / SURROUNDING CONDITIONS

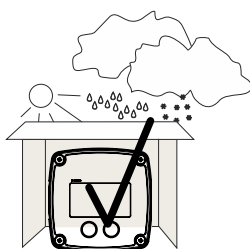
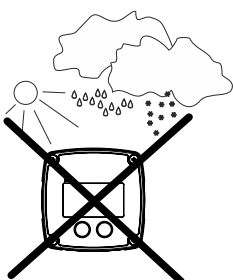

Take the relevant IP classification of the enclosure into account (see identification plate). Even an enclosure rated for IP67 / TYPE 4(X) should NEVER be exposed to strongly varying (weather) conditions.

When used in very cold surroundings or varying climatic conditions, inside the instrument case, take the necessary precautions against moisture.

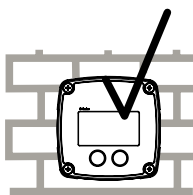
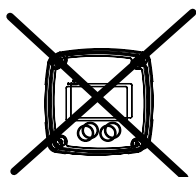

Mount the B-BASIC on a solid structure to avoid vibrations.

Relative humidity:	< 90% RH
Outdoor use:	suitable for outdoor use
IP and NEMA rating:	IP65, NEMA TYPE 4X
Supply voltage fluctuation:	+/- 10% unless stated otherwise
Means of protection:	Class II
Over-voltage category:	II
Pollution degree:	2 (internal environment), 3 (external environment)
Ambient temperature:	-20 °C to +60 °C, -4 °F to + 140 °F
Altitude:	up to 2000 m

4.3 HANDLING THE B-SERIES ENCLOSURE

4.3.1 IDENTIFICATION

Identification label

To identify your B-Series device, all enclosures have a weatherproof identification label placed on the outside of the unit.

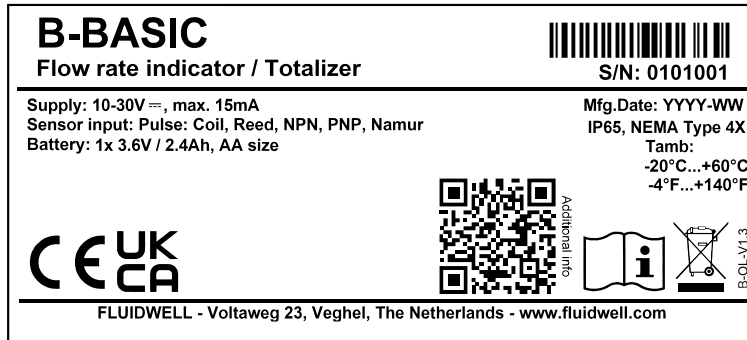

Fig. 6: Example external label with general data.

Installation label

A second label is located on the inside and shows additional installation data.

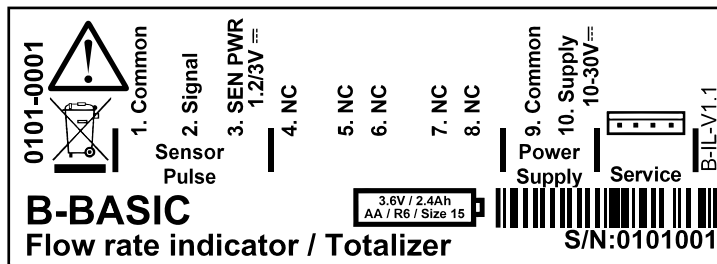
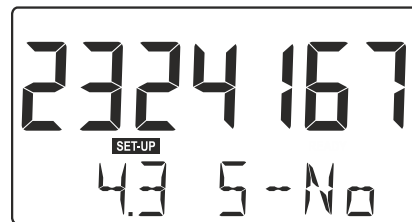

Fig. 7: Example internal label with terminal information.

Serial number and year of production

The serial number can be reviewed on the identification label or in SETUP-menu Others.

The production date is shown on the identification label.



4.4 MECHANICAL INSTALLATION

4.4.1 DIMENSIONS – ENCLOSURE

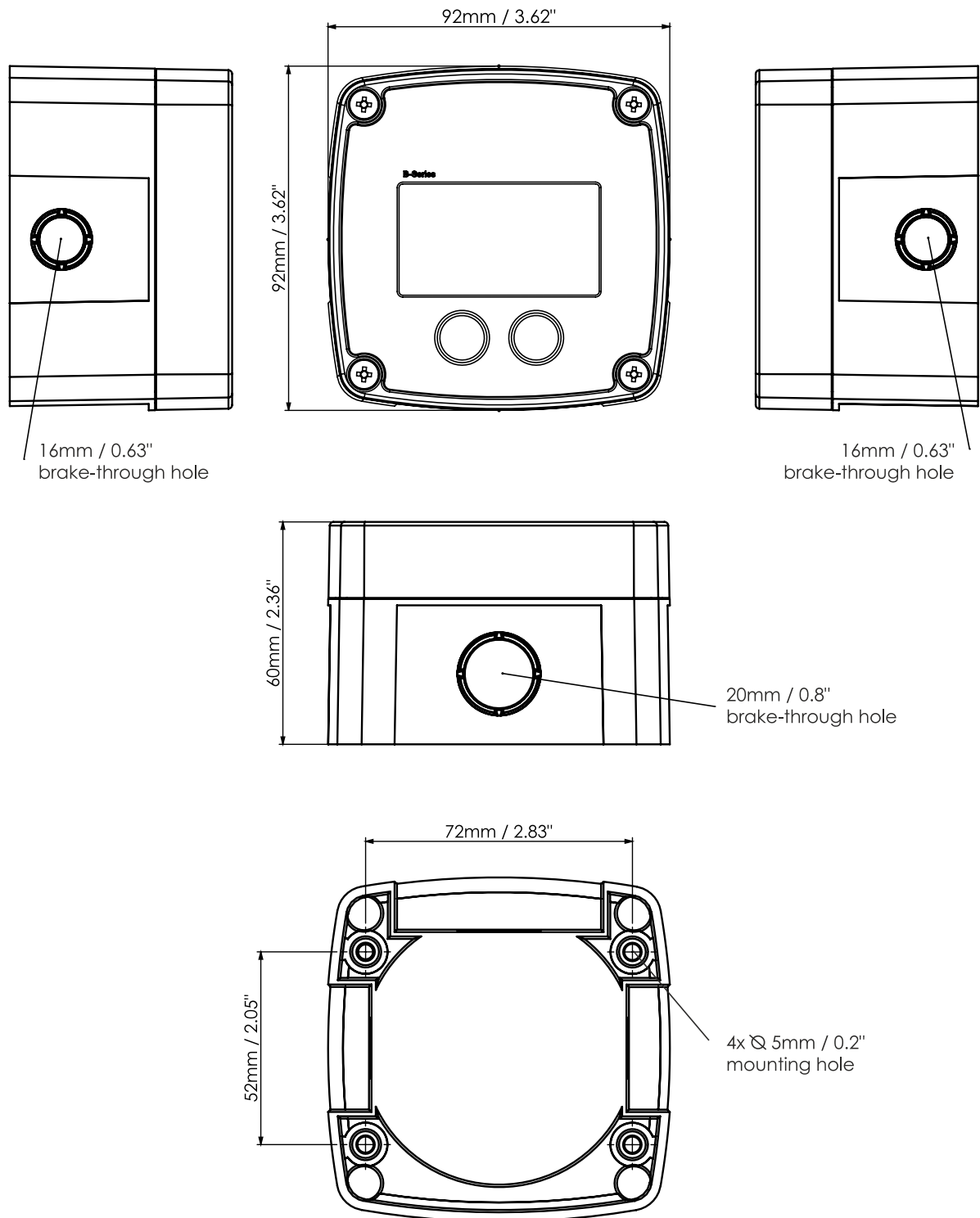
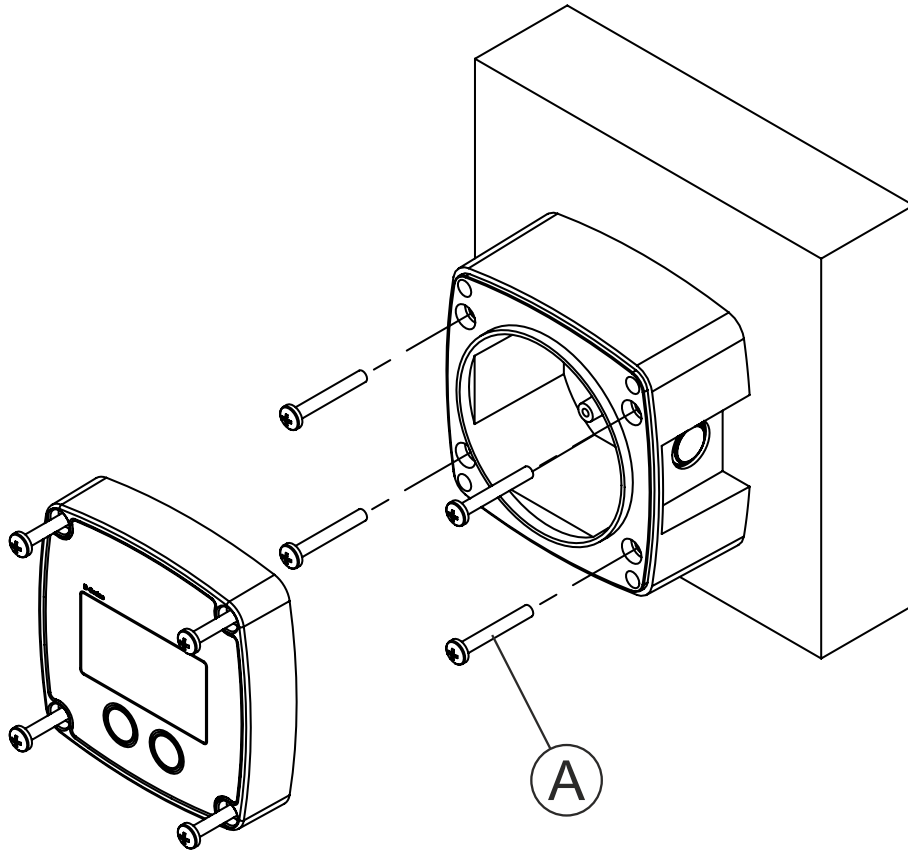

Fig. 8: Dimensions enclosure

4.4.2 MOUNTING

Wall mounting

The enclosure can be wall mounted with screws using the four available mounting holes.



A: 4x screw / bolt:

- Head diameter: 6-8mm / 0.24"- 0.31"
- Shaft diameter: maximum 5mm / 0.2"
- Shaft length: minimum 50mm / 2"
- Use the correct plugs if applicable

Note: The rear-enclosure part can be rotated in steps of 90°, enabling cable entry from any side.

Fig. 9: Installation – Wall mounted

Sensor mounting

The enclosure can be mounted on a sensor by using the mounting hole at the bottom and a lock nut.

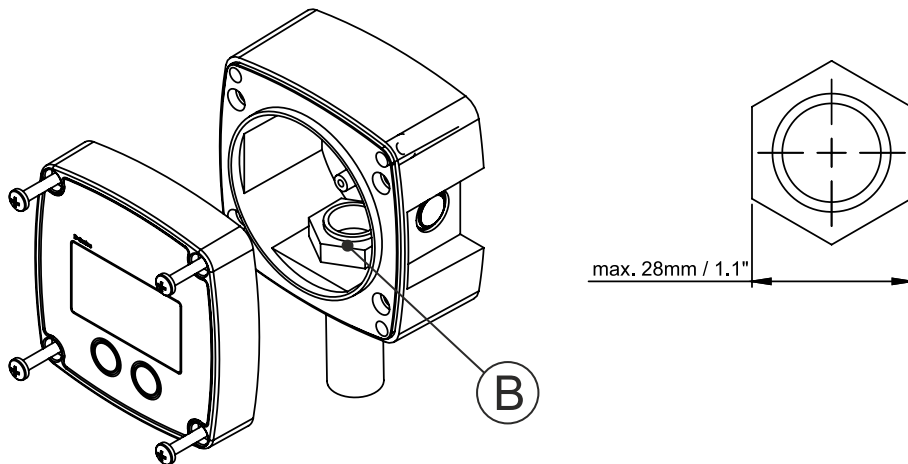

B: Tube diameter: max. 20mm / 0.79". Max. nut height 25mm / 1"

Fig. 10: Installation – Sensor mounted

4.5 ELECTRICAL INSTALLATION



DO NOT OPEN AN INSTALLED ENCLOSURE WHEN CIRCUITS ARE ALIVE.



- Electro static discharge does inflict irreparable damage to electronics! Before installing or opening the B-BASIC, the installer has to discharge himself by touching a well-grounded object.
 - The B-BASIC must be installed in accordance with the EMC guidelines (Electro Magnetic Compatibility).
-
- Use (separate) cable glands with effective IP65 (or better) seals for all wires.
 - For unused cable entries, fit blind plugs with effective IP65 (or better) seals.
 - Use effective screened cable for the input/output signals and provide grounding of its screen to the “⊥” terminal (for isolated signals the corresponding – terminal) or at the external device itself, whichever is appropriate to the application. Be careful not to create ground loops!
 - The cable entry plugs mounted into the enclosure shall comply with the requirements of the type of protection used.

4.5.1 ELECTRICAL SAFETY

- In case this instrument is connected to a supply by means of a permanent connection a switch or circuit-breaker shall be included in the installation. This shall be in close proximity to the equipment and within easy reach of the operator. It shall be marked as the disconnecting device for the equipment. Furthermore, a protective over-current device with a maximum rating of 0.5A (e.g. fuse or circuit breaker) must be inserted in the positive supply line in safe area.
- The external power supply must be an approved ELV source, insulated from AC mains by double / reinforced insulation per IEC 61010-1. All other inputs and outputs shall at least be reinforced insulated from mains.
- The installation must comply with (inter)national requirements and local ordinances. Within the United States all field wiring must conform to the National Electric Code, NFPA 70. Within Canada all field wiring must conform to the Canadian Electrical Code for installations within Canada.

4.5.2 SENSOR SUPPLY VOLTAGE

Terminal 3: Reference voltage: 1.2V DC - 3.2V DC

Terminal 3 provides a reference voltage of 3.2 V DC (coil signals 1.2V) which functions as a limited supply voltage for the signal output of the flowmeter.



Note !

This voltage MAY NOT be used to power the flowmeters electronics, converters etc, as it will not provide adequate sustained power ! All energy used by the flowmeters pick-up will directly influence the battery life-time. It is strongly advised to use a “zero power” pickup such as a coil or reed-switch when operating without external power. It is possible to use some low power NPN or PNP output signals, but the battery life time will be significantly reduced (consult your distributor).

4.6 TERMINAL CONNECTORS

The following terminal connectors are available:

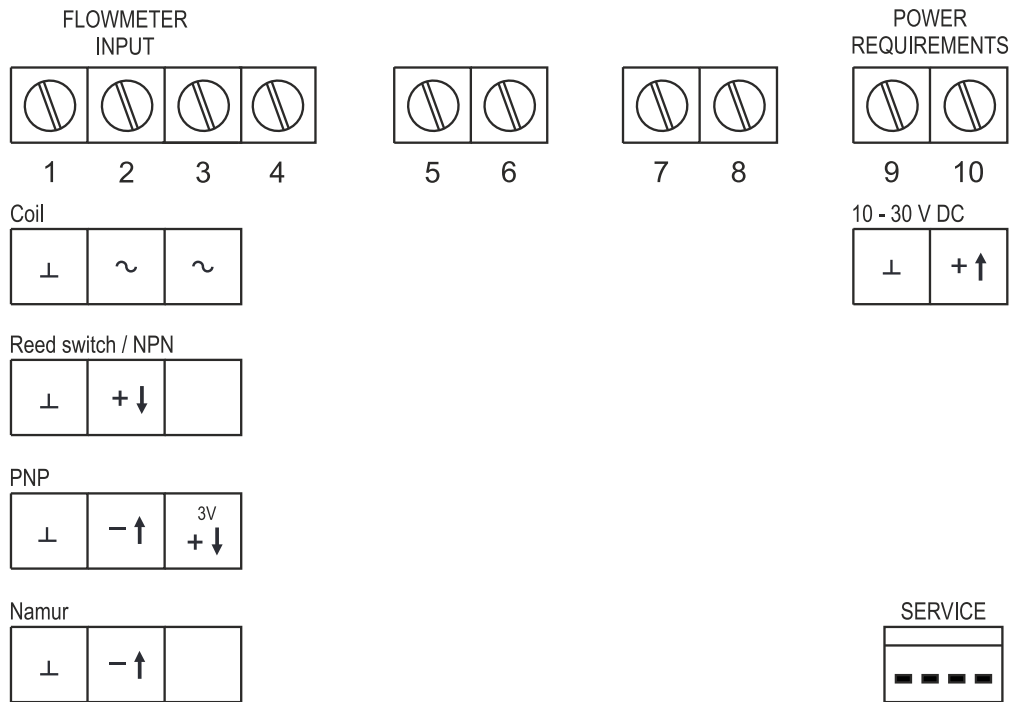

Fig. 11: Terminal connectors B-BASIC

4.7 TERMINAL CONNECTIONS

4.7.1 TERMINAL 1-3: FLOWMETER INPUT

Two basic types of flowmeter signals can be connected to the unit: pulse or sine-wave (coil). The screen of the signal wire must be connected to the common ground terminal (unless earthed at the sensor itself).

The sensor output of the flowmeter should match with the selected flowmeter input signal at SETUP 3.1. See paragraph 3.3.4 for more information.

Sine-wave signal (Coil)

The B-BASIC is suitable for use with flowmeters which have a coil output signal. The minimum sensitivity level is 30mVpp.

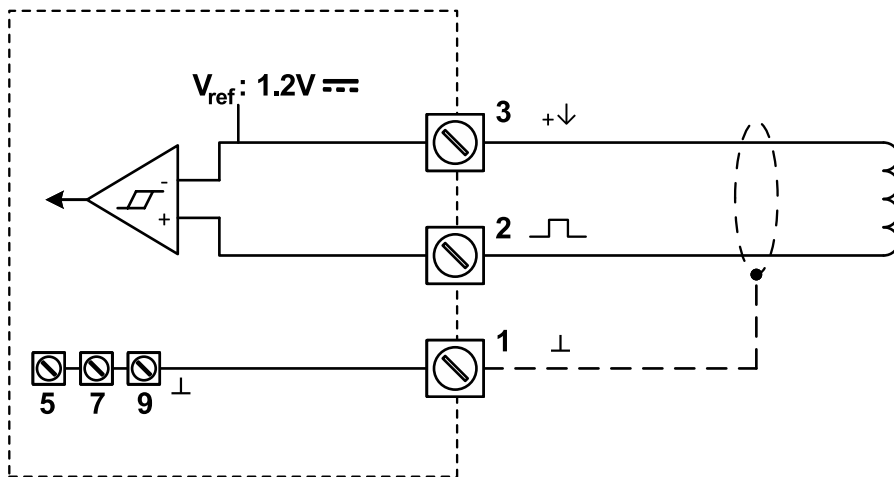

Fig. 12: Terminal connections – Coil signal input

Pulse-signal NPN

The B-BASIC is suitable for use with flowmeters which have a NPN output signal. For reliable pulse detection, the signal should be above 1.4V or below 1.0V under all circumstances. It is advised to use a sensor which is normally open and is closed for a small time (less power consumption).

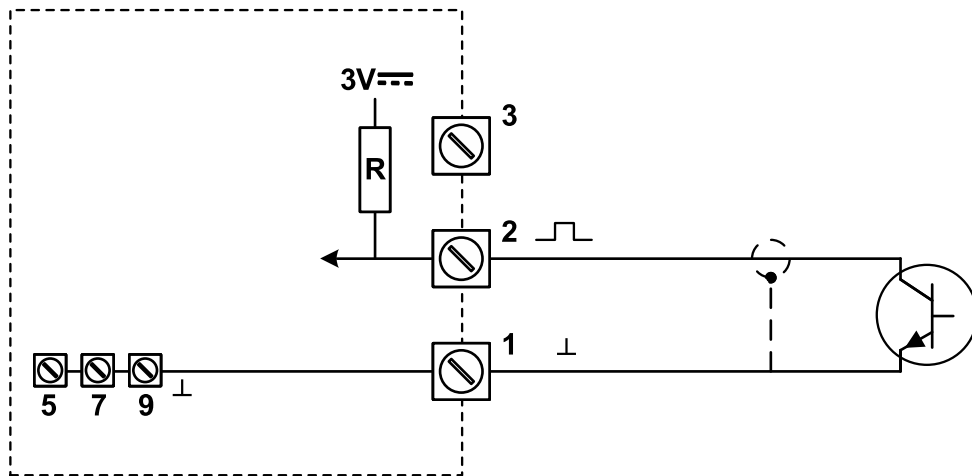

Fig. 13: Terminal connections – NPN signal input

Pulse-signal PNP

The B-BASIC is suitable for use with flowmeters which have a PNP output signal. 3.0V is offered on terminal 3 which has to be switched by the sensor to terminal 2 (SIGNAL). For reliable pulse detection, the signal should be above 1.4V or below 1.0V under all circumstances. It is advised to use a sensor which is normally open and is closed for a small time (less power consumption). In case of an active signal, the maximum voltage is 30V DC.

Terminal 4 can offer a sensor supply voltage of 8.2V DC with external power supply.

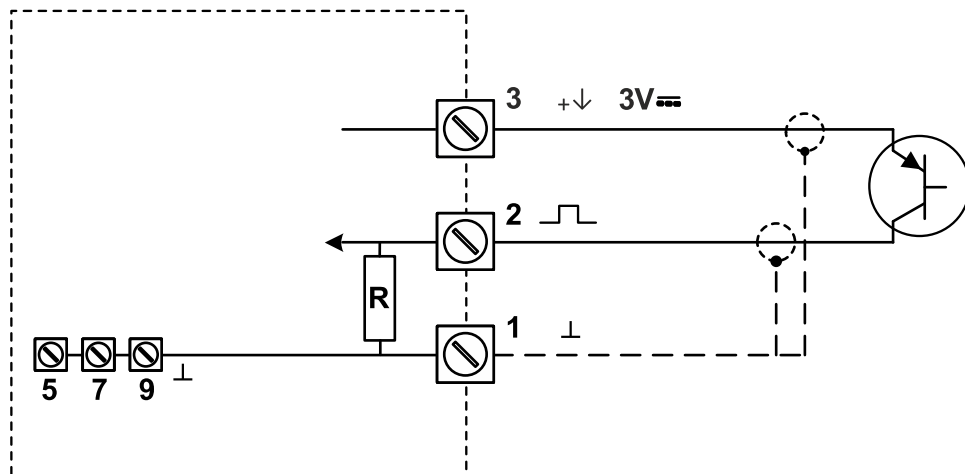

Fig. 14: Terminal connections – PNP signal input

Reed-switch

The B-BASIC is suitable for use with flowmeters which have a reed-switch. Make sure the contact resistance of the reed switch is less than 10k Ohm.

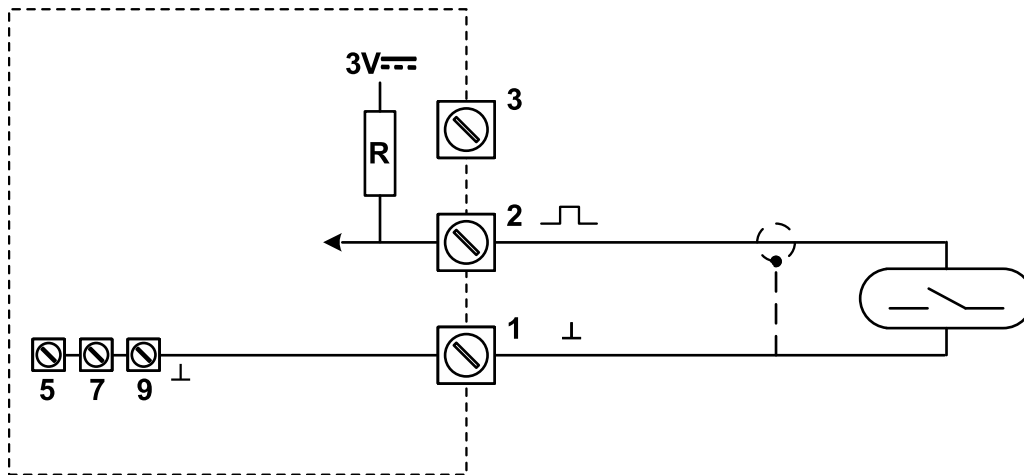

Fig. 15: Terminal connections – Reed-switch signal input

NAMUR-signal

The B-BASIC is suitable for flowmeters with a NAMUR signal. The standard B-BASIC is able to power the NAMUR sensor via the 8.2V sensor supply (terminal 4).

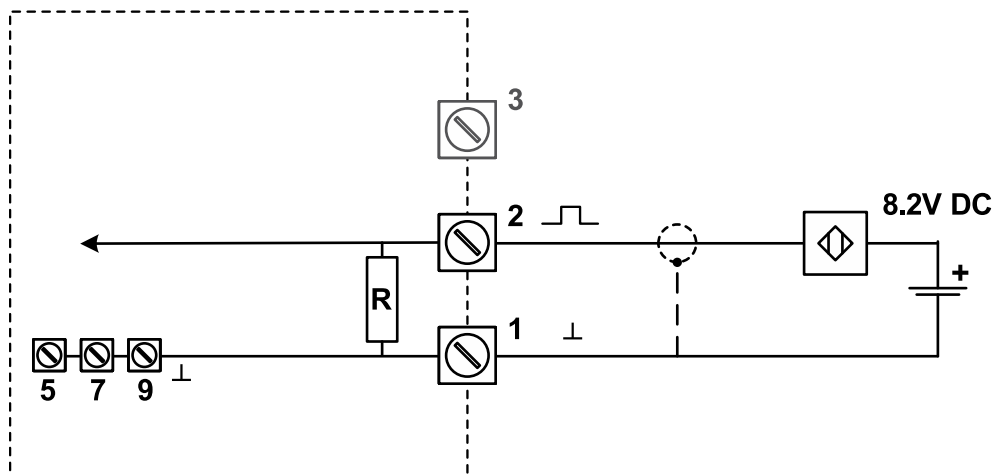

Fig. 16: Terminal connections – NAMUR signal input

4.7.2 TERMINAL 9-10: POWER SUPPLY

Connect an external power supply of 10-30VDC to these terminals. The maximum current is 15mA. When power is applied to these terminals, discharge of the internal battery is disabled and the backlight can be used.

4.7.3 SERVICE-PORT

The service port is available to configure the B-BASIC via an external device, e.g. a laptop. The port does not use the standard type connectors, but the connections are made with a special service port communications cable, which is available through your supplier or our website, as shown below.



The service port is not intended to be connected with a permanent connection.

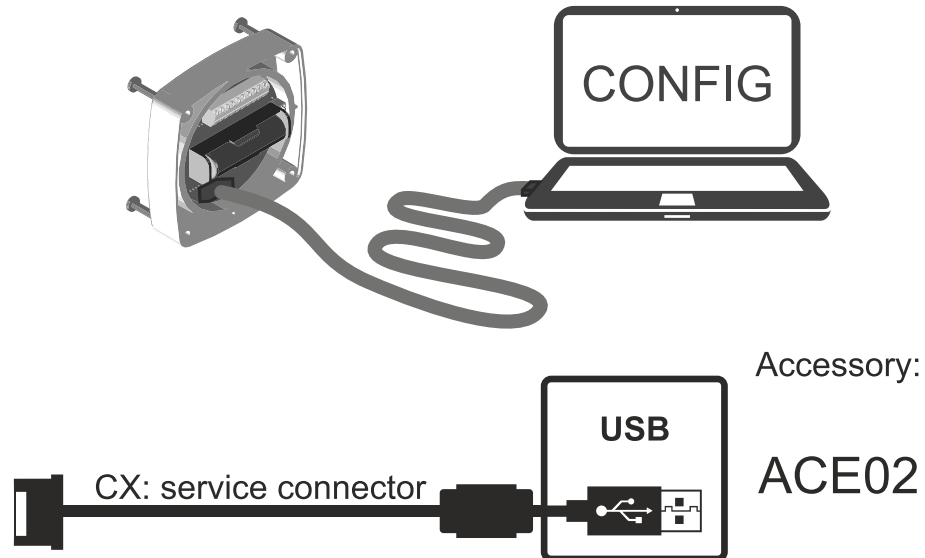

Fig. 17: Terminal connections – SERVICE-port

5 MAINTENANCE

5.1 GENERAL DIRECTIONS



- Mounting, electrical installation, start-up and maintenance of the instrument may only be carried out by trained personnel authorized by the operator of the facility. Personnel must read and understand this Operating Manual before carrying out its instructions. Take careful notice of the “Safety rules, instructions and precautionary measures” in the front of this manual.
- The B-BASIC may only be operated by personnel who are authorized and trained by the operator of the facility. All instructions in this manual are to be observed.
- Ensure that the measuring system is correctly wired up according to the wiring diagrams. The housing may only be opened by trained personnel.
- Take careful notice of the “Safety rules, instructions and precautionary measures” in the front of this manual.

The B-BASIC does not require special maintenance unless it is used in low-temperature applications or surroundings with high humidity (above 90% annual mean). It is the users responsibility to take all precautions to dehumidify the internal atmosphere of the B-BASIC in such a way that no condensation will occur, for example by placing dry silica-gel sachet in the casing just before closing it. Furthermore, it is required to replace or dry the silica gel periodically as advised by the silica gel supplier.

Battery life-time

The life-time of the battery is influenced by several issues:

- Pulse output.
- Low temperatures; the available power will be less due to battery chemistry.
- NPN and PNP inputs consume more energy than coil inputs.
- High input frequency.



Note !

It is strongly advised to use only necessary functions.

Check periodically

- The condition of the enclosure, cable glands and front panel.
- The input/output wiring for reliability and aging symptoms.
- The process accuracy. As a result of wear and tear, re-calibration of the flowmeter might be necessary. Do not forget to re-enter any subsequent K-factor alterations.
- The indication for low-battery. Replacement battery: see technical specifications.
- Clean the enclosure with a lint-free cloth, soaked with a mild soap solution or fresh water.

5.2 INSTRUCTIONS FOR REPAIR

This product cannot be repaired by the user and must be replaced with an equivalent certified product. Repairs are only allowed to be carried out by the manufacturer or his authorized agent.

Repair policy

If you have any problem with your product and you wish to have it repaired, please follow the procedure below:

- a. Obtain a Return Material Authorization (RMA) from your supplier or distributor. Together with the RMA, you need to complete a repair form to submit detailed information about the problem.
- b. Send the product, within 30 days, to the address provided with the RMA. The physical return of your repair can only take place after the authorization of your repair application, as confirmed by the RMA number.

If the product is within the warranty period and the reported problem falls under the warranty conditions, the product will be repaired or exchanged and returned within three weeks. Otherwise, you will receive a repair estimate.

5.3 BATTERY REPLACEMENT

5.3.1 SAFETY INSTRUCTIONS



- Handle the battery with care. A mistreated battery can become unsafe. Unsafe batteries can cause (serious) injury to persons.
- Mounting, electrical installation, start-up and maintenance of this device may only be carried out by trained persons authorized by the operator of the facility. Persons must read and understand this manual before carrying out its instructions.



The batteries are used to store electrical energy. The battery is a high-power battery which must be treated carefully. When the battery is mistreated or damaged, there is a risk of a fire, an explosion and serious burns.

1. Only use a battery which is applicable for the intended use.
2. Mind that you cannot switch off a battery.
3. Make sure, it is safe to work on the battery system.
4. Handle the battery with the utmost care to prevent a short circuit and damage.
5. Do not recharge, crush, disassemble, incinerate, heat above its rated temperature or expose the contents to water.
6. Dispose of the battery in accordance with the (inter)national, the manufacturer's and the plant owner's standards and regulations.

Change the battery:

- a) Obey the battery safety instruction.
- b) Open the B-Series, remove and keep the bolts (1).
- c) Hold the cover (2) and carefully remove the battery (3) from the battery holder (4). The holder can either be made of plastic (as indicated) or metal brackets.
- d) Inspect a plastic battery holder for signs of deterioration.
- e) Mind the polarity! Install a new battery (3) in the holder (4).
- f) Make sure, the display comes on.
- g) Install the cover (2) with the bolts (1).

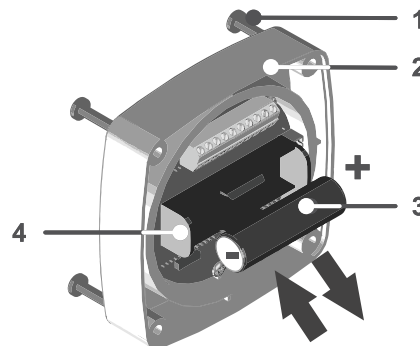

Battery specification

Primary, non-rechargeable, Lithium metal Thionyl Chloride (Li/SOCl₂), 1x3.6V/2.4Ah, AA size (IEC-R6, ANSI size15).

5.3.2 DISPOSAL OF BATTERIES



- Batteries pose an environmental hazard.
- Do not dispose of as general waste or incinerate.
- Return used batteries to a recycling point.

Appendix A. TECHNICAL SPECIFICATION

General

Display	
Type	High intensity numeric and alphanumeric LCD, UV-resistant, with bright backlight. <i>When only battery or loop powered, the backlight is not operational.</i>
Dimensions	54 x 29mm (2.13" x 1.14").
Digits	Seven 12mm (0.47") and eleven 7mm (0.28") digits. Various symbols and measuring units.
Refresh rate	During operation 8 times/sec, switches to 1 time/sec after 30 sec without operation.

Enclosures	
Material	GRP, UV-resistant and flame retardant.
Sealing	EPDM gasket.
Control keys	Two industrial micro-switch keys. UV-resistant Polyester keypad.
Rating	IP65, NEMA Type 4X
Dimensions	92 x 92 x 60mm (3.62" x 3.62" x 2.36") - W x H x D.
Weight	200 gram / 0.44 lbs.
Cable entries	Knock-out type. Side: 2x 16mm/0.63" Bottom: 1x 20mm/0.79" <i>Note: the rear-enclosure can be rotated in steps of 90°.</i>

Operating temperature	
Ambient	-20°C to +60°C (-4°F to +140°F).

Power requirements	
External power supply	10 - 30V DC. Max consumption: 15mA. <i>The power supply will also supply the backlight and the 8.2V DC sensor supply.</i>
Battery	Primary, non-rechargeable, Lithium metal Thionyl Chloride (Li/SOCI ₂), 1x3.6V/2.4Ah, AA size (IEC-R6, ANSI size15). Life-time depends upon settings and configuration - up to approx. 2 years. <i>Battery replacement: only with identical specification!</i>

Sensor excitation	
Standard	Terminal 3: 3V DC reference voltage for pulse signals, 1.2V DC for coil pick-up. Max. 100µA. <i>This is not a real sensor supply. Only suitable for sensors with a very low power consumption like coils (sine wave) and reed-switches.</i>

Terminal connections	
Type	Fixed terminal strip. Wire max. 1.5 mm ² .

Data protection	
Type	FRAM backup of all settings. Backup of running totals every minute. Data retention at least 10 years.
Password	Configuration settings can be password protected.

Directives and Standards	
EMC	EN 61000-6-2 BS 61000-6-2 EN 61000-6-3 BS 61000-6-3 EN 61326-1 BS 61326-1 FCC 47 CFR part 15
RoHS	EN 50581 BS EN 50581 EN IEC 63000 BS EN IEC 63000
IP & TYPE	EN 60529 NEMA 250

Input

Flowmeter	
Type P	Coil / sine wave 30mVpp, NPN, PNP, reed switch, NAMUR.
Frequency	Minimum 0Hz - maximum 6kHz for total and flow rate. Maximum frequency depends on signal type.
K-Factor	0.000001 - 9,999,999 with variable decimal position.

Operational

Operator functions	
Displayed information	<ul style="list-style-type: none"> • Flow rate • Total • Accumulated total
Functions	<ul style="list-style-type: none"> • Total can be reset to zero by pressing the CLEAR-key twice

Total	
Digits	7 digits.
Unit	L, m3, US gal, gal, bbl, kg, lb or none.
Decimals	0 - 1 - 2 or 3.
 Note !	<i>Total can be reset to zero.</i>

Accumulated total	
Digits	7 digits.
Unit / decimals	According to selection for total.
 Note !	<i>Accumulated total cannot be reset to zero.</i>

Flow rate	
Digits	7 digits.
Units	mL, L, m3, g, kg, ton, gal, bbl, lb, cf, none.
Decimals	0 - 1 - 2 or 3.
Time units	/sec - /min - /hr - /day.

Appendix B. PROBLEM SOLVING

In this appendix, several problems are included that can occur when the B-BASIC is going to be installed or while it is in operation.

Flowmeter does not generate pulses

Check:

- Signal selection SETUP 3.1.
- Pulse amplitude (paragraph 3.3.4).
- Flowmeter, wiring and connection of terminal connectors (paragraph 4.7.1).
- Power supply of flowmeter (paragraph 4.5.2).

Flowmeter generates "too many pulses"

Check:

- Settings for Total (SETUP 1) and Flowrate (SETUP 2).
- Type of signal selected with actual signal generated (paragraph 3.3.4),
- Sensitivity of coil input.
- Proper grounding of the B-BASIC, avoid ground loops.
- Use screened wire for flowmeter signals and connect screen to the sensor or ground input terminal of the flowmeter input.

Flowrate displays "0 / zero" while there is flow (total is counting)

Check:

- SETUP 2.2 / 2.4: are the K-factor and time unit correct?

The password is unknown

If the PIN cannot be retrieved, there is only one possibility left: call your supplier.

ALARM

When the alarm flag starts to blink an internal alarm condition has occurred. Press the SELECT-key several times to display the error code. The codes are:

0001 = display error
0002 = data-storage error
0004 = initialization error

When multiple alarms occur, the error code shown is the sum of the error codes as given above. E.g. 0005 is a combination of error code 0001 and 0004.

If the alarm occurs more often or stays active for a long time, please contact your supplier.

Appendix C. DECLARATION OF CONFORMITY

EU Declaration of Conformity

Fluidwell B–Series indicators

Veghel, February 2022

We, Fluidwell BV, declare under our sole responsibility that the B–Series indicators are designed and will operate conform the following applicable European Directives and Harmonised Standards, when installed and operated according to the related manuals:

EMC Directive	2014/30/EU	EN 61000–6–2:2005; EN 61000–6–3: 2007 /A1:2011; EN 61326–1:2013
RoHS Directive	2011/65/EU (incl. current amendments)	EN 50581:2012 EN IEC 63000:2018

Last two digits of the year in which the CE marking was affixed: 16.

I. Meij, Manager Technology



Fluidwell BV – P.O.Box 6, 5460 AA, Veghel, The Netherlands – Voltaweg 23, 5466 AZ, Veghel, The Netherlands
Fluidwell BV is ISO9001 certified by DEKRA Certification BV, Meander 1051, 6825 MJ, Arnhem, The Netherlands.

UKCA Declaration of Conformity

Fluidwell B–Series indicators

Veghel, February 2022

We, Fluidwell BV, declare under our sole responsibility that the B–Series indicators are designed and will operate conform the following applicable UK Legislation and Standards, when installed and operated according to the related manuals:

Electromagnetic Compatibility Regulations 2016	BS 61000–6–2:2005; BS 61000–6–3: 2007 /A1:2011; BS 61326–1:2013
The Restriction of the Use of Certain Hazardous Substances in Electrical and Electronic Equipment Regulations 2012 (incl. current amendments)	BS EN 50581:2012 BS EN IEC 63000:2018

Last two digits of the year in which the UKCA marking was affixed: 22.

I. Meij, Manager Technology



Fluidwell BV – P.O.Box 6, 5460 AA, Veghel, The Netherlands – Voltaweg 23, 5466 AZ, Veghel, The Netherlands
Fluidwell BV is ISO9001 certified by DEKRA Certification BV, Meander 1051, 6825 MJ, Arnhem, The Netherlands.

INDEX OF THIS MANUAL

actual settings	32	main-function	8
alarm	7	maintenance	22
battery low	7	NAMUR-signal	20
battery replacement and disposal	23	NPN signal	19
clear total	7	operational	6, 22
coil-signal	18	operator level	6
Configuration	8	others	12
contents	4	PNP-signal	19
declaration of conformity	27	power supply	20, 21
disposal	2	problem solving	26
electrical installation and safety	17	reed-switch:	20
flowmeter		safety instructions	2
signal	12	SETUP-level	8
flowrate		technical specification	24
decimals	11	terminal connectors	18
display	7	total	
K-factor	11	accumulated	7
K-factor decimals	11	clear	7
measuring unit	11	decimals	11
time unit	11	display	7
functional description	5	K-factor	11
Installation general conditions	13	K-factor decimals	11
keys	6	unit	11

LIST OF FIGURES

Fig. 1: Typical application for the B-BASIC	5
Fig. 2: Control panel	6
Fig. 3: Example of display information during process	6
Fig. 4: Example of low-battery alarm.	7
Fig. 5: SETUP-menu matrix structure	8
Fig. 6: Example external label with general data.	14
Fig. 7: Example internal label with terminal information.	14
Fig. 8: Dimensions enclosure	15
Fig. 9: Installation – Wall mounted	16
Fig. 10: Installation – Sensor mounted	16
Fig. 11: Terminal connectors B-BASIC	18
Fig. 12: Terminal connections – Coil signal input	18
Fig. 13: Terminal connections – NPN signal input	19
Fig. 14: Terminal connections – PNP signal input	19
Fig. 15: Terminal connections – Reed-switch signal input	20
Fig. 16: Terminal connections – NAMUR signal input	20
Fig. 17: Terminal connections – SERVICE-port	21

Notes:

Notes:

Notes:

LIST OF CONFIGURATION SETTINGS

SETTING	DEFAULT	DATE:	DATE:
1	TOTAL	Enter your settings here	
1.1	UNIT	L	
1.2	DECIMALS	0	
1.3	K-FACTOR	0000001	
1.4	K-FACTOR DECIMALS	0	
2	RATE		
2.1	UNIT	L	
2.2	TIME	/min	
2.3	DECIMALS	0	
2.4	K-FACTOR	0000001	
2.5	K-FACTOR DECIMALS	0	
3	METER		
3.1	SIGNAL	coil	
4	OTHERS		
4.1	MODEL	BASIC21	
4.2	SOFTWARE VERSION	03:06: _ _	
4.3	SERIAL NO	_ _ _ _ _	
4.4	PIN	0000	
4.5	BACKLIGHT	off	